



# **ZIGBEE Wireless Transformer Monitoring, Protection and Control System**

Ravishankar Tularam Zanzad, Prof. Nikita Umare , Prof. Gajanan Patle

M. E. Student, Dept. of CSE, AGPCE, Nagpur University, India

Professor, Dept. of CSE, AGPCE, Nagpur University, India

Professor, Dept. of CSE, AGPCE, Nagpur University, India

**ABSTRACT:** In normal ways all the Industrial or Electrical machineries are controlled by the manual operation. Hence there is step by step progress but most of the time there is not actually instant co-operation between system and operator in case of emergency or fault type situation .Therefore we are designing a system where there exists communication between system and operator. For this we are using Transformer, microcontroller, analog to digital converter.. As we know Distribution transformer is a major component of power system and its correct functioning is vital to system operations. To reduce the risk of unexpected failure and the ensuing unscheduled outage, on-line monitoring has become the common practice to assess continuously the condition of the transformer with. This paper presents design and implementation of a system to monitor and record key operation of a distribution transformer like overvoltage, over current, temperatures, rise or fall of oil level. which based on Wireless protocol. Sensors, including a Temperature Detector and a Liquid level sensor performs according to manufacturers' specifications are calibrated and tested By power distribution monitoring offices. The system is installed at the distribution transformer site and by measuring above parameters it will help the utilities to optimally utilize transformers and identify problems before any catastrophic failure.

**KEYWORDS:** Distribution transformer, Wireless protocol.

## **I. INTRODUCTION**

On line Wireless monitoring and diagnostic of power transformers has attracted considerable attention for many years. The main objectives are to prevent forced outages, indicate acceptable overload, assess the remaining insulation-life and reduce maintenance costs. To achieve these goals, the monitoring system manufacturers must follow strategies, which are in line with the interests of transformer owners. Transformer is the key equipment in power system, to ensure its safe and stable operation is important. Transformers either raise a voltage to decrease losses, or decreases voltage to a safe level. "Monitoring" is here defined as on-line collection of data and includes sensor development, measurement techniques for on-line applications. It is very difficult and expensive to construct the communication wires to monitor and control each distribution transformer station. Here ZigBee is used for communicating the monitored parameters. The failures of transformers in service are broadly due to: Over Load condition temperature rise, low oil levels, over load, Earth grounding , and improper installation and maintenance. Out of these factors temperature rise, low oil levels and over load, need continuous monitoring to save transformer life. A distributed transformer networks remote monitoring system increases the reliability of distribution network, by monitoring critical information such as oil temperature, and oil level of transformer. Data are collected continuously. Monitoring the transformers for problems before they occur can prevent faults that are costly to fix and result in a loss of service life.

## **II. BACKGROUND AND LITERATURE SURVEY**

1. Most power companies use Supervisory Control and Data Acquisition (SCADA) system for online monitoring of power transformers but extending the SCADA system for online monitoring of distribution transformers is an expensive proposition[1].



# International Journal of Innovative Research in Computer and Communication Engineering

(An ISO 3297: 2007 Certified Organization)

Vol. 4, Issue 2, February 2016

2. Distribution transformers are currently monitored manually where a person periodically visits a transformer site for maintenance and records parameter of importance. This type of monitoring cannot provide information about occasional overloads and overheating of transformer oil and windings. All these factors can significantly reduce transformer life. A number of techniques are currently being used for offline as well as online monitoring of power transformers[2].

3. In other conventional system, the protection relay equipment serves as a server, the PC in an office serves as a client, and the PC and relay equipment communicate by 1 to 1. We can perform and follows some personal computer in an office; download of the voltage and current data stored in the relay equipment when relay equipment is activated by some power failure; checking and changing the setting values of the protection relay; detecting an abnormal occurrence and the relay activation caused by power system faults. As an excellent information terminal which can acquire the real time data from a power system. It is important that the information in a relay can be easily accessed from an office and of which mechanism for performing the function described above is simple[3]. The PC and protection relay equipment are connected with the relations of 1 to 1, and while operating this system, it is necessary that the operator looks at the PC browser continually all the time. Moreover, in order to acquire information from a numbers of relay equipment, an operator must specify the address of each relay to access them in turn, which is complicated and time consuming. Furthermore, in this system, even when relays are connected within the same network, the relays cannot communicate and cooperate with each other. That is to say, relay equipment works only as a server providing data to PCs located in the remote office. Following fig shows such methods[4].

The Transformer Load Monitoring system (TLM) is a project aimed to reduce cost, increase efficiency and improve services to customers. The project was created by Metropolitan Electricity Authority (MEA) Thailand. The purpose was to build a monitoring system for medium voltage distribution transformers. These transformers have been installed on roadside electric poles around Bangkok. Transformers' data is significant to load management and research about transformers. An advanced distribution transformer load monitoring system is capable of measuring voltage, current and power[6].

### III. PROPOSED TECHNOLOGY

The proposed methodology is based on Robust technology meets safety reliability and fastest in operation. It consists of a sensing system, signal conditioning electronic circuit, controller. It is installed at the transformer site and the finding parameters recorded using the analog to digital converter of the embedded system. The acquired parameters are processed and recorded in the system memory. system will help the system to run under reliable condition and identify problems before any failure. For above result we are using a small step down transformer of 12 V, 1 Amps rating and small bulb are connected as a load. In this project we are using CT transformer for measuring load current. Also we are using Temp. Temperature Sensor for giving any rise of temperature, oil level sensor is also used which detects any fall of oil level. The values of voltage, current and temperature and level of oil of the transformer is directly applied to one of the input ports of the microcontroller. Along with this, a display is connected in the input port of the microcontroller value then the transformer will automatically shut down and in this way transformer life will be increased. We also designed Two-way communication here by which we can ask system about given parameter value just by sending Wireless Data to it so that we can have watch over transformer .For this it is not necessary for the operator to sit in the system premises which was the case at conventional system.

# International Journal of Innovative Research in Computer and Communication Engineering

(An ISO 3297: 2007 Certified Organization)

Vol. 4, Issue 2, February 2016

## A. BLOCK DIAGRAM

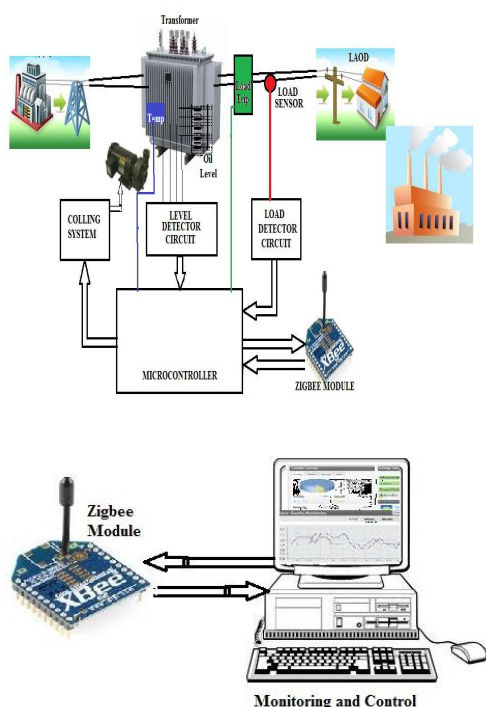

Figure1 Teraserver Diagram

## B. CIRCUIT DIAGRAM:

### a. Power supply

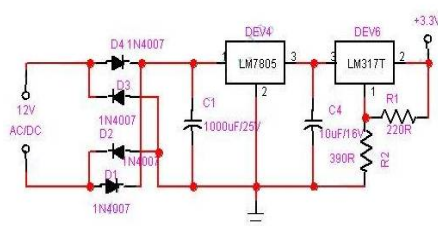

Figure 2. Supply Circuit

- b. Rectifier Circuit :** Rectifier is a circuit which converts the AC electrical energy into Dc electrical energy. For operating of semiconductor devices used in this project we need regulated DC supply. In this project we use centre tap full wave rectifier. Full wave rectifier circuit is capable of converting sinusoidal input into a unidirectional output. The circuit diagram is as shown in the figure.
- c. Filter Circuit :** It is seen that the output of the rectifier is not pure DC, because it contain some amount of AC component which is called as ripple factor which gives the fluctuation and hence to minimize the ripple in the

# International Journal of Innovative Research in Computer and Communication Engineering

(An ISO 3297: 2007 Certified Organization)

Vol. 4, Issue 2, February 2016

output the filter circuit is used. This circuit is connected after the rectifier circuit. In our project capacitor input filter is used. The circuit is as shown in the figure. The capacitor is connected in parallel to minimize the ripple factor.

- d. **Regulator Circuit :** In our project for the operation of IC we need +5 volt regulated supply is necessary therefore a voltage regulator circuit is used. A voltage regulator is a circuit that supplies constant voltages regardless of change in the load current. IC voltage regulators are versatile and generally used. The 78xx series consist of three terminal positive voltage regulators. These ICs are designed as fixed voltage regulator and adequate heat sink. It can be deliver output current in access of 1A. These devices do not required external component. These ICs has internal terminal overload protection and internal short circuit and current limiting protection.
- e. **Variable regulator IC LM317:** The LM317 is an adjustable 3–terminal positive voltage regulator capable of supplying in excess of 1.5 A over an output voltage range of 1.2 V to 37 V. This voltage regulator is exceptionally easy to use and requires only two external resistors to set the output voltage. Further, it employs internal current limiting, thermal shutdown and safe area compensation, making it essentially blow–out proof

## C. Main Circuit ATMEGA16

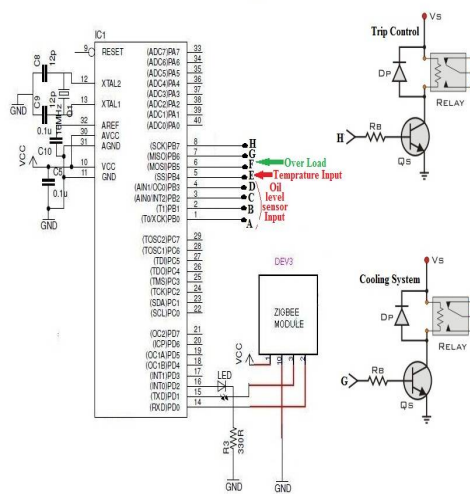

Figure 3. Interface Circuit

The ZIGBEE interface is another part of the transmitter section. The pin 3 (data in) of ZIGBEE module is connected to the USART transmission (TX-25) pin of port C in PIC. This wireless transmission follows USART protocols and is according to IEEE 802.15.4. ZIGBEE is a transceiver, in the transmitter section it is used as the transmitter. The receiver address of this ZIGBEE module is set as the address of the ZIGBEE module in the main server, so that data is send to this receiver only. It is a low power, low cost wireless mesh networking standard and it uses the ISM band for its transmission. The details of this interface are given in chapter5 (5.4). The Controller requires oscillator for clock generation, for this a crystal oscillator 16 MHZ is connected between pin 13 & 14. Parasitic capacitor of 33pf is used to increase the stability of the oscillator. In pin 1 of the PIC a switch is connected for resetting the registers. Pin 1 is the master clear. During normal operation its value is high, when the switch is pressed all the registers of the PIC is cleared. The supply to the PIC (5V) is given by the supply circuitry given in fig 4.1. The supply is given to pin 11 of the PIC. The supply to ZIGBEE module (3.3V) is given by LM317, which is given to pin 1 of ZIGBEE.

## D. TRANSISTORS RELAY LOAD CONTROL AND COOLING SYSTEM CONTROL

Then the transistor operates as a "single-pole single-throw" (SPST) solid state switch. With a zero signal applied to the Base of the transistor it turns "OFF" acting like an open switch and zero collector current flows. With a positive signal

# International Journal of Innovative Research in Computer and Communication Engineering

(An ISO 3297: 2007 Certified Organization)

Vol. 4, Issue 2, February 2016

applied to the Base of the transistor it turns "ON" acting like a closed switch and maximum circuit current flows through the device.

An example of an NPN Transistor as a switch being used to operate a relay is given below. With inductive loads such as relays or solenoids a flywheel diode is placed across the load to dissipate the back EMF generated by the inductive load when the transistor switches "OFF" and so protect the transistor from damage. If the load is of a very high current or voltage nature, such as motors, heaters etc, then the load current can be controlled via a suitable relay as shown.

## a. Oil Level Circuit

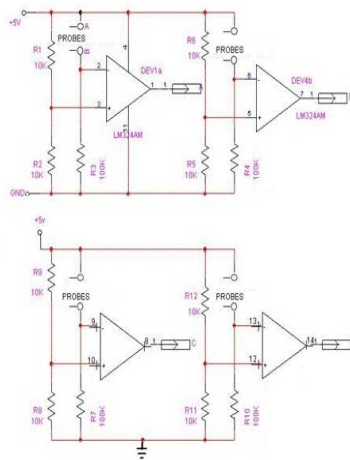

Figure 4. Level Sensor

The circuit comprises sensor parts built using op-amp IC LM324. Op-amps are configured here as a comparator. There sensitivity can be changed with the help of variable resistor. Level sensor wires are inserted in the Transformer to sense the Oil level of the transformer. The voltage from the copper plats are feed to comarator operational amplifier LM324 to compare with know voltage, then as result we get logic output either false (logic zero "0" 'ov) or true (logic one "1" or 5v) depending upon the copper sensing voltages from level sensing apparatus.

Output form LM324 is fed to microcontroller to transmit data over receiver section via zigbee module. The aim is to design an ambient temperature measurement circuit. The motivation for doing this Circuit is the fact that temperature measurement of Transformer has become an integral part of any control system operating in a temperature sensitive environment and the various learning outcomes associated during the implementation of the project.

In this project the ambient temperature will be displayed on. An Microcontroller will be used for handling all the required computations and control. In following we have briefly discussed details of a Microcontroller and the project in general. A temperature sensor DS 1820 is used for sensing the ambient temperature. The system will get the temperature from the IC and it will display the temperature over the seven segment display and this temperature was compared with the value stored by the user and if the Transformer temperature goes beyond the Preset temperature then Coolant system will on and if temperature goes below to a fixed value then Coolant system will OFF.

# International Journal of Innovative Research in Computer and Communication Engineering

(An ISO 3297: 2007 Certified Organization)

Vol. 4, Issue 2, February 2016

## E. PC Interfacing Circuit Receiver section

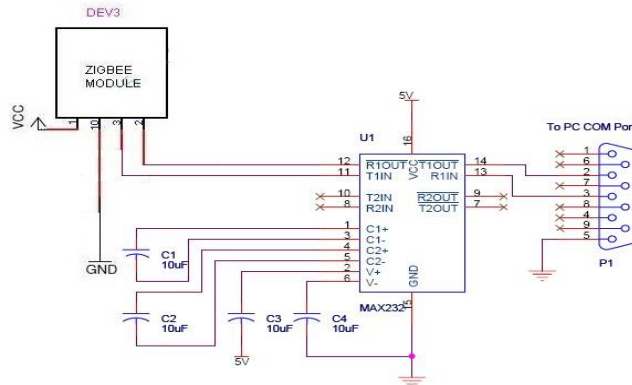

Figure 5. Pc Interfacing circuit

In the receiver section the ZIGBEE module can be used as receiver. This module receives the data send by the transmitters. The supply to the ZIGBEE module (3.3V) is given by the supply circuitry in fig with LM317.

To interface with the computer we have to convert the TTL logic into RS232 logic, for this purpose we use the IC MAX232. MAX232 is a dual driver/receiver that includes a capacitive voltage generator. The drivers ( $T_1$  &  $T_2$ ), also called transmitters, convert the TTL/CMOS logic input level into RS232 level. The transmitter (pin 10- $T_2$  in) take input from ZIGBEE's data out pin (pin 2 of ZIGBEE) and send the output to RS232's receiver at pin 7 ( $T_2$  out) of MAX232. We use four capacitors, two for doubling the voltage and other two for inverting the voltage. The capacitors are connected between pin 1 and pin 3, pin 4 and pin5, pin 2 and VCC, and pin 6 and GND. The transmitter output ( $T_2$  out) from MAX232 (RS232 logic) is connected to pin 2 (receive data) of RS232 port. Thus the data received are given to PC. The pin 5 of RS232 port is connected to ground.

## IV. RESULT

### A. Inspection & Testing of Transformer Oil:

The tenderer shall make arrangements for testing of transformer oil to be used in the transformers and testing will be done in presence of purchaser's representative. To ascertain the quality of transformer oil, original manufacturer's test report should be furnished to EE (Testing) at the time of factory inspection for acceptance of the lot. 10 % of the transformers offered will be tested for all tests without opening the transformer. Heat Run Test will have to be carried out on the transformer having maximum no load and full load losses taken together. C.E. (Distribution) will depute his representative at the time of final inspection along with CPA's representative.

### B. Power ON / OFF:

The meter shall be capable to record power ON/OFF events in the meter memory. All potential failure should record as power off event. The meter shall keep records for the minimum 280 events. (Occurrence + Restoration). For above abnormal conditions the recording of events shall be on FIFO basis. It shall be possible to retrieve the abnormal event data along with all related snap shots data through the meter optical port with the help of CMRI & downloaded the same to the base computer. All the information shall be made available in simple & easy to understand format.





# International Journal of Innovative Research in Computer and Communication Engineering

(An ISO 3297: 2007 Certified Organization)

Vol. 4, Issue 2, February 2016

## V.CONCLUSION

With modern technology it is possible to monitor a large number of parameters of distributed transformer at a relatively high cost. The challenge is to balance the functions of the monitoring system and its cost and reliability. In order to get effective transformer monitoring system to a moderate cost, it is necessary to focus on a few key parameters. WDTMS is able to record and send abnormal parameters of a transformer to concerned office. It works on Wireless technology.

## REFERENCES

- [1] C.E.Lin, M.Ling, and C.L.Huang (1993). "An expert system for transformer fault diagnosis using dissolved gas analysis". IEEE Transactions on Power Delivery Vol 8, No 1 January 1993
- [2] C. Bengtsson, "Status and Trends in Transformer Monitoring" IEEE Transactions on Power Delivery, Vol. 11, No. 3, July 1996.
- [3] Abdul-Rahman AI-Ali, et al., "GSM-Based Distribution Transformer Monitoring System" IEEE MELECON 2004, May 12-15, 2004, Dubrovnik, Croatia.
- [4] Li Cai and Nina Dai 'The Home Security System Based on ZigBee Technology' IEEE Transactions 2010.
- [5] The ZigBee Protocol [OB/EL], <http://www.digi.com/technology/rfarticles/wireless-zigbee.jsp> 2009.
- [6] Digi International Inc,XBee ZNet2.5/XBee-PRO ZNet2.5 OEM RF Modules, Product Manual v1.x.4x - ZigBee Protocol For OEM RF Module Part Numbers: XB24-BxIT-00x,Digi International , Inc.11001 Bren Road East Minnetonka, MN 55343877, 912-3444 or 952 912-3444 <http://www.digi.com>
- [7] V. Mayalarp, N. Limpaswadpaisarn, T. Poombansao, and S. Kittipiyakul, "Wireless mesh networking with XBee," in 2nd ECTI-Conference on Application Research and Development (ECTI-CARD 2010), Pattaya, Chonburi, Thailand, 10-12 May 2010.
- [8] Liebfried, T., "Online Monitors Keep Transformers in Service", IEEE Computer Applications in Power, July 1998. p.36-42.
- [9] CIGRE WG A2-27 "Recommendations for condition monitoring and condition assessment for transformers", 2007.
- [10] IEEE PC57.143 TM/D20, "Draft Guide for Application of Monitoring Liquid Immersed Transformers and their Components", March 2008.
- [11] Sokolov, V., Roizman, O., "Moisture Management in Power Transformers", CIGRE Transformer Committee A2 WG12-30, WG Presentation, 2006.
- [12] Ravishankar T. Zanzad "Review of Supervisory Model for Predictive Transformer Protection And Maintenance Using Wireless Sensor Network", International Journal of Scientific Engineering and Applied Science (IJSEAS) - Volume-1, Issue-7, October 2015 ISSN: 2395-3470 [www.ijseas.com](http://www.ijseas.com)

## BIOGRAPHY



**Ravishankar Tularam Zanzad** is a student of M.E. (Wireless Communication and Computing), Abha Gaikward Patil College of Engineering Nagpur,MS, India. He research interests are Computer Networks (wireless Networks), Computer Hardware parts repairing and Maintenance etc.