



# International Journal of Innovative Research in Computer and Communication Engineering

(An ISO 3297: 2007 Certified Organization)

Website: [www.ijircce.com](http://www.ijircce.com)

Vol. 4, Issue 12, December 2016

## Low Cost Portable E-Braille Device for Blind and Visually Impaired Persons

Swati Malik, Preet Jain

M.E. Student, Department of Electronics and Communication Engineering, Shri Vaishnav Institute of Technology and Science, Indore, M.P, India

Assistant Professor, Department of Electronics and Communication Engineering, Shri Vaishnav Institute of Technology and Science, Indore, M.P, India

**ABSTRACT:** Braille is vital for communication and education purposes for blind and visually challenged persons. Normal persons cannot face too many difficulties in their daily life or in the field of education while blind people or visually impaired persons alone can find a way to share their thoughts and feeling with others and understand them. In order to overcome the above said challenges our idea is to design a low cost portable device called “E Braille reader for visually challenged person”. The project has been designed keeping in mind the use of E-Braille reader for blind persons. A blind person will be able to read E-Books by actually connecting his hardware to certain E-Books. The matter from the E-Book is downloaded to his hardware. The matter is then spoken out by the hardware (the blind person can plug headphones) and also, the hardware rotates a disc that has the Braille characters embossed on a disc. The blind person can then feel the Braille from this disc surface.

**KEYWORDS:** STM32f407 ARM cortex M4 , WIFI module, servo motor, IR sensor

### I. INTRODUCTION

Globally, it is estimated that there are around 37 million people are totally blind, and over 15 million are from India. Some have low vision and some people have occurred some kind of visual impairment. As indicated by (WHO) it is evaluated that more than seven million individuals get to be visually impaired each year. 75% of visual deficiency is avoidable. 80% of visual impairment is avoidable. 90% of people with visual impairment live in developing countries. Most of the people with visual impairment are older and female are more at risks at every age, in every part of the world [1]. Blindness is the condition of lacking visual perception. The blind and visually impaired persons have many problems in their daily life and many activities are greatly restricted by loss of eyesight. There are many technologies which have been designed for them, so that they can easily communicate with other persons. Many efforts have been made to improve their daily life difficulties by the use of technology. Our idea is to make low cost portable e-Braille reader with great accuracy of reading Braille characters. In this project we proposed a system that enables blind or visually impaired people to sense the Braille character easily through Braille reader device.

The fundamental point of this work is to give the visually impaired persons to sense the Braille character with e-Braille per user and afterward Braille character are changed over into voice. Blind persons likewise have issue like they can't see words or character. Accordingly in this work we proposed a framework through which they can without much of a stretch sense Braille characters and after that this Braille characters are changed over into sound so that visually impaired persons can listen the characters.

### II. RELATED WORK

In the course of the most recent decades, research has been directed for new gadgets to outline a decent and solid; framework for visually impaired or outwardly debilitated persons to speak with different persons. There are some framework which has some detriments. The TIIC IDC 2015 team created a device with the functionality of sensing the Braille characters with e-Braille reader device. This Braille characters corresponds to characters which the blind person

# International Journal of Innovative Research in Computer and Communication Engineering

(An ISO 3297: 2007 Certified Organization)

Website: [www.ijirccce.com](http://www.ijirccce.com)

Vol. 4, Issue 12, December 2016

has to read. E-Braille reader consists of Bluetooth module, SD card module, voltage regulator. Main purpose of providing Bluetooth is to read the e-book files from another Bluetooth device like android and laptops. The whole set up is based on servo motor. Disc is mounted over servo motor via gears. This system has disadvantage that blind person can't listen the Braille characters which they sense. The paper proposes idea of Braille display. In this study another Refreshable Braille Display was created to help outwardly debilitated people take in the Braille letters in order simpler. By method for this framework, any content downloaded on a PC can be perused by the outwardly debilitated individual right then and there by feeling it by his/her hands. Through this electronic gadget, it was expected to make taking in the Braille letters in order less demanding for outwardly debilitated people with whom the essential tests were conduct.[2]The 'portable Refreshable E-Braille' were designed for blind and visually impaired. This device helps the blind or visually impaired persons to read eBooks that are stored in micro SD cards, read SMS from mobile phone over Bluetooth module and display them as Braille characters which they can easily recognize. But this device has disadvantage that the user can't get the audio input of Braille character which are displayed. This would be easier for blind and visually impaired to handle the device with ease. [3] Idea of a device for communication between people: blind, deaf, deaf blind and unimpaired device were designed for the communication between blind and unimpaired persons [4]. By presenting an updated minimal effort material interface called the Smart Slate that will supplement classroom instruction and serve as a halfway substitute. The 'Smart Slate' will support landscape and geographic projections, reiterative learning forms and educational games to authorize successful learning [5].

### III. PROBLEM STATEMENT

The current technology used in Braille system is far from optimal due to high cost and portability. The traditional typewriter and printers for Braille are very expensive and bulky. A person who cannot read faces various difficulties in the workplaces, in schools and in communities. Literacy is more important now than it has been at any other stages in the past. People who are blind and visually impaired cannot effectively read or scan through textual information with Braille refreshable display. The consequences of this inability to access Braille are becoming more and more damaging to their ability to succeed in their communities.

### IV. PROPOSED SYSTEM

The block diagram of proposed system is shown below

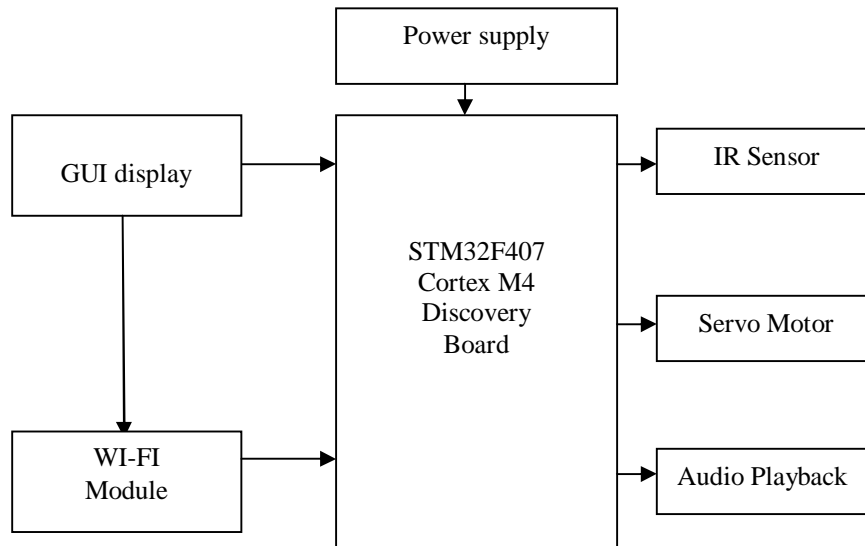

Figure 1 Block Diagram of System

The proposed system aims to implement a device for blind users which helps them to read E-books by connecting the hardware with certain E-books. This system is capable of reading Braille characters fastly. The sentences from the E-Book are downloaded to the system hardware. Those sentences are then spoken out by the audio system present on the system hardware. The blind person can plug headphones to hear these E-books. Also, in the hardware a rotating disc is provided on which the Braille characters are embossed. The blind person can touch and sense the Braille characters on the disc surface. In this system Braille E-reader device consist of WIFI module, ARM cortex controller, servo motor. Main purpose of providing WIFI is to receive e-book or communicate with one another device like android or laptops wirelessly within a particular area. This data is converted into serial data and then send to microcontroller. Microcontroller writes this data using SPI into the internal RAM in the form of text files. This text sends to

# International Journal of Innovative Research in Computer and Communication Engineering

(An ISO 3297: 2007 Certified Organization)

Website: [www.ijircce.com](http://www.ijircce.com)

Vol. 4, Issue 12, December 2016

WI-FI and then it will write inside the internal memory. The motor will control according to character written in internal memory. Braille characters are then sense by the blind user and then it is converted into audio output which helps blind person to hear the characters through headphone. One more feature is added in this system for providing user to achieve fast accuracy on disc i.e. auto mode and manual mode. These two modes helps user to get the output frequently on disc. These two modes are described below:

**Auto mode** - In auto mode disc rotates and stops at particular character automatically and simultaneously audio is played as disc rotates to the character.

**Manual mode**- Manual mode works through finger detection mechanism. In manual mode disc rotates and stops only when the IR sensor senses the finger on it.

## V. PROCESS FLOW

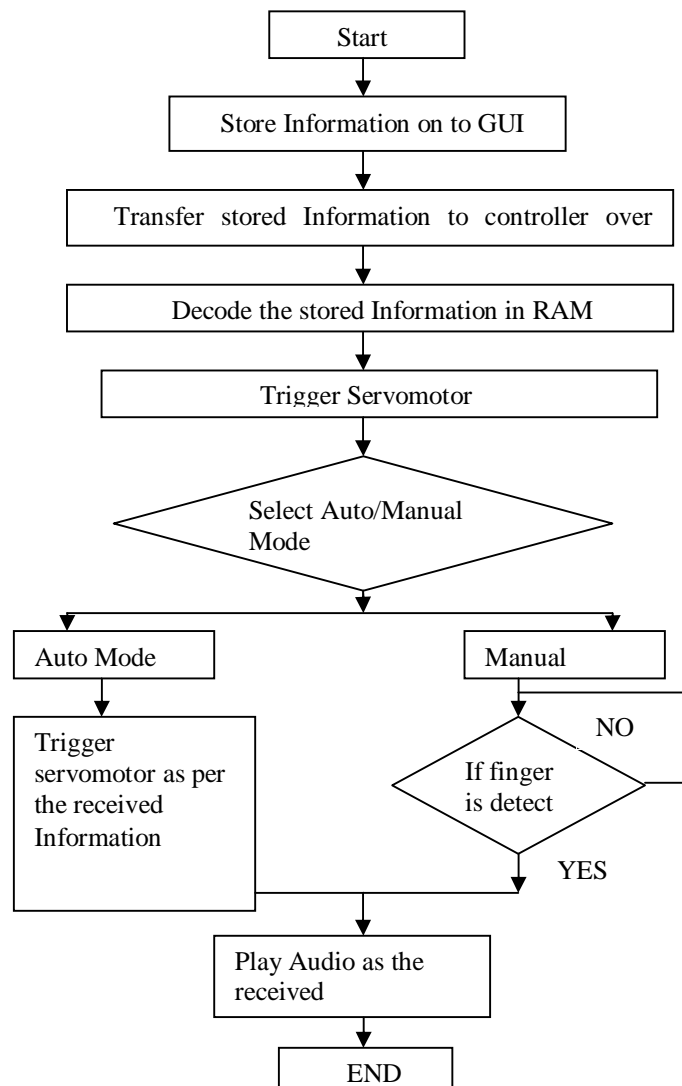

The steps followed for designing the system are:

- User stores information on GUI (laptop).
- Store information is sent to microcontroller over WI-FI



# International Journal of Innovative Research in Computer and Communication Engineering

(An ISO 3297: 2007 Certified Organization)

Website: [www.ijircce.com](http://www.ijircce.com)

Vol. 4, Issue 12, December 2016

- Information is stored in the internal RAM and then it is decoded
- Then controller starts moving decoded text through servo motor
- The system is divided into two modes i.e. auto and manual mode which is operated through a switch.
- In auto mode disc rotates and stops at particular character automatically.
- In manual mode disc rotates and stops only when IR sensor senses finger.
- Audio is played simultaneously as disc rotates to character
- The data is then displayed.

## VI. HARDWARE DESCRIPTION

This device system consists of following major components such as:

1. **STM32F407:** STM32f4 comes in various series. In this system STM32F4 ARM microcontroller is use. Stm32f407 includes everything on system on chip (soc) required for user functionality. It includes on board ST-LINK/V2 –A embedded debugging tool, two ST MEMS digital accelerometer, a digital microphone, one audio DAC with integrated class D speaker. This audio DAC functionality of the controller is used in this project to get the audio output. It includes eight LEDs, two push button (user and Reset). It includes extension header for quick connection prototyping. It includes 1-Mbyte Flash memory, 192-Kbyte RAM in an LQFP100 package.
2. **WI-FI Module:** In this project (rather than project you can use work or system) ESP8266 Wi-Fi module is used which is to used to receive e-book files or communicate with one another device like android or laptops wirelessly within a particular area. Every module comes pre-modified with an AT commands used for activate the Wi-Fi module. It is system on chip (soc) with capabilities for 2.4 GHZ WI-FI (802.11b/g/n, supporting WPA/WPA2.It has 64kb boot ROM, 1MB of flash.
3. **Servo Motor:** Servos are controlled by sending an electrical beat of variable width, or pulse width modulation (PWM), through the control wire.. A servo engine can normally just turn 90 degrees in either heading for a sum of 180 degree development. In our project, it is used for positioning and rotating .the Braille characters that are embossed on disc. It has much specification such as high response, high efficiency, high precision positioning, smooth and fast rotation and accurate angle rotation.
4. **IR Sensor:** An IR sensor is used in our project for finger detection mechanism

## VII. RESULTS

The framework, which we are creating, is in requirement for visually impaired, blind individual which is able to read E-books through Braille dialect. In figure 2 auto mode is shown. In this text 'SWATI' is written E Braille GUI software. This GUI software sends typed text on WIFI to controller and then controller reads the text and decodes the characters.

# International Journal of Innovative Research in Computer and Communication Engineering

(An ISO 3297: 2007 Certified Organization)

Website: [www.ijircce.com](http://www.ijircce.com)

Vol. 4, Issue 12, December 2016

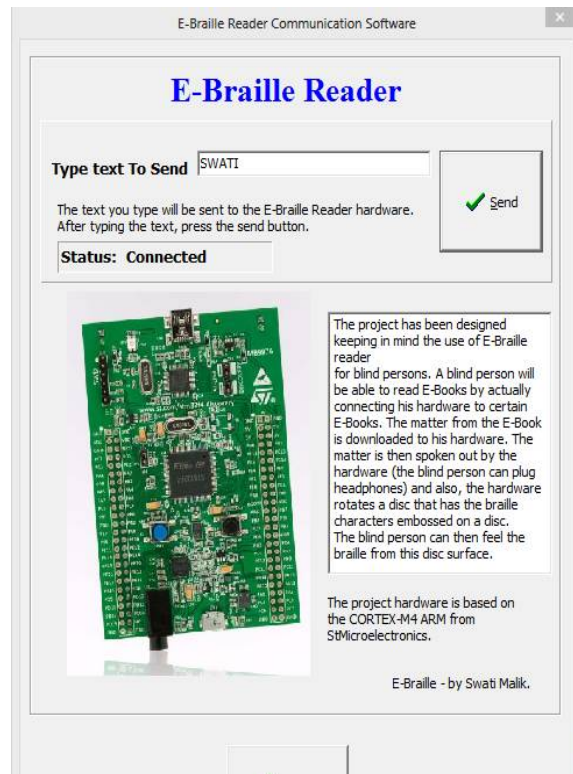

Figure 2 GUI display in Auto Mode

In figure 3 decoded texts 'SWATI' is displayed and spoken out by the hardware.

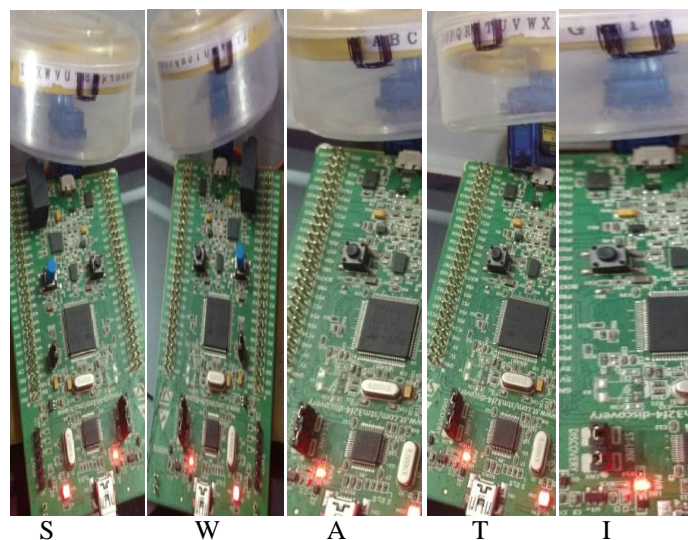

Figure 3 Image shows the result of text 'SWATI'

In figure 4 manual mode is shown. In this the text 'SKY' is written in GUI display and then it is send on WI-FI to controller and then decodes the characters.

# International Journal of Innovative Research in Computer and Communication Engineering

(An ISO 3297: 2007 Certified Organization)

Website: [www.ijircce.com](http://www.ijircce.com)

Vol. 4, Issue 12, December 2016

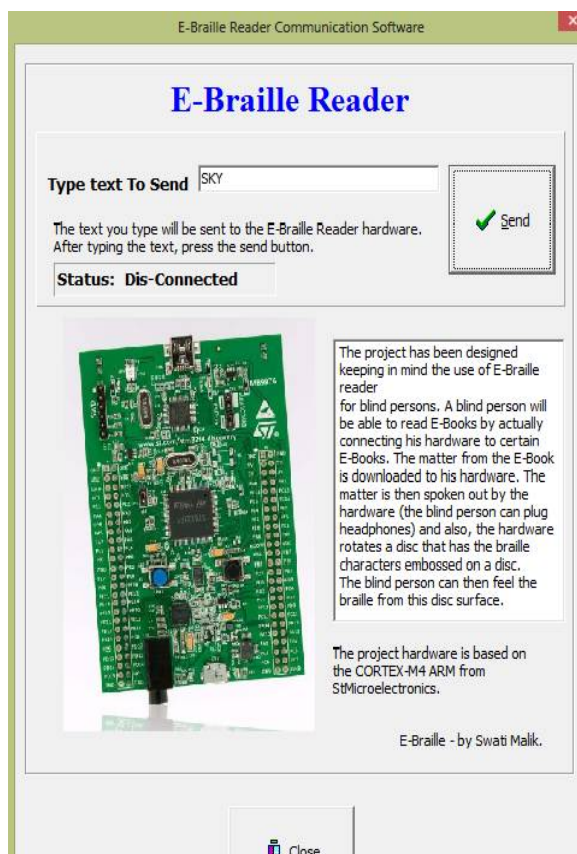

Figure 4 GUI display in Manual mode

Figure 5 the decoded text of 'SKY' is displayed and spoken out by hardware

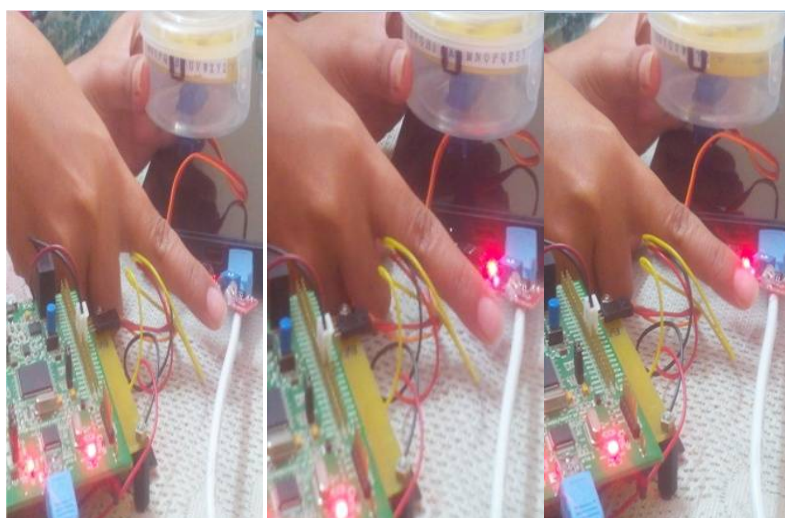

Figure 5 Image shows the result of text 'S K Y'



# International Journal of Innovative Research in Computer and Communication Engineering

(An ISO 3297: 2007 Certified Organization)

Website: [www.ijircce.com](http://www.ijircce.com)

Vol. 4, Issue 12, December 2016

## VIII. CONCLUSION

The paper details the working of a Braille device for blind and visually impaired persons which help them to read and hear E Books. The device helps them in different conduct like correspondence with typical persons, in going, in their education. Primary point of preference of this gadget is that it is ease and compact. The WI-FI technology used in the proposed system is to provide wide range than using Bluetooth technology. The use of two modes i.e. auto and manual mode provides user to achieve fast result on display. The servo motor use in the system is for faster response of rotation of characters. The advantage of using servo motor in this system is that the step angle is programmable. Thus the proposed system provides a low cost Braille device for the education of blinds.

## REFERENCES

1. World health organization sheet “visual impairment and blindness: world health organization august[ 2014]
2. Ayşe Eldem, Fatih Başçiftçi “Electronic and Computer-Assisted Refreshable Braille Display” Developed for Visually Impaired Individuals “in International Scholarly and Scientific Research & Innovation.
3. M.A. RAJA, Arunya, Dipti yadav, G. Kanitha, R. Maheshwari proposed “portable refreshable E- Braille” in International Journal of Engineering research and applications.
4. Fernando Ramirez-garibay, cesar Milan olivarria, Alejandro Federico Joel chuegel proposed ‘My Vox’- device for communication between people: blind, deaf, deaf blind and unimpaired. IEEE global Humanitarian technology conference
5. Raghavendra S H, Sreecharan Sankaranarayanan “smart slate”- providing elementary education to the blind in IEEE Canada International Humanitarian technology conference
6. M. Freddie Dias, Sarah Belousov, Ermine Teves, Bradley Hall, Imran Fanaswala, Anthony Velázquez, and M. Bernardine Dias “Accessible and Customizable Tools 1 to Motivate Braille Literacy.”
7. Ebnet, Matthew (2001), “Braille challenge gives young blind students a chance to shine
8. Ramiro Velazquez, Enrique Preza and Hermes Hernandez, „Making eBooks Accessible to blind Braille Readers”, in IEEE International workshop on Haptic Audio Visual Environments and their Applications, Ottawa, Canada, 2008, pp.25- 29.
9. Sunil Kumar M.E –Karnataka University Braille language learner for blinds International Journal Of infinite Innovations in technology 2012-2013
10. Nicolau, H., et al. UbiBraille: designing and evaluating a vibrotactile Braille-reading device. In *proc. of the ACM SIGACCESS conference on Computers & accessibility*. 2013