



Web Server Based Parameters Monitoring System for Green House

Sandip Khot¹, Dr. M. S. Gaikwad²

P.G. Student, Department of E & TC Engineering, Sinhgad Institute of Technology, Lonavala, Maharashtra, India¹

Principal, Department of E & TC Engineering, Sinhgad Institute of Technology, Lonavala, Maharashtra, India²

ABSTRACT: light intensity based most of the devices can be controlled. Most of the time to differentiate between day and night time, measuring light from sun light is essential. Where, light measurement and analysis is an important step in ensuring efficiency and safety. Plant growth in farming is purely dependent on the light intensity falling on the top of canopy. This paper introduces real time remote Light intensity monitoring system using Raspberry Pi which enables the user to track the lighting system in green house remotely for improving plant growth. The main feature of this system is instantaneous light intensity monitoring and data storage in the database on the cloud for future use in any internet enabled device. This facilitates experts to take right decisions at right time to obtain desired results in plant growth.

KEYWORDS: Green House, Light Intensity; Remote Monitoring; Raspberry Pi; Web server; Wi-Fi; Dynamic Charts.

I. INTRODUCTION

There are variety of applications for Light Meters for measuring and maintaining adequate light levels such as laboratories, hospitals, schools etc. [1]. To maintain healthier and safer environment adequate light levels in the work place are necessary. Irrespective of weather condition, the light intensity has to be sufficient for plant growth. Also during summer days, light intensity coming from sun light is too high which has to be controlled for avoiding over heating of the plants. This results in maintaining health of the plants.

The job of a greenhouse is to provide a structure for growing plants that is transparent to sunlight, yet sufficiently enclosed to reduce convective heat loss (the exchange of air between inside and outside). Some of the solar radiation travelling through the covering material produces heat, and some of it is used for plant photosynthesis, resulting in the production of useful biomass. The light environment inside a greenhouse structure is primarily determined by the amount of solar radiation received at the location as indicated in Figure 1. The introduction of electric lighting started the use of artificial light sources for plant irradiation. Artificial light sources (e.g., incandescent, fluorescent, and especially high intensity discharge lamps) can be used to supplement the (limited) amount of solar radiation received by a crop on darker days[2].

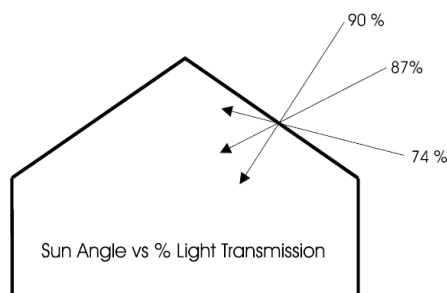

Fig.1:Solar Radiation Penetration in green house from ceiling

International Journal of Innovative Research in Computer and Communication Engineering

(An ISO 3297: 2007 Certified Organization)

Vol. 4, Issue 5, May 2016

II. LITERATURE SURVEY

A discussion on supplemental lighting is considered the effects of solar radiation on the light environment experienced by greenhouse crops in [3]. In addition it has indicated that, the greenhouse structure and a possible shading system will reduce the amount of solar radiation reaching the top of the plant canopy. The successful use of supplemental lighting for greenhouse plant production requires a careful design incorporating such elements as light intensity, light distribution and uniformity, cost of operation, and system maintenance. When measuring light for plant growth, it is important to use the correct unit of measurement, the appropriate type of sensor, and the desired placement of light sensors as indicated in [4]. Computer control of the greenhouse light environment usually involves both lighting and shading systems, but in some cases also includes carbon dioxide enrichment.

Once the solar radiation reaches the surface of the earth, the greenhouse structure is the next obstacle it has to pass through. Framing members and glazing bars are usually opaque and absorb or reflect all the light that falls on them. The same is true for the gutters. In addition, shade curtains, electric conduits, water lines, heating equipment and pipes, horizontal airflow fans, and supplemental lighting are installed near the top of the greenhouse, all of which block light from reaching the plants inside as in [5]. In some cases, evaporative cooling pads and ventilation fans are installed in the sidewalls, which further reduce the amount of solar radiation. All added up, a very significant amount of solar radiation available outside the greenhouse will never reach the plants inside (30% for newer, 50% and higher for older greenhouses) [6]. Especially during the darker months of the year when the solar elevation above the horizon is low and the days are short, the greenhouse structure and the various systems installed can block large amounts of light from reaching the plants. Finally, the choice of greenhouse cover (glass or plastic) will have an impact on the amount of light transmitted.

III. PROPOSED WORK

The proposed work consist of green house design considerations and electronic system development.

Green House Structure Consideration:

The green house structure consist of automatic light intensity based electronic system deployed inside it along with movable ceiling panels as indicated in Figure 1.

Light Intensity Measurement

For the sake of light intensity based ceiling diaphragm control, LDR based light intensity measurement circuit is developed. The circuit design is as indicated in Figure 2. The designed circuit using opamp IC TL072 is 3rd ordered low pass filter. The low pass filter is allowing to pass frequencies below 100Hz. The need of low pass filter is to avoid sudden flickering from light sources. The output of this circuit is sufficiently calibrated to be fed to ADC circuit consisting of MCP 3208. The calibration calculations are as indicated in equation 1 and 2. The relationship between light intensity LUX and Load resistance RL for LDR is given by,

$$RL = (500/LUX) \text{ KOhm} \dots \dots \dots (1)$$

Hence the output voltage of LDR when connected to 3.3V supply voltage via 3.3K resistor is given by,

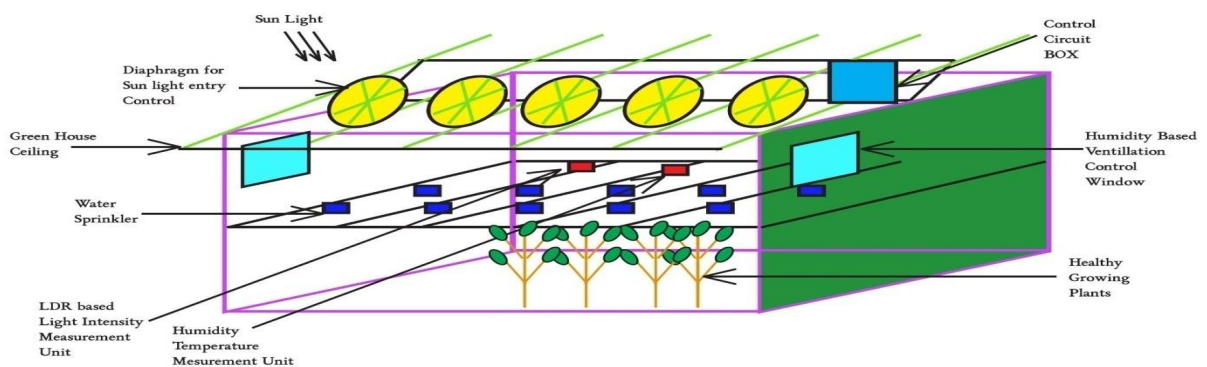

Fig.2 Proposed green house structure along with electronic system inside

International Journal of Innovative Research in Computer and Communication Engineering

(An ISO 3297: 2007 Certified Organization)

Vol. 4, Issue 5, May 2016

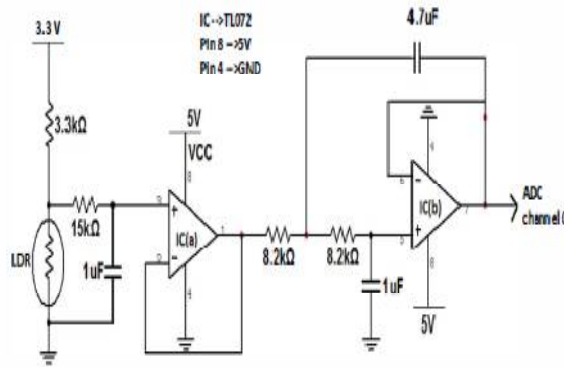

Fig.3: LDR based light intensity measurement circuit

$$V_0 = (3.3 * RL) / (RL + 3.3) \dots \dots \dots (2)$$

Hence LUX can be calculated by,

$$LUX = ((1650 / V_0) - 500) / 3.3 \dots \dots \dots (3)$$

Analog to Digital Converter (ADC)

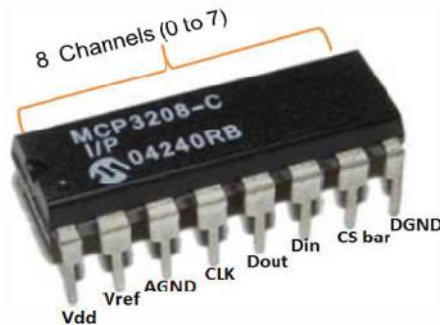

Fig.4: MCP 3208 ADC.

MCP 3208 is 12bit ADC which acts as bridge between Raspberry pi and analog circuit. SPI interface is possible from MCP 3208 to Raspberry pi GPIO header [8].

Raspberry Pi Board

Raspberry Pi (shown in Figure 5) is a credit-card-sized ARM powered Linux computer developed in the UK by Raspberry Pi foundation with the intention of stimulating the teaching of basic computer science in schools. It has five models; Model A has 256Mb RAM, one USB port and no network connection. Model B has 512Mb RAM, 2 USB ports and an Ethernet port [9].

International Journal of Innovative Research in Computer and Communication Engineering

(An ISO 3297: 2007 Certified Organization)

Vol. 4, Issue 5, May 2016

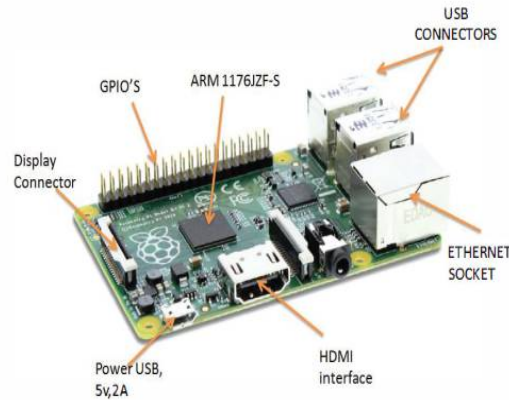

Fig.5: Raspberry Pi Board

e. WiFi Dongle

Wi-Fi is a popular wireless networking technology thus uses radio waves to provide wireless high-speed Internet and network connections. The Wi-Fi Alliance, the organization that owns the Wi-Fi registered trademark term specifically defines Wi-Fi as any "wireless local area network (WLAN) products that are based on the Institute of Electrical and Electronics Engineers' (IEEE) 802.11 standards.



Fig.6: WiFi Dongle

IV. SYSTEM DESIGN AND RESULTS

System Overview:

The total system designed for the proposed work is indicated as block diagram in the figure 7. The raspberry Pi board is connected to Humidity, Light measurement and control circuits. By gathering all data it uploads to Cloud based server from which the data is accessible to user via wireless internet connection to cloud from smart phone or tablet. We can store Acquire in the database, developed web application stored in the server. Client can access the system with IP address (represented in Fig.10) through computer or Smartphone or Tablet or any other internet enabled device.

International Journal of Innovative Research in Computer and Communication Engineering

(An ISO 3297: 2007 Certified Organization)

Vol. 4, Issue 5, May 2016

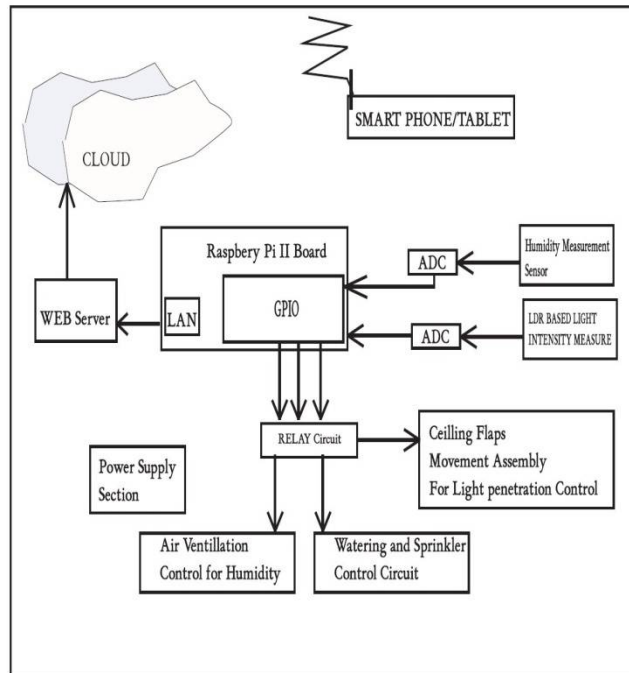

Fig.: System Design Block Diagram

Crop Considerations:

Table 1 Indicates the light intensity based irradianations considered for different crops along with supplementary light sources with required duration in hours.

TABLE I. CROP BASED IRRADIATION

Crops (Species)	Day Duration (Hours)	Irradiance (W/m ²)
Tomatoes	12-15	8-15
Cucumber	11-13	8-15
Peppers	12-15	8-15
Foliage Plants	3-6	8-15
Bedding plants	3-8	3-9
Roses	11-12	5-8

For proper plant growth the light intensity will be controlled according to the values indicated in table 1. The resulting growth is quite good compared to normal green houses. Table 2 indicates the resulting growth in plants height from the day of seeding as a effect of implemented system. The readings are taken after 1 month duration with proposer controlled environment as in proposed system.



International Journal of Innovative Research in Computer and Communication Engineering

(An ISO 3297: 2007 Certified Organization)

Vol. 4, Issue 5, May 2016

TABLE II. COMPARATIVE PLANT GROWTH ANALYSIS

Crops (Species)	Growth due to existing system (in cm)	Growth due to proposed system (in cm)
Tomatoes	11-14	15-18
Cucumber	8-11	12-13
Peppers	9-11	12-14
Foliage Plants	11-12	16-17
Bedding plants	3-4	6-8
Roses	12-13	15-18

V. CONCLUSION

The designed cloud based light intensity monitoring system for proper plant growth in green house has shown significantly improved results in plant growth. The results are satisfactory in terms of timely information gathering and timely monitoring the environment of the plant as per crop needs. The commercial farming can get benefited in terms of fast and healthy plant growth resulting in more profits. For the sake of future modifications in case of more enhancement, the data stored in cloud can be used as a platform for future plans and new strategies at any instant of time via smart terminals connected to internet.

REFERENCES

- [1] Tillmann De Graaf, Mennatalla Dessouky and Helmut F.O. Muller, "Sustainable lighting of museum buildings", Science Direct journal volume 67, July 2014, pp. 30-34.
- [2] Bezbradica M, Trpovski Z, "Advanced street light maintenance using GPS, light intensity measuring and incremental cost-effectiveness ratio", International conference on High Performance Computing and Simulation, 2014, pp. 670-675.
- [3] Nagaraju, C. H. Kireet, N. Pradeep Kumar and Ravi Kumar Jathoth, "Performance Comparison of Signal Conditioning Circuits For Light Intensity Measurement", World Academics Journal of Engineering Sciences, PP. 2007 (1-10), Vol. 01, Issue 02, 2014 (ISSN: 2348-635X)
- [4] W. Winchell, "Lighting For Poultry Housing" Agricultural Engineer, Canada Plan Service.
- [5] N.R.Mohanty and C.Y.Patil, "Wireless sensor and network design for greenhouse automation", International Journal of Engineering Technology, vol3, Issue2, August 2013.
- [6] Anjum Awasthi & S.R.N Reddy of IP university, India, Global journal of computer science and technology network "Monitoring for precision agriculture using WSN", web & security volume 13 issue 7 version 1.0 Year 2013.
- [7] HoSeong Cho, DaeHeon Park, Chul-Young Park, Hong-Geun Kim, Chang-Sun Shin, Yong-Yun Cho, and Jang-Woo Park "A study on localization based Zigbee and Monitoring system in Greenhouse environment" Proceedings of IEEE 3rd International Conference on Data Mining and Intelligent Information Technology Applications PP190-195 oct 2011.
- [8] ww1.microchip.com/downloads/en/DeviceDoc/2198c.pdf
- [9] Raspberry pi community, "http://www.raspberrypi.org/products/model-b-plus-f."
- [10]