



IJIRCCCE

e-ISSN: 2320-9801 | p-ISSN: 2320-9798



INTERNATIONAL JOURNAL OF INNOVATIVE RESEARCH

IN COMPUTER & COMMUNICATION ENGINEERING

Volume 10, Issue 6, June 2022

ISSN INTERNATIONAL
STANDARD
SERIAL
NUMBER
INDIA

Impact Factor: 8.165



9940 572 462



6381 907 438



ijircce@gmail.com



www.ijircce.com

Smart Jacket for Industrial Employees

M.Suneel¹, M.V.V.E.Rishitha², M.Yaswanthi³, Ch.Ganesh⁴, A.Sai Tarun⁵

Associate Professor, Department of ECE, Sri Vasavi Institute of Engineering & Technology, Nandamuru, A.P, India ¹

U.G. Student, Department of ECE, Sri Vasavi Institute of Engineering & Technology, Nandamuru, A.P, India ²

U.G. Student, Department of ECE, Sri Vasavi Institute of Engineering & Technology, Nandamuru, A.P, India ³

U.G. Student, Department of ECE, Sri Vasavi Institute of Engineering & Technology, Nandamuru, A.P, India ⁴

U.G. Student, Department of ECE, Sri Vasavi Institute of Engineering & Technology, Nandamuru, A.P, India ⁵

ABSTRACT: The climatic conditions are varying from time to time effecting the environment. Extreme hot or extreme cold are very dangerous to the health. Excessive exposure to heat as well as keeping the body too cold causes serious health issues. In extremely hot environment, the most serious problem is heart stroke. At very cold temperature, the most serious problem is the risk of hypothermia or dangerous overcooling of the body. Sometimes, these unusual climatic conditions may cause unfortunate death of people. So we have designed a jacket, named as “Smart Jacket”, which is aimed to give better protection to the people living in extreme weather conditions and also for Industry. The Smart-Jacket is very much useful especially for our industry workers, working in extreme weather conditions. By using this jacket, the user can control and monitor the internal temperature of the person. GPS & GSM modules are also used in this jacket to trace the location of the worker and to send the alert messages in dangerous situations. This jacket also monitors the health condition of the worker’s body temperature, humidity, oxygen levels and heartbeat.

KEYWORDS: Raspberry pi, Heart and Pulse Rate Sensor, Temperature sensor

I. INTRODUCTION

The Industrial growth is increasing with the needs for the society. In this competition of production, a huge number of industries are facing problems with employee health and safety. As many of the workers are losing their life at work place, due to unawareness of their health conditions and also due to industrial hazards and accidents. Industrial workers are the key parts for running the industries, so their health and safety should be considered by any organization. As contribution to the industrial employee health and safety with emerging technologies such as internet of things a new concept is proposed with invention of smart jackets into the industries. A smart jacket is implemented with connected sensors for reading the employee health. As technology is improving in industries with the fourth revolution with IIoT (Industrial Internet of Things). Where the worker is in a connected network while wearing this smart jackets. As the smart jacket is equipped with different sensors such as heart and pulse rate sensors, temperature sensor, smoke and gas sensor, flame sensor. The heart and pulse rate sensor, temperature sensor which will monitor the health conditions of the employee from time to time on report to the higher authorities through the GSM and GPS modules. So using this information the managing team of the industry will be aware of health conditions of the employee and certain immediate measures are taken if any worker is affected with any health issues.

The health of the sensors for every second is monitored without any interruption to them. For the prevention of any accident from the work place different safety precaution sensors such as smoke and gas sensor, temperature sensor are also attached with the smart jacket in such a way that if any of the worker is about to be affected with any of the hazard this will sense beforehand and the several immediate measures are taken as of giving an alert to the worker by the buzzer, so that he and his co-workers will be aware of it and will be saved from the hazardous situations before they leads to the accidents

II.METHODOLOGY

The health condition of the workers and dangerous situations like fire attacks and the release of dangerous gases are monitored by our “Smart Jacket”. If any health issues will find in any worker and also in any dangerous situations the alert message and location will be sent and also the buzzer makes the sound. Here the Block Diagram of smart jacket for industrial employees as shown in Figure .1

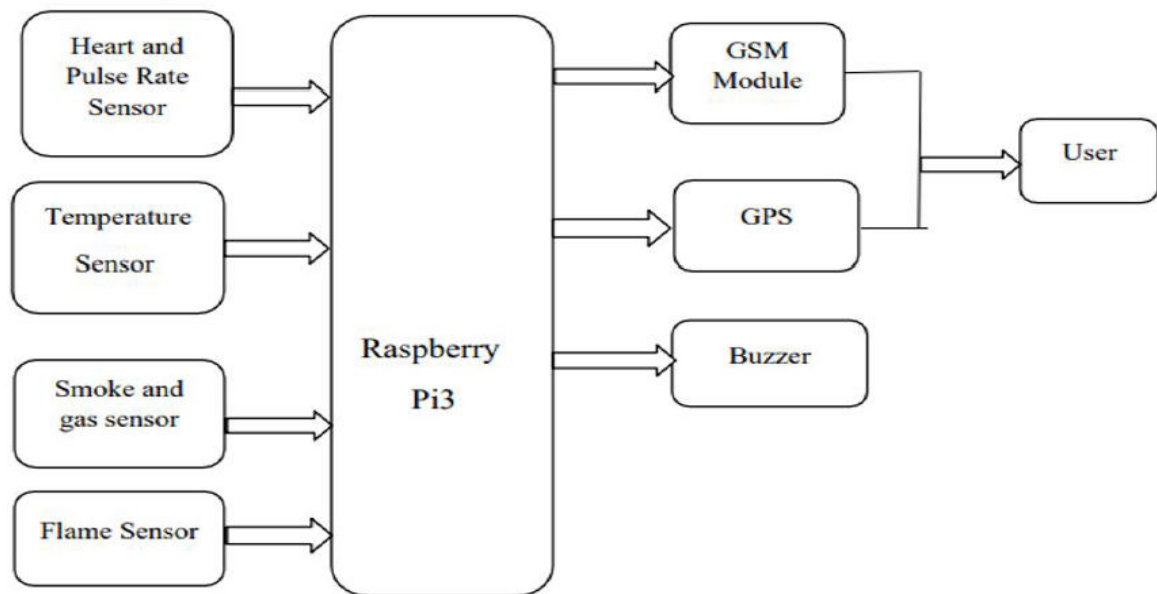

Fig.1 Block Diagram of Proposed System

In this project the heart and pulse rate sensor, temperature sensor, smoke and gas sensor and flame sensor takes the input from the external environment and this collected information is given to the Raspberry pi 3B+, here it can process that information and then according to that information output Devices can sends the alert messages to the user through GSM Module and location will be sent with the help of the GPS Module and the Buzzer alerts the people in surroundings.

III.HARDWARE REQUIREMENTS

3.1.RASPBERRY PI 3B+:

Raspberry pi is a series of small single-board computers (SBC is a complete computer built on a single circuit board, with microprocessors, memory, input/output and other features required of a functional computer) developed by the Raspberry Pi foundation as shown in Figure2.2. All models feature a broad com system on chip (SoC) with an integrated ARM compatible CPU and on-chip graphics processing unit (GPU). The foundation provides Raspberian (OS for Raspberry pi) based Linux distribution for download, as well as third-party windows10 IoT core, RISC OS, and specialized media center distributions. It promotes Python and Scratch as the main programming languages.

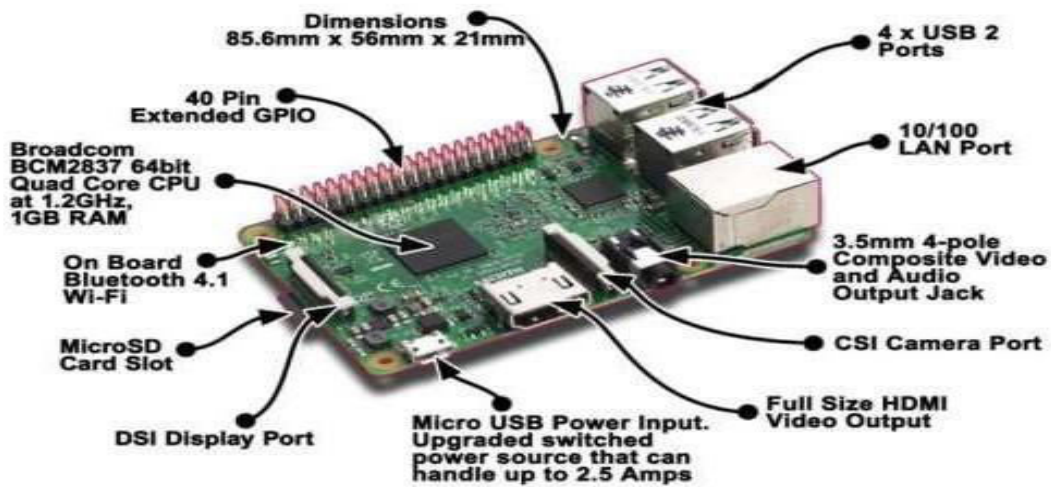

Fig.2 Raspberry Pi3

3.2. MAX 30100 HEART RATE OXYGEN PULSE SENSOR:

The sensor consists of a pair of Light emitting diode which emits monochromatic red light at a wavelength of 660nm and infrared light at a wavelength of 940 nm. These wavelengths are particularly chosen as at this wavelength oxygenated and deoxygenated hemoglobin have very different absorption properties. As shown in the graph below, it can be seen that there is a difference between HbO₂(oxygenated Hb) and Hb (deoxygenated Hb) when subjected to these specific wavelengths.



Fig.4.Heart Beat Sensor

3.3 DHT 11 SENSOR:

The DHT11 is a commonly used Temperature and humidity sensor that comes with a dedicated NTC to measure temperature and an 8-bit microcontroller to output the values of temperature and humidity as serial data. The DHT11 is a commonly used Temperature and humidity sensor. The sensor comes with a dedicated NTC to measure temperature and an 8-bit microcontroller to output the values of temperature and humidity as serial data. The sensor is also factory calibrated and hence easy to interface with other microcontrollers. The sensor can measure temperature from 0°C to 50°C and humidity from 20% to 90% with an accuracy of ±1°C and ±1%. So if you are looking to measure in this range then this sensor might be the right choice for you. The figure 2.4 represents DHT11 Sensor

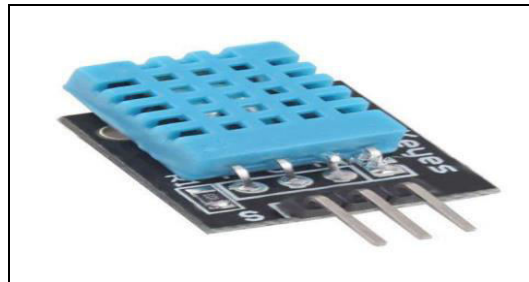

Fig.5.Humidity Sensor

FLOW CHART

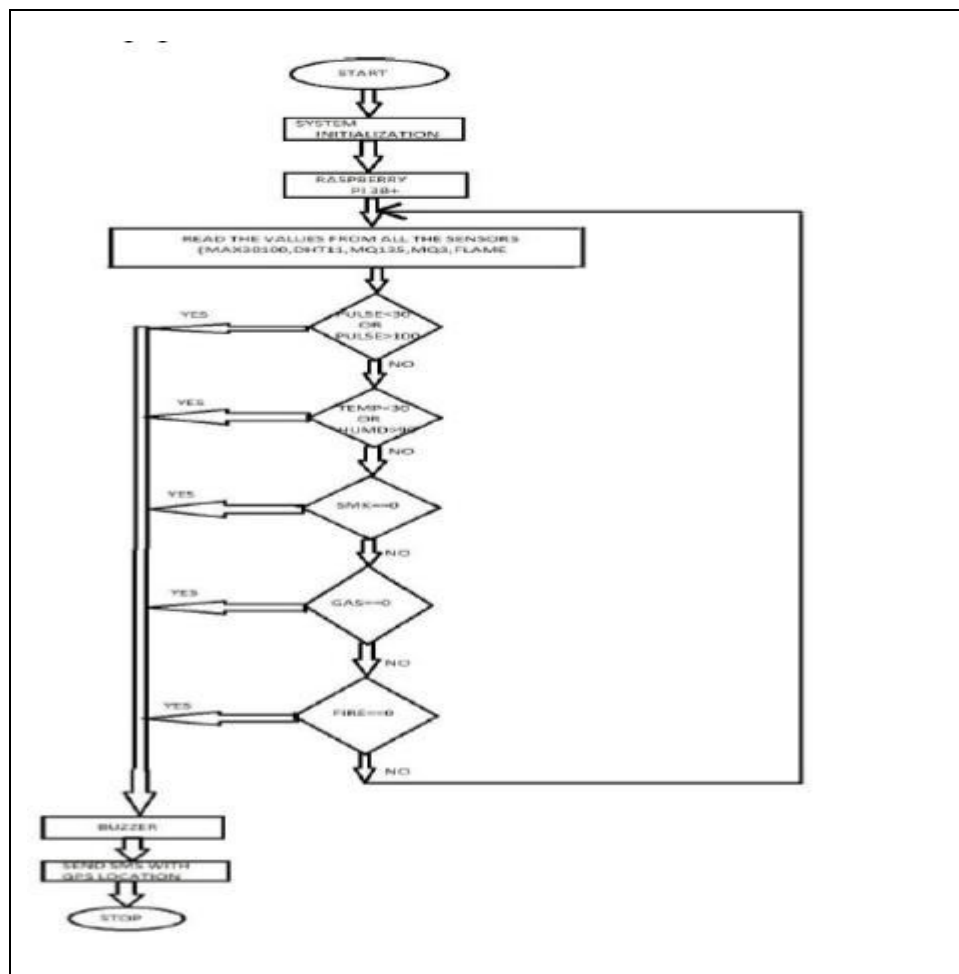

Fig.6.Flowchart of Proposed System

IV.RESULT & CONCLUSION

This project presents smart way of monitoring the health condition of the Industrial employees and the hazardous situation in the working environment. The result shows that higher sensitivity and accuracy is indeed achieved using this project. We made this the project more user friendly, eco friendly and reliable. The proposed method is verified to be highly beneficial for the industrial employees. This application provides the optimum solution to the employees working in the industries. We have presented the module approach for any employees in the industrial sector. We have successfully implemented this project using RASPBERRY PI 3B+. In all cases, our technology successfully detected all sorts of danger. The goals of the module will be fulfilled with the increase in the technology

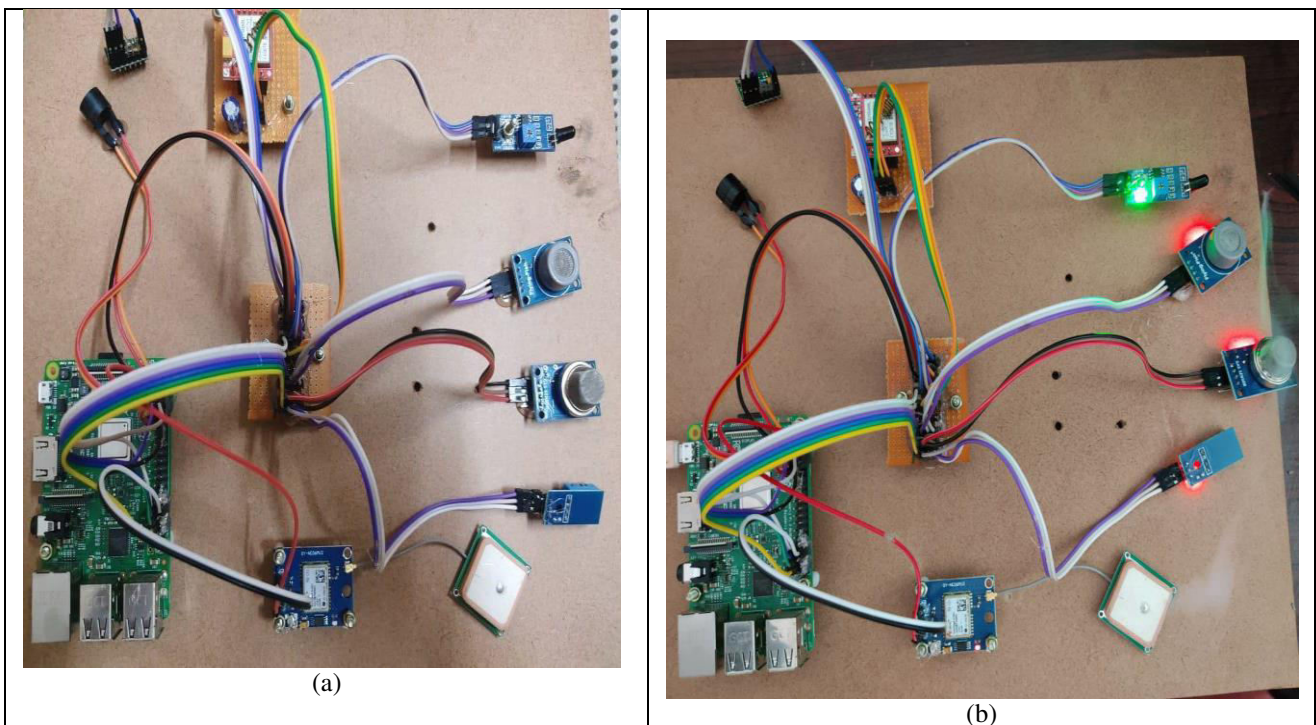

Fig.6. (a) Smart Jocket without Power supply (b) .Smart Jocket with Power Supply

When gas is placed in front of the gas sensor. The following messages send to predefined telephone numbers. Buzzer will on. Location also will be shared to particular telephone numbers.

Finally, the project was concluded by proposing an idea of Smart jacket for the Industrial employees. It can monitor the health condition of the employees and also gives the intimation regarding hazardous situations. If we use this technology in the underground mines by increasing the signal strength then it is very useful to the workers who are working in the mining area, because we are seeing that so many people are losing their life's for working under mines due to less efficient technology under mines. If we use this technology for the soldiers then it is very useful because soldiers are always at the borders of our country they won't take care of their health.

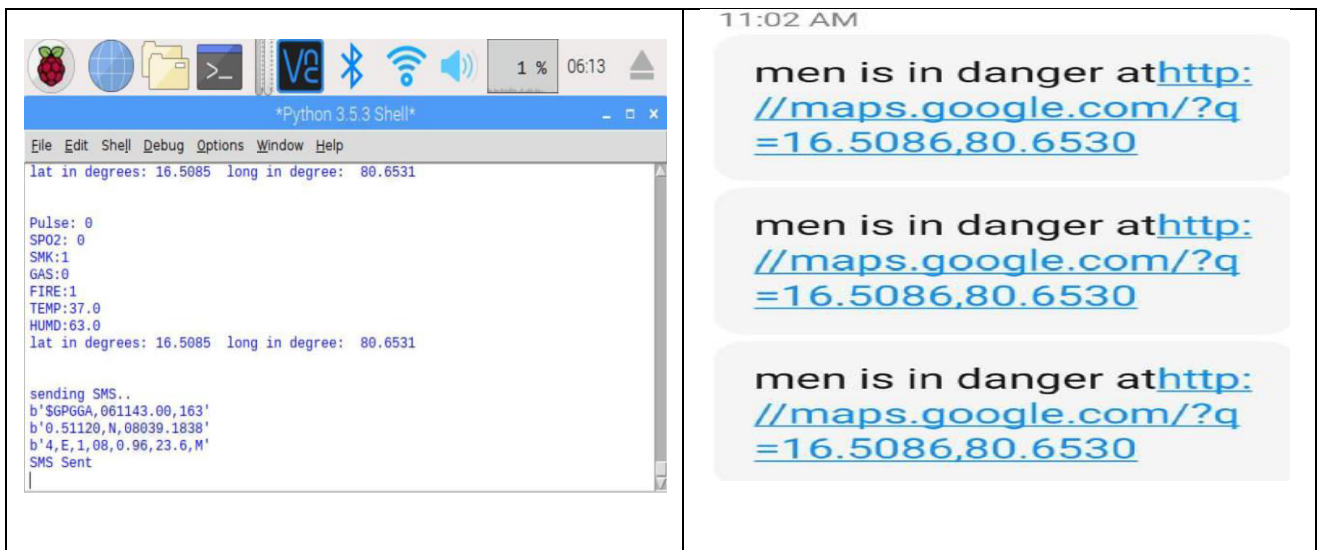

Fig.7.Messages

REFERENCES

- [1] Williams, T. A., & Williams, D. A. (1998). U.S. Patent No. 5,738,046. Washington, DC: U.S. Patent and Trademark Office..
- [2]R. Gorli, "World Laying Steps towards Smart Ideas", International Journal of Advanced Research in Computer and Communication Engineering, Vol.6, Issue.2, pp. 396-401, 2017..
- [3]. Lymberis, A. (2003, April). Smart wearables for remote health monitoring, from prevention to rehabilitation: current R&D, future challenges. In Information Technology Applications in Biomedicine, 2003. 4th International IEEE EMBS Special Topic Conference on (pp. 272-275). IEEE.
- [4].International Journal of Scientific Research in Computer Science, Engineering and Information Technology © 2017 IJSRCSEIT | Volume 2 | Issue 3 | ISSN: 2456-3307.
- [5].L. Piccini, O. Ciani, E. Grönvall, P. Marti, and G.Andreoni, "New monitoring approach for Neonatal Intensive Care Unit," in 5th International Workshop on Wearable Micro and Nano systems for Personalized Health, 2008.
- [6]Jasvinder Singh Chhabra¹, Akshay Chhajed¹, Shamlee Pandita¹, Suchita Wagh² "GPS and IoT Based Soldier Tracking & Health Indication System" International Research Journal of Engineering and Technology Volume: 04 Issue: 06 | June-2017
- [7].Vaishnavi Patil, Sanjay Singh Thakur,Vaibhav Kshirsagar "Health Monitoring System using Internet of Things" Proceedings of the Second International Conference on Intelligent Computing and Control Systems (ICICCS 2018).
- [8]. Shubhangi Gupta, Shivani Kulshrestha, Divya Singh, Ashish Kumar, Er.Hitendra Singh "GPS and GSM Based Soldier Health Monitoring and Tracking System" International Journal of Advanced Research in Electrical, Electronics and Instrumentation Engineering, Vol. 6, Issue 3, March 2017.



INNO  SPACE
SJIF Scientific Journal Impact Factor

Impact Factor: 8.165

 **doi**[®]
cross **ref**

ISSN INTERNATIONAL
STANDARD
SERIAL
NUMBER
INDIA



INTERNATIONAL JOURNAL OF INNOVATIVE RESEARCH

IN COMPUTER & COMMUNICATION ENGINEERING

 9940 572 462  6381 907 438  ijircce@gmail.com



www.ijircce.com

Scan to save the contact details