



# International Journal of Innovative Research in Computer and Communication Engineering

(A High Impact Factor, Monthly, Peer Reviewed Journal)

Website: [www.ijircce.com](http://www.ijircce.com)

Vol. 7, Issue 8, August 2019

## Survey on Vehicle Tracking and Security Using IOT

Jwala Vasantrya Rathod.<sup>1</sup>

P.G. Student, Deogiri Institute of Engineering and Management Studies, Aurangabad, MH, India<sup>1</sup>

**ABSTRACT:** Transportation is a must for today's life. It's make human life more easy and comfortable. Now days an accident ratio is increasing tremendously each and every day. Most of the vehicle are been theft, so we are going to introduce the system with the help of which the injured person can be traced by the exact location of vehicle provided by the sensor. In our proposed system we are going to introduce the technology to trace the exact location of the vehicle through sensors. If the vehicles are stolen then our system will track down the vehicles and gives us the coordinates and also sends a SMS to the owners and police, we also have web interface to lock vehicle. For preventing accidents different sensor are used such as alcohol sensor which will sense the driver is drunk or not, if the driver is drunk then the system will turn off the ignition and will give alert beeps and incase if accident happens then the location of the vehicle is track as mentioned above and notification SMS is send to hospitals and the concerned person of their family. We also used heartbeat sensor to detect health of driver if found ill and will give alert beeps.

**KEYWORDS:** Arduino UNO, API, GPS, RFID, sensor (accelerometer ADXL345, Pulse Sensor, PIR).

### I. INTRODUCTION

In today's era, the number of automobiles has increased exponentially due to growth in the automobile industry. There are increasing in number of vehicle technology, the accident also increases. The reasons for most of the road accident are rash driving and hectic traffic.

The main aim of the system is to construct a control system that provides the complete control of the interface. The main aim of system is to provide an interface to send and receive SMS to provide coordinates for security purpose instead of being physically present at that place. The main aim of system is to build an advanced lock system for automobile. In these system the user send and receive the SMS through SMS module. When the user receive the SMS and if the message is validated by SMS module then the system send the latitude/longitude of that place but if it is found that the bike is theft then also the user receives the SMS and get the coordinates and the user can also turn OFF the ignition . General objectives of the project are defined as-

- a) to identify the co-ordinate of vehicle through Short Message Service (SMS).
- b) To conformal receive and transmit data via SMS.
- c) To eliminate the need of being physically present at any location for security purpose.

Accident notification system use SMS and GPS, the main purpose of this project is to find the location of the accident in any place and send message and GPS. SMS technology is used for a mobile phone communication. PS is used to track the position of the automobile. Nowadays accidents are increasing at higher rate, this system provides to find accident location in remote areas and makes a hope in survival by providing the availability of ambulance or hospital as soon as possible. There are many other applications that can be used, such as the alcohol detection and the car theft. In case of vehicle theft we can track vehicle using web interface and by locking ignition system provided much needed security. There is also web history Module provided that we can see traveling history by providing that day date.

# International Journal of Innovative Research in Computer and Communication Engineering

(A High Impact Factor, Monthly, Peer Reviewed Journal)

Website: [www.ijircce.com](http://www.ijircce.com)

Vol. 7, Issue 8, August 2019

## II. SYSTEM OVERVIEW

In our proposed system we are going to introduce the technology using RFID and microcontroller ARDUINO. The power supply is connected to our microcontroller ARDUINO which connects all the sensors and records the data.

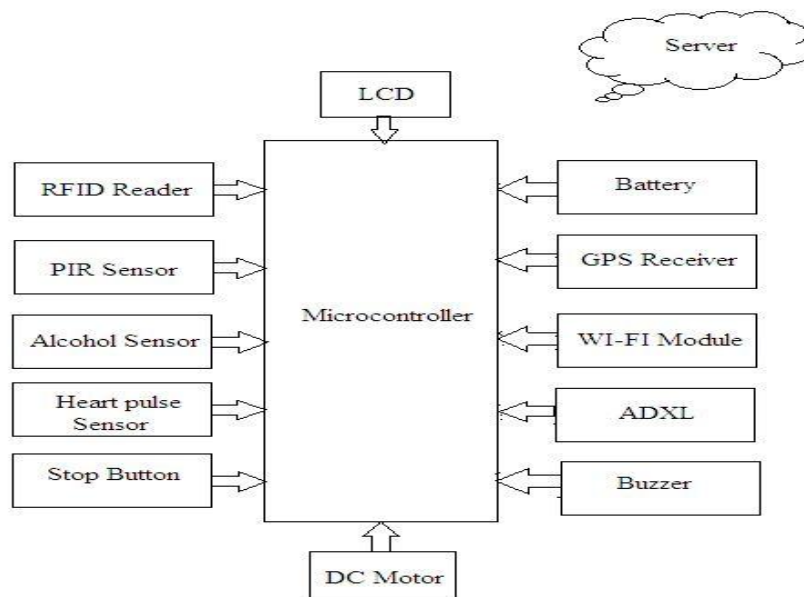

Figure 1: Accidental Detection

As seen in architecture we have power supply connected to ARDUINO. ARDUINO is connected to RFID, PIR, ADXL, LCD, GPS and ALCOHOL Sensor, Pulse sensor. The RFID reader is connected to ARDUINO and The RFID tag are matched with reader for authenticating tag and the ignition of vehicle is done if the tag is valid. The GPS is used for tracking. The GPS sends the coordinates to Webserver and all the data are stored in the server. The PIR senses the presence of living thing near the vehicle and sends data to ARDUINO which will give the alert buzzer. All the emergency details are stored on the server and are accessed through internet in association with microcontroller.

- A. ARDUINO UNO:** It is a microcontroller development board made using ATmega328. ATmega328 has 14 digital IO pins 6 analog inputs. All the operations are done in association with ARDUINO. It performs all necessary operations.
- B. POWER SUPPLY:** A power supply is an electronic device that supplies electrical energy. Here ARDUINO Uno, sensor, GPS, operates with 5v DC supply.
- C. GPS:** Global Position System (GPS) is a navigating system which is used to track down the vehicle in proposed system.
- D. PIR:** PIR is motion based sensor used to check the presence. if there is presence of any moving thing it will send the notification to user.
- E. ACCELEROMETER:** We are going to use the accelerometer for checking the tilt of vehicle angle and if the vehicle tilts by certain angle that is vehicle falls down it will send the notification to microcontroller.
- F. Pulse Sensor:** The heartbeat sensor is based on the principle of photo plethysmography. It counts the change in volume of blood through any organ of the body which causes a change in the light intensity through that organ (a



# International Journal of Innovative Research in Computer and Communication Engineering

*(A High Impact Factor, Monthly, Peer Reviewed Journal)*

Website: [www.ijirccce.com](http://www.ijirccce.com)

**Vol. 7, Issue 8, August 2019**

vascular region). In case of applications where heart pulse rate monitored. If it goes beyond threshold value we will get alert beeps.

## III. PROCEEDING METHODOLOGY AND DISCUSSIONS

This system is efficient and also worthy to be implemented. Accident detection and antitheft technology can be fitted in automobile that can save someone life and also the emergency services like ambulance and police to determine the scene at the same instance. The GPS is used to take the coordinates and the SMS api will send the SMS. Thus the emergency helpline can be able to determine the scene and take the immediate action. The GPS traces the coordinates and the Server will send the SMS to the contact and the sensors are used to measure physical values and if the threshold value is crossed the LCD will display the accident location using GPS system.

### A. ALGORITHM

- 1) Start
- 2) Press RFID CARD to RFID reader. If there is a match start the ignition else stop and lock the vehicle.
- 3) If accident occurs send the coordinates to emergency contacts.
- 4) If the vehicle is theft then inform the owner and stop the ignition and send the coordinates through SMS.
- 5) Stop.

## IV. LITERATURE SURVEY

From 1] the concept of RFID based accidental detection as well as the tracking of vehicle theft is referred. With the help of this paper the concept of RFID is properly understood. The proper functioning of RFID and interaction with microcontroller is studied better with it. All the algorithms related to RFID are studied effectively and the interaction of microcontroller and the automobile was properly interpreted which increased our interest in these system.

From 2] the Counting algorithms of RFID as well as all the RFID operation for tag matching are referred. Here the algorithm for interfacing the RFID with the microcontroller and the server was effective as well as the used algorithm was very well designed with lesser time complexity and system can trace the vehicle in fraction of seconds with this effective algorithm. This paper referred to many other algorithms but they were not much effective as like counting algorithm which is mentioned in [2] and due to its effectiveness it will be used in our proposed system. The overall functioning of our proposed system will be depending on this counting algorithm, so in our proposed system we try to boost up this existing algorithm for better output.

From 3] the communication between sensors and microcontrollers is studied and it also refers to the working principle of sensors. The sensors like ADXL, pressure, etc., are interfaced with the microcontroller as well as the interfacing technique and the sensors are used at its fullest strength and also the drawbacks of sensors were given which helped in making better decision on which sensor to be selected for better output. This paper gave the best knowledge for functioning of sensors.

In 4] the use of RFID and the communication with the server is studied and it also focuses on the study and the use of messaging API (application program interface) for sending the messages and sending the coordinates. In our system server is used to save the emergency details of the person and the API is used for sending the messages. Thus this paper helped a lot for interfacing the server with RFID through microcontroller as well as it covered API and its message communication which we are going to use in our proposed system. We know proper RFID tag details are to be stored in server in order to properly match the tag with reader to provide proper authentication to its true owner, so paper [4] gave us the better knowledge to interface these system and make our proposed system effective for use.

From 5] the concept of microcontroller ARDUINO UNO, its operations and its programming is studied here. The ARDUINO is the heart of our proposed system. All the functioning of the sensors is based on the functioning of ARDUINO microcontroller; hence it is essential to study ARDUINO microcontroller, its operation and programming. In our proposed system the microcontroller controls all the functioning like tracking as well as sending of alerts messages. Thus paper [5] is very helpful as it covers ARDUINO microcontroller as well as it helps to achieve better system.



# International Journal of Innovative Research in Computer and Communication Engineering

(A High Impact Factor, Monthly, Peer Reviewed Journal)

Website: [www.ijirccce.com](http://www.ijirccce.com)

Vol. 7, Issue 8, August 2019

As per the above references we are going to introduce a system for accidental detection using RFID. In this proposed system the new concept is the alcohol sensing and sensing the moving creatures. With the help of alcohol sensors the drivers will be checked if he is drunk or not and If the driver is found drunk the vehicle will give an alert buzzer and will stop the ignition. To protect the vehicle from being theft we are placing PIR sensors which will detect the movement of creatures near the vehicle and if the creatures are detected the owner will get the emergency text and also the system will flash lights around the vehicle with the sound alert. Our proposed system will be beneficial on highways and out layers to provide emergency services as soon as possible which will save many human life'

## V.FUTURE SCOPE

Further this system can use the sound detecting system such as sonar to detect accident. The system can use RFID instead of GPS for tracking which will provide more accuracy as the GPS does not show the exact location within 10m radius. The smartphone camera can be used to capture the images of vehicle met with accident which will help in determining the critical condition of driver.

## VI.CONCLUSION

We are going to introduce the system which will be very beneficial in the outliers and rural areas where the emergency services cannot reach immediately.so with the help of our proposed system the person can be tracked immediately and the person can be rescued as soon as possible which will save a human life.. Hence we are introducing the system that will also prevent theft of vehicle which will save the middleclass man from a great loss. Our proposed system is not so convenient in city as the emergency services are available easily but on highways and rural areas where there is scarce of emergency service our system is beneficial.

## VII. ACKNOWLEDGEMENT

We would like to acknowledge the support lent by our guide Dr R.M Autee and Director Dr. Ulhas Shiurkar. They were always available to address our queries and lead us in the right direction. Their encouragement and faith in us proved to be extremely helpful for us. Their knowledge and experience came to rescue us from the times when we were stuck at a point. We thank them for guiding us.

## REFERENCES

- [1] Fatima Nafar,Hosseinshamshi,"Design andImplementation of an RFID-GSM-Based VehicleIdentification System on Highways",IEEE Sensors Journal,Year: 2018 , Volume: 18 , Issue: 17,Pages: 7281 - 7293
- [2] W. K. Sze, Y. Deng, W. C. Lau, M. Kodialam, T. Nandagopal, O. Yue, "Channel-oblivious counting algorithms for large-scale RFID systems", *IEEE Trans.*
- [3] S. M. Tang and H. J. Gao, "Traffic-incident detection-algorithm based on nonparametric regression," *IEEE Transactions on Intelligent Transportation Systems*, vol. 6, 2005, pp. 38-42.
- [4] L. Chuan-zhi, H. Ru-fu, Y.E. Hong-wu, "Method of Freeway Incident Detection Using wireless Positioning," in *Proceedings of the IEEE International Conference on Automation and Logistics*, 2008, pp. 2801 - 2804.
- [5] C. Thompson, J. White, B. Dougherty, A. Albright, and D. C. Schmidt, "Using Smart phones to Detect Car Accidents and Provide Situational Awareness to Emergency Responders," in *3<sup>rd</sup> International ICST Conference on MOBILE Wireless MiddleWARE, Operating Systems, and Applications (Mobilware 2010)*, 2010.
- [6] R. Elvik, P. Christensen, A. Amundsen, "Speed and road accidents: an evaluation of the Power Model," *TOI Report*, [Online]. Accessed on 12 October 2011. Available: <http://www.trg.dk/elvik/740-2004.pdf>
- [7] NMEA 0183 Standard, [Online]. Accessed on 16 October 2011. Available:[http://www.nmea.org/content/nmea\\_standards/nmea\\_083\\_v\\_4\\_00.asp](http://www.nmea.org/content/nmea_standards/nmea_083_v_4_00.asp), Accessed on: 08 October 2011.