



International Journal of Innovative Research in Computer and Communication Engineering

(An ISO 3297: 2007 Certified Organization)

Vol. 4, Issue 6, June 2016

Smart Agriculture Using IoT and WSN Based Modern Technologies

Nikesh Gondchawar¹, Prof. Dr. R. S. Kawitkar²

Student, Dept. of Electronics and Telecommunication, Sinhgad College of Engineering, Pune, India¹

Professor, Dept. of Electronics and Telecommunication, Sinhgad College of Engineering, Pune, India²

ABSTRACT: Agriculture plays vital role in the development of agricultural country. In India about 70% of population depends upon farming and one third of the nation's capital comes from farming. Issues concerning agriculture have been always hindering the development of the country. The only solution to this problem is smart agriculture by modernizing the current traditional methods of agriculture. Hence the project aims at making agriculture smart using automation and IoT technologies. The highlighting features of this project includes smart GPS based remote controlled robot to perform tasks like weeding, spraying, moisture sensing, bird and animal scaring, keeping vigilance, etc. Secondly it includes smart irrigation with smart control and intelligent decision making based on accurate real time field data. Thirdly, smart warehouse management which includes temperature maintenance, humidity maintenance and theft detection in the warehouse. Controlling of all these operations will be through any remote smart device or computer connected to Internet and the operations will be performed by interfacing sensors, Wi-Fi or ZigBee modules, camera and actuators with micro-controller and raspberry pi.

KEYWORDS: IoT, automation, Wi-Fi, GPS, WSN, Smart Device

I. INTRODUCTION

Agriculture is considered as the basis of life for the human species as it is the main source of food grains and other raw materials. It plays vital role in the growth of country's economy. It also provides large ample employment opportunities to the people. Growth in agricultural sector is necessary for the development of economic condition of the country. Unfortunately, many farmers still use the traditional methods of farming which results in low yielding of crops and fruits. But wherever automation had been implemented and human beings had been replaced by automatic machineries, the yield has been improved. Hence there is need to implement modern science and technology in the agriculture sector for increasing the yield. Most of the papers signifies the use of wireless sensor network which collects the data from different types of sensors and then send it to main server using wireless protocol. The collected data provides the information about different environmental factors which in turns helps to monitor the system..

Monitoring environmental factors is not enough and complete solution to improve the yield of the crops. There are number of other factors that affect the productivity to great extent. These factors include attack of insects and pests which can be controlled by spraying the crop with proper insecticide and pesticides. Secondly, attack of wild animals and birds when the crop grows up. There is also possibility of thefts when crop is at the stage of harvesting. Even after harvesting, farmers also face problems in storage of harvested crop. So, in order to provide solutions to all such problems, it is necessary to develop integrated system which will take care of all factors affecting the productivity in every stages like; cultivation, harvesting and post harvesting storage.

This paper therefore proposes a system which is useful in monitoring the field data as well as controlling the field operations which provides the flexibility. The paper aims at making agriculture smart using automation and IoT technologies. The highlighting features of this paper includes smart GPS based remote controlled robot to perform tasks like; weeding, spraying, moisture sensing, bird and animal scaring, keeping vigilance, etc. Secondly, it includes smart irrigation with smart control based on real time field data. Thirdly, smart warehouse management which includes; temperature maintenance, humidity maintenance and theft detection in the warehouse. Controlling of all these operations will be through any remote smart device or computer connected to Internet and the operations will be performed by interfacing sensors, Wi-Fi or ZigBee modules, camera and actuators with micro-controller and raspberry pi.

International Journal of Innovative Research in Computer and Communication Engineering

(An ISO 3297: 2007 Certified Organization)

Vol. 4, Issue 6, June 2016

II. RELATED WORK

The newer scenario of decreasing water tables, drying up of rivers and tanks, unpredictable environment present an urgent need of proper utilization of water. To cope up with this use of temperature and moisture sensor at suitable locations for monitoring of crops is implemented in [1]. An algorithm developed with threshold values of temperature and soil moisture can be programmed into a microcontroller-based gateway to control water quantity. The system can be powered by photovoltaic panels and can have a duplex communication link based on a cellular-Internet interface that allows data inspection and irrigation scheduling to be programmed through a web page. [2] The technological development in Wireless Sensor Networks made it possible to use in monitoring and control of greenhouse parameter in precision agriculture. [3] After the research in the agricultural field, researchers found that the yield of agriculture is decreasing day by day. However, use of technology in the field of agriculture plays important role in increasing the production as well as in reducing the extra man power efforts. Some of the research attempts are done for betterment of farmers which provides the systems that use technologies helpful for increasing the agricultural yield. A remote sensing and control irrigation system using distributed wireless sensor network aiming for variable rate irrigation, real time in field sensing, controlling of a site specific precision linear move irrigation system to maximize the productivity with minimal use of water was developed by Y. Kim . The system described details about the design and instrumentation of variable rate irrigation, wireless sensor network and real time in field sensing and control by using appropriate software. The whole system was developed using five in field sensor stations which collects the data and send it to the base station using global positioning system (GPS) where necessary action was taken for controlling irrigation according to the database available with the system. The system provides a promising low cost wireless solution as well as remote controlling for precision irrigation. [4] In the studies related to wireless sensor network, researchers measured soil related parameters such as temperature and humidity. Sensors were placed below the soil which communicates with relay nodes by the use of effective communication protocol providing very low duty cycle and hence increasing the life time of soil monitoring system. The system was developed using microcontroller, universal asynchronous receiver transmitter (UART) interface and sensors while the transmission was done by hourly sampling and buffering the data, transmit it and then checking the status messages. The drawbacks of the system were its cost and deployment of sensor under the soil which causes attenuation of radio frequency (RF) signals. [5]

III. PROPOSED SYSTEM

The paper consist of four sections; node1, node2, node3 and PC or mobile app to control system. In the present system, every node is integration with different sensors and devices and they are interconnected to one central server via wireless communication modules. The server sends and receives information from user end using internet connectivity. There are two modes of operation of the system; auto mode and manual mode. In auto mode system takes its own decisions and controls the installed devices whereas in manual mode user can control the operations of system using android app or PC commands.

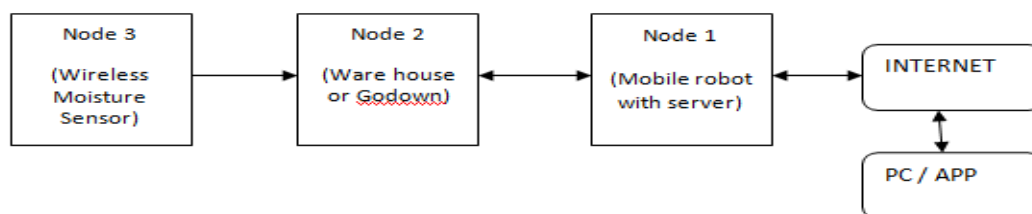

Figure 1: System overview

IV. ARCHITECTURE OF THE SYSTEM

Node 1:

Node1 is GPS based mobile robot which can be controlled remotely using computer as well as it can be programmed so as to navigate autonomously within the boundary of field using the co-ordinates given by GPS module

The Remote controlled robot have various sensors and devices like camera, obstacle sensor, siren, cutter, sprayer and using them it will perform tasks like; Keeping vigilance, Bird and animal scaring, Weeding, and Spraying

International Journal of Innovative Research in Computer and Communication Engineering

(An ISO 3297: 2007 Certified Organization)

Vol. 4, Issue 6, June 2016

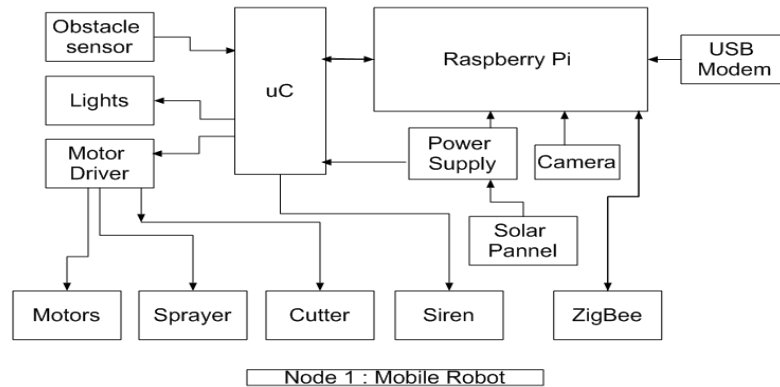

Figure 2: Node 1

Node 2:

Node2 will be the warehouse. It consists of motion detector, light sensor, humidity sensor, temperature sensor, room heater, cooling fan altogether interfaced with AVR microcontroller. Motion detector will detect the motion in the room when security mode will be ON and on detection of motion, it will send the alert signal to user via Raspberry pi and thus providing theft detection

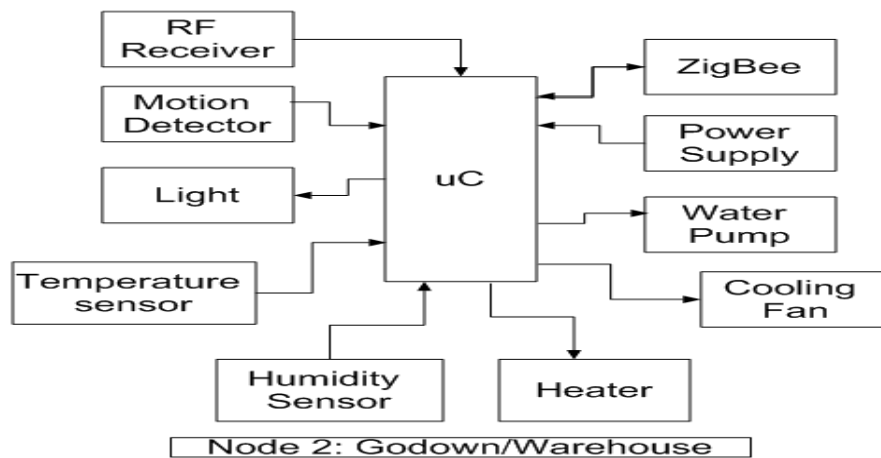

Figure 3: Node 2

Temperature sensor and Humidity sensor senses the temperature and humidity respectively and if the value crosses the threshold then room heater or cooling fan will be switched ON/OFF automatically providing temperature and humidity maintenance. Node2 will also controls water pump depending upon the soil moisture data sent by node3.

Node 3:

Node3 is a smart irrigation node with features like ; Smart control of water pump based on real time field data i.e. automatically turning on/off the pump after attaining the required soil moisture level in auto mode, Switching water pump on/off remotely via mobile or computer in manual mode, and continuous monitoring of soil moisture.

International Journal of Innovative Research in Computer and Communication Engineering

(An ISO 3297: 2007 Certified Organization)

Vol. 4, Issue 6, June 2016

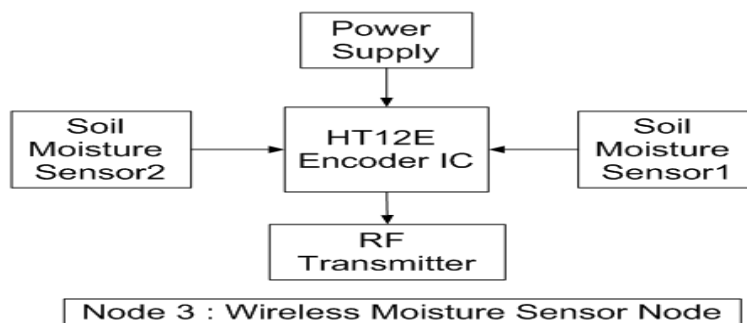

Figure 4: Node 3

In node3, moisture sensor transmits the data using HT12E Encoder IC and a RF transmitter. The transmitted data is received by node2 and there it is processed by microcontroller in order to control the operation of water pump.

Hardware used:

a) AVR Microcontroller Atmega 16/32:

The microcontroller used is, Low-power AVR® 8-bit Microcontroller, having 8K Bytes of In-System Self-programmable Flash program memory, Programmable Serial USART, 8-channel, 10-bit ADC, 23 Programmable I/O Lines.

b) ZigBee Module:

ZigBee is used for achieving wireless communication between Node1 and Node2. The range for Zigbee is roughly 50 meters and it can be increased using high power modules or by using network of modules. It operates on 2.4 GHz frequency. Its power consumption is very low and it is less expensive as compared to other wireless modules like Wi-Fi or Bluetooth. It is usually used to establish wireless local area networks.

c) Temperature Sensor LM35:

The LM35 is precision IC temperature sensor. Output voltage of LM35 is directly proportional to the Centigrade/Celsius of temperature. The LM35 does not need external calibration or trimming to provide accurate temperature range. It is very low cost sensor. It has low output impedance and linear output. The operating temperature range for LM35 is -55° to $+150^{\circ}$ C. With rise in temperature, the output voltage of the sensor increases linearly and the value of voltage is given to the microcontroller which is multiplied by the conversion factor in order to give the value of actual temperature.

d) Moisture sensor:

Soil moisture sensor measures the water content in soil. It uses the property of the electrical resistance of the soil. The relationship among the measured property and soil moisture is calibrated and it may vary depending on environmental factors such as temperature, soil type, or electric conductivity. Here, It is used to sense the moisture in field and transfer it to microcontroller in order to take controlling action of switching water pump ON/OFF.

e) Humidity sensor:

The DHT11 is a basic, low-cost digital temperature and humidity sensor. It gives out digital value and hence there is no need to use conversion algorithm at ADC of the microcontroller and hence we can give its output directly to data pin instead of ADC. It has a capacitive sensor for measuring humidity. The only real shortcoming of this sensor is that one can only get new data from it only after every 2 seconds.

f) Obstacle sensor (Ultra-Sonic):

The ultra-sonic sensor operates on the principle of sound waves and their reflection property. It has two parts; ultra-sonic transmitter and ultra-sonic receiver. Transmitter transmits the 40 KHz sound wave and receiver receives the reflected 40 KHz wave and on its reception, it sends the electrical signal to the microcontroller. The speed of sound in air is already known. Hence from time required to receive back the transmitted sound wave, the distance of obstacle is calculated. Here, it is used for obstacle detection in case of mobile robot and as a motion detector in ware house for preventing thefts. The ultra-sonic sensor enables the robot to detect and avoid obstacles and also to measure the distance from the obstacle. The range of operation of ultra-sonic sensor is 10 cm to 30 cm.

International Journal of Innovative Research in Computer and Communication Engineering

(An ISO 3297: 2007 Certified Organization)

Vol. 4, Issue 6, June 2016

g) Raspberry Pi :

The Raspberry Pi is small pocket size computer used to do small computing and networking operations. It is the main element in the field of internet of things. It provides access to the internet and hence the connection of automation system with remote location controlling device becomes possible. Raspberry Pi is available in various versions. Here, model Pi 2 model B is used and it has quad-core ARM Cortex-A53 CPU of 900 MHz, and RAM of 1GB. It also has: 40 GPIO pins, Full HDMI port, 4 USB ports, Ethernet port, 3.5mm audio jack, video Camera interface (CSI), the Display interface (DSI), and Micro SD card slot.

Softwares used:

a) AVR Studio Version 4:

It is used to write, build, compile and debug the embedded c program codes which are needed to be burned in the microcontroller in order to perform desired operations. This software directly provides .hex file which can be easily burned into the microcontroller.

b) Proteus 8 Simulator:

Proteus 8 is one of the best simulation software for various circuit designs of microcontroller. It has almost all microcontrollers and electronic components readily available in it and hence it is widely used simulator. It can be used to test programs and embedded designs for electronics before actual hardware testing. The simulation of programming of microcontroller can also be done in Proteus. Simulation avoids the risk of damaging hardware due to wrong design.

c) SinaProg:

SinaProg is a Hex downloader application with AVR Dude and Fuse Bit Calculator. This is used to download code/program and to set fuse bits of all AVR based microcontrollers.

d) Raspbian Operating System:

Raspbian operating system is the free and open source operating system which Debian based and optimized for Raspberry Pi. It provides the basic set of programs and utilities for operating Raspberry Pi. It comes with around 35,000 packages which are pre-compiled softwares that are bundled in a nice format for hustle free installation on Raspberry Pi. It has good community of developers which runs the discussion forms and provides solutions to many relevant problems. However, Raspbian OS is still under consistent development with an main focus on improving the performance and the stability of as many Debian packages as possible.

V. EXPERIMENTATION AND RESULTS

As shown in figure 5, experimental setup for node1 consists of mobile robot with central server, GPS module, camera and other sensors. All sensors are successfully interfaced with microcontroller and the microcontroller is interfaced with the raspberry pi. GPS and camera are also connected to raspberry pi.



Figure 5: experimental setup for Node1

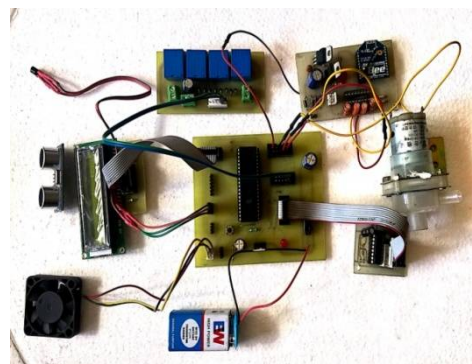

Figure 6: experimental setup for Node2

Test results shows that the robot can be controlled remotely using wireless transmission of PC commands to R-Pi. R-Pi forwards the commands to microcontroller and microcontroller gives signals to motor driver in order to drive the Robot. GPS module provides the co-ordinates for the location of the robot.

As shown in figure 6, node2 consists of motion detector, temperature sensor, humidity sensor, cooling fan, water pump, etc. connected to the microcontroller board. The sensors give input to the controller and according to that

International Journal of Innovative Research in Computer and Communication Engineering

(An ISO 3297: 2007 Certified Organization)

Vol. 4, Issue 6, June 2016

microcontroller controls the devices in auto mode and also sends the value of sensors to R-Pi and R-Pi forwards it to user's smart device using internet.

Test results shows that when temperature level increases above preset threshold level then cooling fan is started automatically in auto mode. The water pump also gets turned ON if moisture level goes below fixed threshold value. In manual mode, microcontroller receives the controlling signals from R-Pi through ZigBee and accordingly takes the control action.

As shown in figure 7, node3 consists of a moisture sensor connected to HT12E. Moisture sensor transmits the data using HT12E Encoder IC and a RF transmitter to the Node2 where it is processed by microcontroller and accordingly water pump is switched ON/OFF

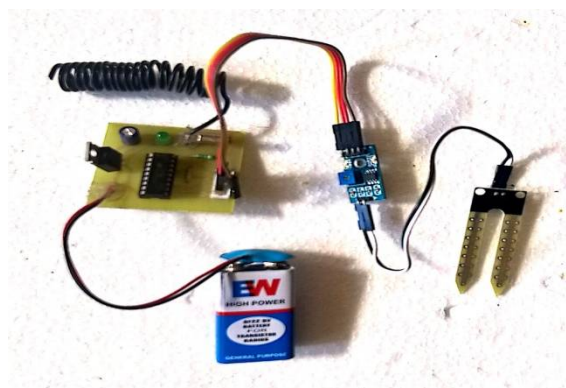

Figure 7: experimental setup for Node3

VI. CONCLUSION

The sensors and microcontrollers of all three Nodes are successfully interfaced with raspberry pi and wireless communication is achieved between various Nodes. All observations and experimental tests proves that project is a complete solution to field activities, irrigation problems, and storage problems using remote controlled robot, smart irrigation system and a smart warehouse management system respectively. Implementation of such a system in the field can definitely help to improve the yield of the crops and overall production.

REFERENCES

1. S. R. Nandurkar, V. R. Thool, R. C. Thool, "Design and Development of Precision Agriculture System Using Wireless Sensor Network", IEEE International Conference on Automation, Control, Energy and Systems (ACES), 2014
2. Joaquín Gutiérrez, Juan Francisco Villa-Medina, Alejandra Nieto-Garibay, and Miguel Ángel Porta-Gándara, "Automated Irrigation System Using a Wireless Sensor Network and GPRS Module", IEEE TRANSACTIONS ON INSTRUMENTATION AND MEASUREMENT, 0018-9456, 2013
3. Dr. V. Vidya Devi, G. Meena Kumari, "Real-Time Automation and Monitoring System for Modernized Agriculture", International Journal of Review and Research in Applied Sciences and Engineering (IJRRASE) Vol3 No.1. PP 7-12, 2013
4. Y. Kim, R. Evans and W. Iversen, "Remote Sensing and Control of an Irrigation System Using a Distributed Wireless Sensor Network", IEEE Transactions on Instrumentation and Measurement, pp. 1379-1387, 2008.
5. Hayes, J.; Crowley, K.; Diamond, D. Simultaneous web-based real-time temperature monitoring using multiple wireless sensor networks. Sensors IEEE, October 30-November 3, 2005, p. 4.
6. Q. Wang, A. Terzis and A. Szalay, "A Novel Soil Measuring Wireless Sensor Network", IEEE Transactions on Instrumentation and Measurement, pp. 412-415, 2010
7. Yoo, S.; Kim, J.; Kim, T.; Ahn, S.; Sung, J.; Kim, D. A2S: Automated agriculture system based on WSN. In ISCE 2007. IEEE International Symposium on Consumer Electronics, 2007, Irving, TX, USA, 2007
8. Arampatzis, T.; Lygeros, J.; Manesis, S. A survey of applications of wireless sensors and Wireless Sensor Networks. In 2005 IEEE International Symposium on Intelligent Control & 13th Mediterranean Conference on Control and Automation. Limassol, Cyprus, 2005, 1-2, 719-724
9. Orazio Mirabella and Michele Brischetto, 2011. "A Hybrid Wired/Wireless Networking Infrastructure for Greenhouse Management", IEEE transactions on instrumentation and measurement, vol. 60, no. 2, pp 398-407.
10. N. Kotamaki and S. Thessler and J. Koskiaho and A. O. Hannukkala and H. Huitu and T. Huttula and J. Havento and M. Jarvenpaa (2009). "Wireless in-situ sensor network for agriculture and water monitoring on a river basin scale in Southern Finland: evaluation from a data users perspective". Sensors 4, 9: 2862-2883. doi:10.3390/s90402862 2009.
11. Liu, H.; Meng, Z.; Cui, S. A wireless sensor network prototype for environmental monitoring in greenhouses. International Conference on Wireless Communications, Networking and Mobile Computing (WiCom 2007), Shanghai, China; 21-25 September 2007.



ISSN(Online): 2320 - 9801
ISSN (Print) : 2320 - 9798

International Journal of Innovative Research in Computer and Communication Engineering

(An ISO 3297: 2007 Certified Organization)

Vol. 4, Issue 6, June 2016

12. Baker, N. ZigBee and bluetooth - Strengths and weaknesses for industrial applications. *Comput. Control. Eng.* **2005**, 16, 20-25.
13. IEEE, Wireless medium access control (MAC) and physical layer (PHY) specifications for lowrate wireless personal area networks (LR-WPANS). In *The Institute of Electrical and Electronics Engineers Inc.*: New York, NY, USA, 2003.

BIOGRAPHY

¹Nikesh Govardhan Gondchawar, PG Student, E&TC Department, Sinhgad college of Engineering, Pune, India,

² Prof. Dr. Rameshwar Shankarrao Kawitkar, Professor, E&TC Department, Sinhgad college of Engineering, Pune, India