



# **Design and Implementation of Network Chip for Wireless and Wired Peripherals with Serial Communication**

Anjali Devan P<sup>1</sup>, Aby Mathew<sup>2</sup>

PG Student, Dept. of ECE, SNGCE, Kadayiruppu, MG University Kerala, India<sup>1</sup>

Assistant Professor, Dept. of ECE, SNGCE, Kadayiruppu, MG University Kerala, India<sup>2</sup>

**ABSTRACT:** Wireless sensor networks (WSNs) have gained worldwide attention in recent years. Unlike traditional networks, a WSN has its own design and resource constraints. Resource constraints include a limited amount of energy, short communication range, low bandwidth, and limited processing and storage in each node. However, the current connect number, sampling rate, and signal types of sensors are generally restricted by the device. In this paper, to solve these problems, a new method is proposed to design and implementation of network chip for wireless and wired peripherals with serial communication, in which filed programmable gate array (FPGA) is adopted as the core controller. Thus, it can read data in in real time with high speed on different sensor data. The standard of IEEE1451.2 intelligent sensor interface specification is adopted in this design. A new solution is provided for the traditional sensor data acquisitions. The device is combined with the FPGA programmable technology and the standard of IEEE1451.2 intelligent sensor specification. The performance of the proposed system is verified and good effects are achieved in practical application.

**KEYWORDS:** FPGA, IEEE1415 protocol, sensor data acquisition.

## **I. INTRODUCTION**

The current generation automation systems, control & monitoring systems, security systems, etc., all have the capability to share information over the network and are being increasingly employed to aid real-time decision support. The inter-device communication in such systems can be leveraged to maximize the efficiency and convenience in a variety of situations. Intelligent wireless sensors based controls have gained significant attention due to their flexibility, compactness and ease of use in remote unattended locations and conditions. These wireless sensor modules can be designed to combine sensing, provide in-situ computation, and contact-less communication into a single, compact device, providing ease in deployment, operation and maintenance. Already large-scale wireless sensor networks having different capabilities are being used to monitor real-time application needs.

A sensor network consists of a set of sensor nodes made up of one or several processing elements, sensors, a small battery and a wireless transceiver which sends measurements from the sensors to a gateway that routes the data towards a logging system. Communications are typically based on the IEEE 802.15.4 standard due to its focus on low-power communications and simplicity. However, 802.11 links are also used in gateways for high-speed data transmission. The upper layers are usually based on the ZigBee Alliance stack or on optimized research layers such as S-MAC or T-MAC in the case of the Medium Access Layer (MAC).

However, sensor nodes suffer from several critical requirements: the fabrication cost of the node, energy consumption and its processing capabilities, both individual and distributed. Energy efficiency in a sensor node is essential, given that either recharging or replacing the battery of hundred nodes can be a time-consuming task. Consequently, the main challenge in WSNs is reducing the power consumption of the nodes. A typical strategy consists of reducing the transmission of data among the sensor nodes. Thus, an additional intelligent layer is required in order to provide an extra level of processing with the aim of compressing the sensor measurements into short messages, alerts or information about events. Other power minimization strategies consist of reducing the duty cycle, changing



# International Journal of Innovative Research in Computer and Communication Engineering

(An ISO 3297: 2007 Certified Organization)

Vol. 3, Issue 8, August 2015

dynamically the frequency and turning on the radio transceiver selectively. In this respect, since the processing capabilities of sensor nodes are quite limited and rely on microcontrollers, Field-Programmable Gate Arrays (FPGAs) can play a key role.

Nowadays, FPGAs are crossing the 28 nm CMOS threshold. Such platforms can add extra processing capabilities to a typical sensor node with a reduced energy consumption if they are turned on when required by a microcontroller. Moreover, state-of-the-art FPGAs consist of powerful processing capabilities, based on ASIC arithmetic components such as high-speed multipliers and adders. Hence, the FPGAs can provide strong cryptography capabilities and high-speed acceleration of algorithms such as compression, image processing, and routing. This explores the use and possibilities of FPGAs in sensor node architectures and their applications, focusing on the level of power consumption and the proper optimization of the current embedded resources of novel FPGAs.

## II. RELATED WORK

A reconfigurable smart sensor interface for industrial WSN in IoT environment [1] is designed based on IEEE1451 protocol by combining with CPLD and the application of wireless communication. It is very suitable for real-time and effective requirements of the high-speed data acquisition system in IoT environment. The application of CPLD greatly simplifies the design of peripheral circuit, and makes the whole system more flexible and extensible. Application of IEEE1451 protocol enables the system to collect sensor data intelligently. Different types of sensors can be used as long as they are connected to the system. Main design method of the reconfigurable smart sensor interface device is described in this paper. Finally, by taking real time monitoring of water environment in IoT environment as an example, they verified that the system achieved good effects in practical application.

WSNs are traditionally considered key enablers for the IoT Paradigm [2]. However, due to the widening variety of applications, it is increasingly difficult to define common requirements for the WSN nodes and platforms. This addresses all phases of the practical development from scratch of a full custom WSN platform for environmental monitoring IoT applications. It starts by analysing the application requirements and defining a set of specifications for the platform. A real-life, demanding application is selected as reference to guide most of node and platform solution exploration and the implementation decisions.

All aspects of the WSN platform are considered: platform structure, flexibility and reusability, optimization of the sensor and gateway nodes, optimization of the communication protocols for both in-field and long range, error recovery from communications and node operation, high availability of service at all levels, application server reliability and the interfacing with IoT applications. Of particular importance are IoT requirements for low cost, fast deployment, and long unattended service time. All platform components are implemented and support the operation of a broad range of indoor and outdoor field deployments with several types of nodes built using the generic node platforms presented. This demonstrates the flexibility of the platform and of the solutions proposed. The flow presented in this paper can be used to guide the specification, optimization and development of WSN platforms for other IoT application domains.

Self-Adaptive Network-on-Chip Interface [3] presents an original approach of bandwidth Oriented self-adaptivity in the domain of network-on-chip, Where reconfiguration is handled by network interfaces offering Traffic with guarantee of service. Reconfiguration is first based on multiple first-in-first-outs (fifos) with variables bounds and Implemented in a single dual-port memory with a dedicated controller. Secondly, it relies on multiple and compliant TDMA tables Based on a new heuristic for path computation. Combination of both techniques provides significant bandwidth improvement with a negligible resource overhead.

The proposed solution is Demonstrated with cycle-accurate VHDL simulation and FPGA implementation for synthetic and image processing applications. Network-On-Chip (noc) have been introduced a Decade ago, as an innovative approach to meet the expected bandwidth in modern system-on-chip (soc) that Implement an increasing number of ips (processors, distributed Memories and peripherals). Nocs offer both performances and Scalability properties expected in large soc. Today, the noc Approach is completely adopted by industrial solutions. In this letter, we explore the concept of reconfigurable noc, which aims to introduce self-adaptive mechanisms in Nocs. Self adaptivity is required for various reasons, we mainly consider the two following aspects.



# International Journal of Innovative Research in Computer and Communication Engineering

(An ISO 3297: 2007 Certified Organization)

Vol. 3, Issue 8, August 2015

First, in distributed reconfigurable Soc, whatever the quality of service provided, the conventional noc are unable to handle constraints introduced by the load balancing mechanism. Secondly, in guaranteed traffic noc, the design methodology is based on estimations of application traffic, but data transfers May be very variable especially in case of data-dependent applications (e.g., video codecs, image processing, networking), which derive from energy-conscious optimizations. Moreover, the activation period of applications may change over time and consequently result in various configurations, which can be difficult to predict and model [3].

An RTOS-based Architecture for Industrial Wireless Sensor Network Stacks with Multi-Processor Support [4] presents the design of industrial wireless sensor network (IWSN)Stacks requires the adoption of real time operation system (RTOS).Challenges exist especially in timing integrity and multi-processorsupport. As a solution, we propose an RTOS-based architecturefor IWSN stacks with multi-processor support. It offers benefits in terms of platform independency, product life cycle, safety and security, system integration complexity, and performancescalability. An implemented wireless stack has proven the feasibility of the proposed architecture in practical product design.And future challenges as well as suggestions to standardImprovement are discussed.Here an RTOS-based architecture with multiprocessor support for IWSN protocol stacks. The advantages have been proven by a case study of Wireless HART stack that has been implemented on a low cost two processor platform. In the current prototype, we have noticed that, a huge amount of messages are transmitted between layers in addition to the effective packets. The primary reason is, in the Wireless HART standard, all the information in lower layers is managed through HART commands from the application layer. This is not an issue if we can use global variables to share all cross layer information.

But in the proposed architecture, these global variables have to be avoided to support multi-processor. Hence, a series of internal messages should be triggered between the application layer and lower layers to execute such a command. Besides the optimization of our architecture, to improve the standards to be more “RTOS and multi-processor friendly” is a feasible strategy. The hands on experiences gathered from practical implementations should be feedback to the design and update of the standards.Power consumption is another potential issue. The RTOS and IPC of the proposed architecture may consume extra energy. But the fundamental mechanisms of the protocol itself (e.g. the TDMA and security algorithms) might be the primary obstacle for low power design. So in our future plan, it is expected to be more effective to optimize the power consumption under a broader context, e.g. not only considering the stack implementation but also jointly looking into the protocols and the whole system integration architectures like field buses.

Compressed Sensing Signal and Data Acquisition in Wireless Sensor Networks and Internet of Things, investigates how CS canprovide new insights into data sampling and acquisition in wireless sensor networks and IoT. First, we briefly introduce the CS theorywith respect to the sampling and transmission coordination duringthe network lifetime through providing a compressed samplingprocess with low computation costs. Then, a CS-based frameworkis proposed for IoT, in which the end nodes measure, transmit,and store the sampled data in the framework. Then, an efficientcluster-sparse reconstruction algorithm is proposed for in-networkcompression aiming at more accurate data reconstructionand lower energy efficiency [5]. Performance is evaluated with respectto network size using datasets acquired by a real-life deployment. This work has shown that CS can be a powerful data acquisition tool for saving energy and communication resources in networks and information systems. It further strengthens the connection between information theory and CS.

Energy Efficient Scheduling for Cluster-Tree Wireless Sensor Networks with Time Bounded Data Flows: Application to IEEE 802.15.4/ZigBee [6] presents a methodology that provides a Time-Division Cluster Scheduling (TDCS) mechanism based on the cyclic extension of Resource Constrained Project Scheduling with Temporal Constraints (RCPS/TC) problem for a cluster-tree WSN, assuming bounded communication errors. The objective is to meet all end-to-end deadlines of a predefined set of time-bounded data flows while minimizing the energy consumption of the nodes by setting the TDCS period as long as possible. Since each cluster is active only once during the period, the end-to-end delay of a given flow may span over several periods when there are the flows with opposite direction. The scheduling tool enables system designers to efficiently configure all required parameters of the IEEE 802.15.4/ZigBee beacon-enabled cluster-tree WSNs in the network design time.



# International Journal of Innovative Research in Computer and Communication Engineering

(An ISO 3297: 2007 Certified Organization)

Vol. 3, Issue 8, August 2015

It is unrealistic to support hard real-time communications in a WSN due to communication errors resulting from the unreliable and time-varying characteristics of wireless channels. To increase the reliability of data transmission, the acknowledgment and retransmission mechanisms are employed. On the other hand, each retransmission also increases the energy consumption and the communication delay such that a trade-off must be found using the simulation prior to the network deployment.

Plug-n-Play Smart Sensor Based on Web Service [7] present an implementation of a plug-n-play Web sensor based on Web service approach utilizing open source software and adopting low cost hardware architecture. After an introduction to the Web service technology, the problem of the dynamic services and one solution will be dealt. In this way, if it inserted a new sensor in a network, its services are automatically published without network reconfiguration. The sensor is presented in the framework of a hierarchical distributed system for metrological application of monitoring. Particular attention is devoted to synchronization problems among all devices that compose the proposed distributed system accounting characteristics of main synchronization standards. Measurement results are made available as Web services so that all users can build up their own applications. The particular metrological application chosen to show some preliminary results of distributed monitoring network is the monitoring of root mean square (RMS) values in three-phase power networks. A proper synchronization protocol was adopted in order to synchronize to different hardware sections of the sensor performing measurement.

In this an implementation of a Web sensor based on Web service approach utilizing open source software and adopting low cost hardware architecture. The problem of the dynamic services and one solution has been deal [7]. The sensor has been presented in the framework of a hierarchical distributed system for metrological application of monitoring. Particular attention has been devoted to synchronization problems among all devices that compose the proposed distributed system accounting characteristics of main synchronization standards. The particular metrological application chosen has been the monitoring of RMS values in three-phase power networks. A proper synchronization protocol has been adopted in order to synchronize of the different hardware sections of the sensor performing measurement.

A ZigBee-Based Wireless Sensor Network Node for Ultraviolet Detection of Flame [8] describes a ZigBee-based wireless sensor network node for the ultraviolet (UV) detection of flame. The sensor node is composed of a ZnSSe UV photo detector, a current-sensitive front end including a high-gain current-to-voltage amplifier with 120 dB and a logarithm converter, and a transceiver operated at a 2.4-GHz industrial, scientific, and medical band. A passive photo detector is designed to have a cut-off at 360 nm and convert the UV emission of flame into Pico amperes. Including mixed signal processing and ZigBee transmission, the speed of flame detection is as fast as 70 Ms. The sensor node consumes only an average of 2.3 mW from a 3.3-V supply. The performance of a prototype sensor node was verified when the luminous flame was imaged onto the sensor node with different angles ranging from  $-30^\circ$  to  $30^\circ$  and distances of 0.1, 0.2, and 0.3 m enabling effective fire safety applications.

It is a low-cost and low-power ZigBee-based WSN node for the UV detection of flame, contributing to the fire safety protection industry. A prototype node includes a tiny passive ZnSSe UV photo detector; a current sensitive front end, including a total of 174-dB gain from the combination of a high-gain current-to-voltage amplifier and a logarithm converter with 50-dB scales; and a low-power consumption 2.4-GHz ZigBee transceiver.

Monitoring in Industrial Systems Using Wireless Sensor Network with Dynamic Power Management [9] proposes a digital system for energy usage evaluation, condition monitoring, diagnosis, and supervisory control for electric systems applying wireless sensor networks (WSNs) with dynamic power management (DPM). The system is based on two hardware topologies responsible for signal acquisition, processing, and transmission: intelligent sensor modules (ISMs) and remote data acquisition units (RDAUs). The gateway function of the wired network is carried out by remote servers (RSs) based on the *Soekris* architecture, which is responsible for receiving the data collected and transmitting it to the supervisory controller (SC). To extend the WSN lifetime, sensor nodes implement a DPM protocol. The basic characteristics of the presented system are the following: 1) Easy implementation, 2) low-cost implementation, 3) Easy implementation of redundant routines (security), 4) portability/versatility and, 5) Extended network lifetime.



# International Journal of Innovative Research in Computer and Communication Engineering

(An ISO 3297: 2007 Certified Organization)

Vol. 3, Issue 8, August 2015

Zigbee Based WSN with IP Connectivity [10] proposes new addressing mechanisms to create virtual IP and WSN addresses as part of this integration. Wireless sensor network (WSN) consists of distributed sensor nodes in the remote locations and are used to measure the sensor data in remote locations. Each node of WSN consists of a wireless microcontroller interfaced with sensors.

The user is confronted with independently working and diverse electronic devices like television, PDAs, laptops etc. Middleware is required to glue all these heterogeneous devices. This also integrates WSN with IP to cater the real world requirements and enables the electronic device of the IP- based WSN to access the other device of the same or different network. TCP / IP stack is not suitable to be ported into the memory of WSN node. It occupies more memory and causes more overhead to the WSN [10]. There are two basic approaches towards the realization of IP based WSN viz., gateway based approach and virtual gateway approach. The hardware is employed with one coordinator, three routers and one handheld device that integrate IP and WSN. A new network based on wireless micro controllers to integrate IP and WSN is proposed.

### III. PROBLEM DEFINITION

Automatic control panel are available in industries for monitoring and controlling the parameters of machines and hence final product. But most of the control panels in industries are wire panels and machines are controlled and monitor by the control room operator using wire network. The wires are moving through conducts, sometimes inside walls and sometimes underground also. So breakdown maintenance of these wires are difficult task in industries. As these wires are not open so it is difficult to locate the fault. And even after locating the fault it takes time to repair them. The second disadvantages of this method are operator console cannot move from one room to another. Every time operator has to go to particular room to monitor and control the operation.

In the proposed method we overcome the drawback present in existing system by using wireless sensor network. We are designed a system by using Network chip, FPGA and wireless and wired peripherals which supports different features and algorithms for the development of automation systems. We can use different wireless technology called Zigbee, Wi-Fi, GPRS etc... Many open source libraries and tools are available for FPGA wireless sensor network development and controlling. We can also monitor and control the wireless sensor network remotely using internet and webserver.

### IV. ARCHITECTURE

We design and implement a reconfigurable smart sensor interface device that integrates data collection, data processing, and wired or wireless transmission together. The device can be widely used in many application areas of the IoT and WSN to collect various kinds of sensor data in real time. We program IP core module of IEEE1451.2 corresponding protocol in its FPGA. Therefore, our interface device can automatically discover sensors connected to it, and to collect multiple sets of sensor data intelligently, and serially with high-speed. FPGA is core controller of the interface device. It is used to control data acquisition, processing, and transmission intelligently, and make some pre-processing work for the collected data [11]. The driver of chips on the interface device is also programmed inside the FPGA. In terms of data transmission, our design can achieve wired communication through Universal Serial Bus (USB) interface and wireless communication through Zigbee module. Therefore, we can choose different transmission mode of the device in different industrial application environments.

### V. IMPLEMENTATION

#### A. The Introduction of the Hardware Architecture

The overall structure of smart sensor interface consists of FPGA, sensors and peripheral circuit, communication circuit for turning USB to serial port, power supply of 1.8 and 3.3 V. The hardware system can also send and receive data besides the basic sensor data acquisition. It can send data to the control centre via USB serial port or Zigbee wireless module. Zigbee wireless communication module can be connected with the board through the mini-USB interface or the extensible GPIO interface on the device. It can be used as wireless data transceiver node when the main

# International Journal of Innovative Research in Computer and Communication Engineering

(An ISO 3297: 2007 Certified Organization)

Vol. 3, Issue 8, August 2015

controller receives trial or executive instructions [12]. After the data control centre finishes further processing for the received data, it needs to feedback related actions to sensor interface device. Data communication function can also control the running status of corresponding peripheral device.

## B. IEEE 1451

The IEEE 1451 set of standards define an architecture which allows sensor and actuator nodes to connect into a live distributed control network, in a true ‘plug and play fashion. The standard itself is composed of four parts: IEEE 1451.1 through to IEEE 1451.4. Although the extent of each part is well defined, currently only the first two parts (IEEE 1451.1 and IEEE 1451.2) exist as fully released, balloted standards. The fig.1. Shows the IEEE 1451 smart transducer concept. The advantages of IEEE 1451 are: Comprehensive enough to cover nearly all sensors and actuators in use today, many operating modes, extensive units, linearization and calibration options, multiple timing and data block size constraints handled, compatible with most wired and wireless sensor buses and networks, efficient binary protocol, standard is 400+ pages for basic part, over 1500 page total.

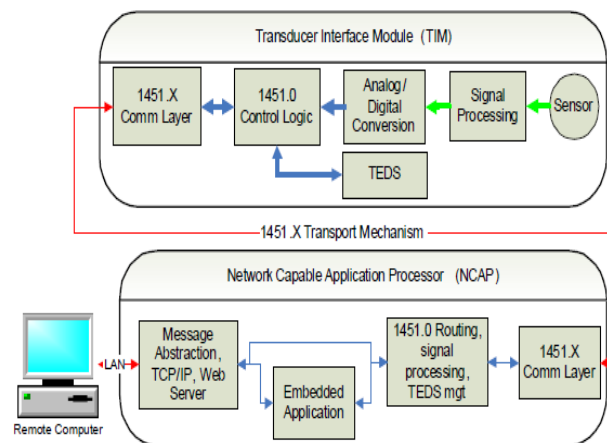

Fig.1. IEEE 1451 smart transducer concept.

Specialized networks can handle only a limited number of sensor types or uses non-compact format where IEEE 1451 is much superior at the sensor end. Most applications require individualized displays or graphical user interfaces - 1451 is a fixed format and poorly suited at the user end. Network oriented applications prefer XML or similar formats which are convenient, but are too verbose at the sensor end but the IEEE 1451 at the sensor end (Sensor Fusion level 0) combined with translators is the best solution. Many abbreviations are used throughout the description of IEEE 1451.2. Some of the more prominent ones are introduced here, and their underlying concepts are briefly outlined:

### STIM- Smart Transducer Interface Module

A STIM can range in complexity from a simple single channel sensor, or actuator, to a product supporting multiple channels of transducers. A transducer channel is denoted ‘smart’ in this context because: It is described by a machine-readable TEDS. The control and data associated with the channel are digital. Triggering, status and control are provided to support the proper functioning of the channel. Fig. 2. Shows the STIM overall design structure diagram and the Fig. 3. Shows the STIM state machine design structure diagram.

### TII - Transducer Independent Interface.

The TII is a 10-wire serial I/O bus that defines:

- A triggering function that triggers reading /writing from/to a transducer.
- A bit transfer methodology
- A byte-write data-transport protocol (NCAP to STIM)

# International Journal of Innovative Research in Computer and Communication Engineering

(An ISO 3297: 2007 Certified Organization)

Vol. 3, Issue 8, August 2015

- A byte-read data-transport protocol (STIM to NCAP)
- Data transport frames

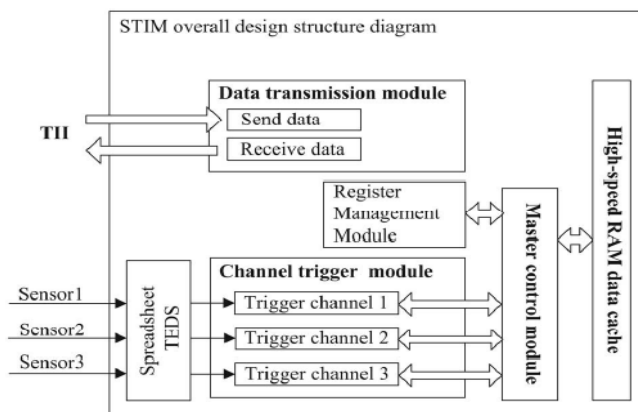

Fig. 2. STIM overall design structure diagram

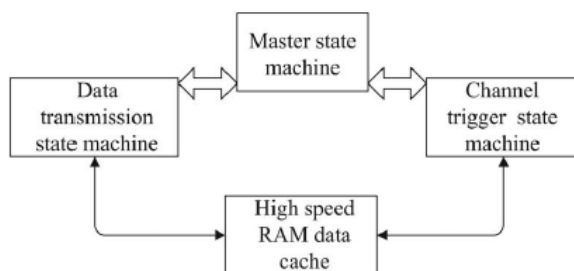

Fig. 3. STIM state machine design structure diagram.

TEDS - Transducer Electronic Data Sheet.

The TEDS is a data sheet written in electronic format that describes the STIM and the transducers associated with it. It includes data such as manufacturer's name, type of transducer, serial number, etc. By definition, the TEDS must remain with the STIM for the duration of the STIM's lifetime. Fig. 5. Shows the TEDS state machine's schematic

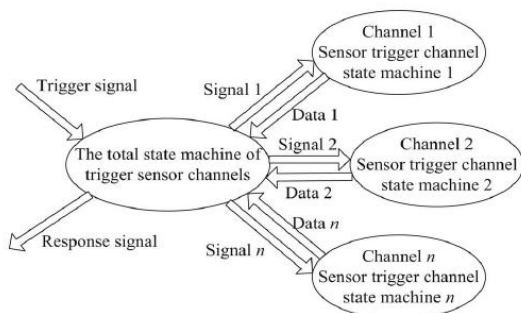

diagram.

Fig. 4. Data reading channel state machine.

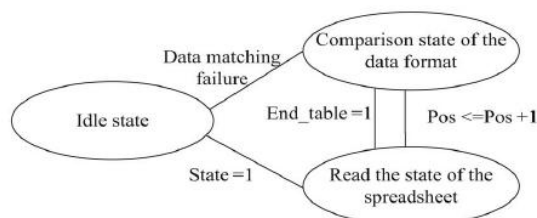

Fig. 5. TEDS state machine's schematic diagram.

# International Journal of Innovative Research in Computer and Communication Engineering

(An ISO 3297: 2007 Certified Organization)

Vol. 3, Issue 8, August 2015

Initial state of the system is defined by its idle state. When the start signal ranges from state 0 to 1, the state will jump from the idle state to the reading state of spreadsheet. Data can be saved to the register through serial and parallel transformation. The state updated to the contrast state of data format after reading a set of data. At the same time, the status flag pos will automatically add 1 and prepares for contrasting the next message. At this point, the internal sensor data information that has been defined at the initialization time will compare it with the data read from the external. Otherwise, the contrast state of data format will return to idle state. If comparative success, it will automatically start the next data comparison.

In our design, the sensor channel trigger state machine is assigned with a specific ID number. At the same time, the ID also represents the priority of data collection. There are numerous methods to define priority, such as sensor conversion rate data length etc. Data length is used as the standard to set priority. When data has different length, the "short data priority" principle can effectively guarantee the overall time consumption of the whole data collection, so as to enhance real-time character of acquisition system. The family of IEEE 1451 standard interfaces will provide the following benefits:

- enable self-identification of transducers
- facilitate self-configuration
- maintain long term self-documentation
- make for easy transducer upgrade and maintenance
- Increase data and system reliability allow transducers to be calibrated remotely.

## C. Verilog HDL Design

Verilog Hardware Description Language design of the system includes two parts. It reflects the difference between reconfigurable smart sensor interface device and general data acquisition card, which has a great effect in intelligently collecting sensor data. The other part is programming the interface driver based on Verilog hardware description language. It mainly covers programming of each hardware chip driver and sensor driver on the device.

## VI. APPLICATION

### A. Software and Hardware Design

1) Hardware Design: The core module of this system is FPGA -based reconfigurable smart sensor interface device designed by ourselves. It can well meet the requirements mentioned above. Here are the main solutions: Firstly, we suggest that temperature sensor, pressure and humidity sensor should be used to collect required data; Secondly, Zigbee wireless module connected to the device is adopted for sending and receiving data. After combination of the above hardware, the system gains low cost, low power consumption, small volume, and other characteristics. Compared with the general monitoring system using large equipment, it is more flexible and convenient. RS232 communication protocol is adopted in design to support the TII interface. The feature of RS232 is completely in accordance with the TII. Function of the interface owns good versatility and usability. Multi node monitoring can be realized through Zigbee wireless module.

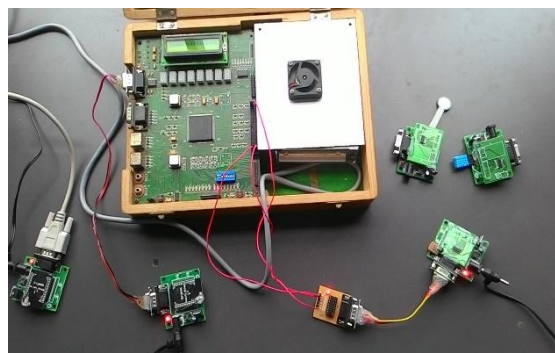

Fig. 6. Hardware physical map.



# International Journal of Innovative Research in Computer and Communication Engineering

(An ISO 3297: 2007 Certified Organization)

Vol. 3, Issue 8, August 2015

Fig. 6. Shows the Monitoring hardware physical map. It can be used for various application like office automation, home automation industry automation, agricultural farm monitoring and data collection and operation purpose etc...

2) Software Design: Software design of monitoring system also includes two parts. Firstly, the Program uses the hardware description language based on FPGA, to control different sensor data acquisition and the last communication processing. Secondly, because the sensor data is defined in the spreadsheet (TEDS), we just simply modify the corresponding sensor data format in spreadsheet according to different application systems.

In our system, the sensor channel trigger state machine is assigned with a specific ID number. At the same time, the ID also represents the priority of data collection. After a sensor is connected to the system, the system will automatically search for data format of the equipment through a predefined physical interface and the corresponding relation of the spreadsheet. Then, the system completes standard conversion of the data format automatically. Finally, the transformed data are presented on the serial port terminal. The resource utilization summary and power analysis is shown in Table I.

TABLE I  
Resource utilization and power analysis

No. of Slices LUTs (Out of 9112)	No. of IO (Out of 232)	No of BUFG/ BUFGCTRLs (Out of 16)	Delay (ns)	Power (mW)
85	7	1	2.934	20

TABLE II  
Specific Sensor Type

Type	Name
Temperature sensor	LM35
Pressure Sensor	FSR
Humidity Sensor	AOSONG DHT11

Through actual test, we learn that the designed system can immediately collect sensor data when it is connected to power. The system has good compatibility and expansibility for different types of sensors. We have successfully tested different types of sensors on this system. Table II is the specific sensor types that we have tested.

## VII. CONCLUSION

This paper describes the design and implementation of network chip for wireless and wired peripherals with serial communication is described here. The specified system can collect sensor data intelligently. It was designed based on IEEE1451 protocol by combining with FPGA and the application of wireless communication. It is very suitable for real-time and effective requirements of the high-speed data acquisition systems. The application of FPGA greatly simplifies the design of peripheral circuit, and makes the whole system more flexible and extensible. The application of IEEE1451 protocol enables the system to collect sensor data intelligently. Different types of sensors can be used as long as they are connected to the system. Main design method of network on chip for wireless and wired peripherals with serial communication is described in this paper. Finally, by taking real time

Monitoring of temperature, pressure and humidity in atmosphere as an example, we verified that the system achieved good effects in practical application. Nevertheless, many interesting directions are remaining for further



# International Journal of Innovative Research in Computer and Communication Engineering

(An ISO 3297: 2007 Certified Organization)

Vol. 3, Issue 8, August 2015

researches. For example, the IEEE1451 protocol can be perfected and the function of spreadsheet should be expanded. It will have a broad space for development in the area of WSN in IoT environment.

## REFERENCES

1. Qingping Chi, Hairong Yan, Chuan Zhang, Zhibo Pang, and Li Da Xu, "A Reconfigurable Smart Sensor Interface for Industrial WSN in IOT Environment", IEEE Transactions On Industrial Informatics, Vol. 10, No. 2, May 2014
2. M. T.Lazarescu, "Design of a WSN platform for long-term environmental monitoring for IoT applications," IEEE J. Emerg. Sel. Topics Circuits Syst., vol. 3, no. 1, pp. 45–54, Mar. 2013.
3. R. Dafali, J. Diguët, and J. Creput, "Self-adaptive network-on-chip interface," IEEE Embedded Syst. Lett., vol. 5, no. 4, pp. 73–76, Dec. 2013.
4. Z. Pang et al., "An RTOS-based architecture for industrial wireless sensor network stacks with multi-processor support," in Proc. Ind. Technol. (ICIT), 2013, pp. 1216–1221.
5. S. Li, L. Da Xu, and X. Wang, "Compressed sensing signal and data acquisition in wireless sensor networks and internet of things," IEEE Trans. Ind. Informat., vol. 9, no. 4, pp. 2177–2186, Nov. 2013.
6. Z. Hanzalek and P. Jurcik, "Energy efficient scheduling for cluster-tree wireless sensor networks with time-bounded data flows: Application to IEEE 802.15. 4/ZigBee," IEEE Trans. Ind. Informat., vol. 6, no. 3, pp. 438–450, Aug. 2010.
7. F. Ciancetta et al., "Plug-n-play smart sensor based on web service," IEEE Sensors J., vol. 7, no. 5, pp. 882–889, May 2007.
8. P. Cheong et al., "A ZigBee-based wireless sensor network node for ultraviolet detection of flame," IEEE Trans. Ind. Electron., vol. 58, no. 11, pp. 5271–5277, Nov. 2011.
9. F. Salvadori et al., "Monitoring in industrial systems using wireless sensor network with dynamic power management," IEEE Trans. Instrum. Meas., vol. 58, no. 9, pp. 3104–3111, Sep. 2009.
10. Alaparathi Narmada and ParvataneniSudhakara Rao, "Zigbee Based WSN with IP Connectivity", 2012 Fourth International Conference on Computational Intelligence, Modelling and Simulation.
11. E. J. Bueno et al., "A DSP-and FPGA-based industrial control with high speed communication interfaces for grid converters applied to distributed power generation systems," IEEE Trans. Ind. Electron., vol. 56, no. 3, pp. 654–669, Mar. 2009.
12. [3] P. Cheong et al., "A ZigBee-based wireless sensor network node for ultraviolet detection of flame," IEEE Trans. Ind. Electron., vol. 58, no. 11, pp. 5271–5277, Nov. 2011.

## BIOGRAPHY

**Anjali Devan P** is a PG (Mtech, VLSI & Embedded Systems) student in the Electronics and Communication Engineering Department, Sree Narayana Gurukulam College of Engineering, Kadayiruppu, Ernakulam, India. She received Bachelor of Engineering (BE) degree in 2013 from Srinivasan Engineering College, Perambalur, Tamil Nadu, India. Her research interests are VLSI, Embedded Systems etc.