



Auto-Theft Prevention System for Underwater Sensor Using Labview

K.Saravanakumar, J.Logeshwaran

Assistant Professor, Dept. of ECE, Mahendra College of Engineering, Salem, India

Assistant Professor, Dept. of ECE, Mahendra College of Engineering, Salem, India

ABSTRACT: This paper is concerned about the design and implementation of a system which is used to identify and prevent water theft in urban residents and commercial establishments where drinking water is provided at a fixed rate. The proposed idea is to develop a LabVIEW based remote water monitoring and theft prevention system by recording the flow rate at the consumer end. It consists of a microcontroller that continuously monitors and records the flow rate of water using a flow sensor and to transmit the same to water supply board. It is also provided with a solenoid valve to supply water to the consumers. The microcontroller and driver circuit combination is used to control the solenoid valve. The valve will turn on/off automatically by the central processing station PC to stop the water supply whenever the flow rate exceeds the predefined limit. Two flow sensors are used in the pipeline which supplies water to the consumer. When the rate of flow between these two flow sensors differs, the solenoid valve closes automatically and the water theft is indicated to the PC present at the water supply board. The address of the consumer will be displayed in the PC with penalty for theft. Thus water theft can be identified and prevented, enhancing equal share of water to the public.

KEYWORDS: Flow Sensor, solenoid Device Control, Lab VIEW, Water Theft.

I. INTRODUCTION

For the first time in history, half of the world's population is living in cities. By the year 2025, it is estimated that more than two-thirds will be urban dwellers. While the fastest growth of cities is taking place in the developing world, urbanization is a global phenomenon, closely related to environmental issues. The rapid growth of urban centres will place tremendous stress on the environment and pose formidable problems of social and institutional change, infrastructure development, and pollution control.

Water is an essential natural resource for human existence. Water will be one of the key resources for sustainable urban development. It is needed for virtually every human endeavour for household use, agriculture, industry, leisure and water also has an important ecosystem function. Provision of sufficient water and preventing pollution, however, are formidable tasks. It is needed in every industrial and natural process, for example, it is used for oil refining, for liquid extraction in hydro- metallurgical processes, for cooling, for scrubbing in iron and steel industry and for several operations in food processing industries etc.,

It is necessary to adopt a new approach to design urban water supply networks, water shortages are expected in the forthcoming decades and environmental regulations for water utilization and waste- water disposal are increasingly stringent. To achieve a sustainable water supply network, new sources of water are needed to be developed, and to reduce environmental pollution. The price of water is increasing, so less water must be wasted and actions must be taken to prevent pipeline leakage and water theft. Shutting down the supply service to fix leaks is less tolerated by consumers. A sustainable water supply network must monitor the freshwater consumption rate and the waste-water generation rate. Many of the urban water supply networks in face problems related to population increase, water scarcity, environmental pollution and water theft.

The principle cause of water scarcity is the growth in demand. Water is taken from remote areas to satisfy the needs of urban areas. Another reason for water scarcity is climate change precipitation patterns have changed, rivers have decreased their flow, lakes are drying up, and aquifers are being emptied. In developing countries many governments are corrupt and poor and they respond to these problems with frequently changing policies.

Water demand exceeds supply, and household and industrial water supplies are prioritised over other uses, which



International Journal of Innovative Research in Computer and Communication Engineering

(An ISO 3297: 2007 Certified Organization)

Vol. 4, Issue 2, February 2016

leads to water stress. Potable water has a price in the market; water often becomes a business for private companies, which earn a profit by putting a higher price on water, which imposes a barrier for lower-income people. The Millennium Development Goals propose the changes required.

In Water for Urban Areas, leading experts from four continents offer unique insights into varied issues of urban water management. In case studies from the South as well as the North, the authors seek solutions and identify strategies for sustainable management of water resources for burgeoning mega-cities. They consider both technical issues, such as wastewater reuse, and management issues, including financial mechanisms for improved water sector management. In advanced economies, the problems are about optimising existing supply networks. These economies have usually had continuing evolution, which allowed them to construct infrastructure to supply water to people. The European Union has developed a set of rules and policies to overcome expected future problems.

A. *Optimizing the water supply network*

The yield of a system can be measured by either its value or its net benefit. For a water supply system, the true value or the net benefit is a reliable water supply service having adequate quantity and good quality of the product. For example, if the existing water supply of a city needs to be extended to supply a new municipality, the impact of the new branch of the system must be designed to supply the new needs, while maintaining supply to the old system.

B. *Single-objective optimization*

The design of a system is governed by multiple criteria, one being cost. If the benefit is fixed, the least cost design results in maximum benefit. However, the least cost approach normally results in a minimum capacity for a water supply network. A minimum cost model usually searches for the least cost solution (in pipe sizes), while satisfying the hydraulic constraints such as required output pressures, maximum pipe flow rate and pipe flow velocities. The cost is a function of pipe diameters; therefore the optimization problem consists of finding a minimum cost solution by optimising pipe sizes to provide the minimum acceptable capacity.

C. *Multi-objective optimization*

However, according to the authors of the paper entitled, "Method for optimizing design and rehabilitation of water distribution systems", "the least capacity is not a desirable solution to a sustainable water supply network in a long term, due to the uncertainty of the future demand". It is preferable to provide extra pipe capacity to cope with unexpected demand growth and with water outages. The problem changes from a single objective optimization problem (minimizing cost), to a multi-objective optimization problem (minimizing cost and maximizing flow capacity).

D. *Weighted sum method*

To solve a multi-objective optimization problem, it is necessary to convert the problem into a single objective optimization problem, by using adjustments, such as a weighted sum of objectives, or a ϵ -constraint method. The weighted sum approach gives a certain weight to the different objectives, and then factors in all these weights to form a single objective function that can be solved by single factor optimization. This method is not entirely satisfactory, because the weights cannot be correctly chosen, so this approach cannot find the optimal solution for all the original objectives.

E. *The Constraint Method*

The second approach (the constraint method), chooses one of the objective functions as the single objective, and the other objective functions are treated as constraints with a limited value. However, the optimal solution depends on the pre-defined constraint limits.

F. *Operational Constraints*

Returning to the cost objective function, it cannot violate any of the operational constraints. Generally this cost is dominated by the energy cost for pumping. "The operational constraints include the standards of customer service, such as the minimum delivered pressure, in addition to the physical constraints such as the maximum and the minimum water levels in storage tanks to prevent overtopping and emptying respectively."

In order to optimize the operational performance of the water supply network, at the same time as minimizing the energy costs, it is necessary to predict the consequences of different pump and valve settings on the behaviour of the network. Apart from Linear and Non-linear Programming, there are other methods and approaches to design, to manage and operate a water supply network to achieve sustainability for instance, the adoption of appropriate technology coupled with effective strategies for operation and maintenance.

These strategies must include effective management models, technical support to the householders and industries, sustainable financing mechanisms, and development of reliable supply chains. All these measures must ensure the following system working lifespan, maintenance cycle, continuity of functioning, down time for repairs, water yield and water quality. Other possible approaches to scoping models for water supply,



International Journal of Innovative Research in Computer and Communication Engineering

(An ISO 3297: 2007 Certified Organization)

Vol. 4, Issue 2, February 2016

applicable to any urban area, include the following:

- a) Sustainable Urban Drainage System.
- b) Borehole extraction.
- c) Inter-cluster groundwater flow.
- d) Canal and river extraction.
- e) Aquifer storage
- f) A more user-friendly indoor water use.

II. WATER THEFT IDENTIFICATION USING EMBEDDED TECHNOLOGY

In urban areas the water supply to residence and commercial establishments are provided at a fixed flow rate. There are incidents of excess water drawing by certain customers/users by connecting motor-pump sets to the water lines which is considered as water theft. In this existing system it is to develop an embedded based remote water monitoring and theft prevention system by recording the flow rates at the consumer/user end.

To implement this method in water supply system, each consumer end should be provided with an embedded based water flow monitoring system consisting of a microcontroller to record the flow rate using a flow sensor and to transmit the same to a remote monitoring station using wireless transmitter and it is also provided with an electrically operated solenoid valve to supply water to the consumers. The valve turns on/off by the central processing station PC to stop the water supply whenever the flow rate exceeds a predefined limit. It is developed to employ a GSM MODEM for wireless communication so that the information can be passed to many responsible officers cell phone for immediate action.

III. WATER THEFT IDENTIFICATION AND PREVENTION USING LABVIEW

Water conservation should not be considered an option any longer. Current circumstances require full attention if people hope to thrive as a civilization. If these statements sound dramatic, it is because much of the world is currently suffering due to a lack of clean water. Statistic sound the world reveal that fresh water supply is practically non-existing. That is why it is so important to seek out, find and start using all the innovative water conservation solutions and methods that are available today.

Whether people live in Australia or China or the US, it is time to wake up and take responsibility. It is easy to practice water conservation in the home, but there is more to be done. World needs help on a commercial level as well so that water waste can be controlled in such areas as agriculture and irrigation. A number of large commercial establishments and residences are committing theft of potable water distributed by the PWD in collusion with PWD employees and the local panchayats. With tanker water coming at a price, many resorts have resorted to building huge sumps under their properties to store water, even though they're not allowed to do so. These sumps are then connected to the domestic water pipeline which supplies water to the local residents. Using high-powered water pumps, they then suck out water from the domestic water pipeline and fill up their underground sumps.

It is a criminal use of the water distribution system. Day by day the number of resorts is increasing and local residents are facing a severe shortage. Resorts have huge sumps with capacities of one lakh litres, three lakh litres where they store water and all that water is sucked out from the water distribution pipeline, urging the government to take action and also to penalize PWD staffers who are in collusion with the resorts. The problem of water theft has been going on for years, both for residents and hoteliers. Dozens of water tankers ferrying water to resorts are a common sight every day. The state and the central government had proposed a number of water treatment plants to ease the problem of water shortage. Every few days a water pipeline is ruptured, leading to that area going dry at times for days at a stretch. The reason, according to the contractors, is the haphazard manner in which the water pipeline network has been laid.

IV. WATER THEFT IDENTIFICATION SYSTEM

A water theft identification system which is controlled by PIC microcontroller and monitored by LabVIEW software is designed. There are certain residences and commercial establishments which consume excess water that is supplied by the water supply board through government pipelines. This paper deals about the identification of water

International Journal of Innovative Research in Computer and Communication Engineering

(An ISO 3297: 2007 Certified Organization)

Vol. 4, Issue 2, February 2016

theft by measuring the flow rate of water through the pipeline.

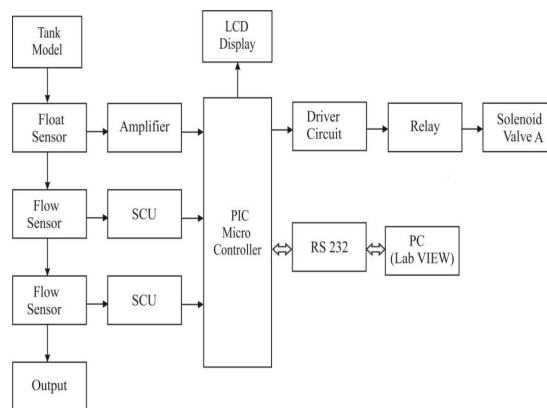

Fig:1.1 Block diagram of water theft identification and prevention system

There is a float sensor placed inside the tank which determines the level of water available in the tank. Two flow sensors are used to record the flow rate of water through the pipeline. Water from the tank is fed to each resident through a common pipeline. Each resident has their own pipeline that is connected to the common line to fetch water. Flow sensors are placed in the common pipeline near the branch pipe of every house. When water is being stolen between one flow sensor and the other, the flow rate of water recorded by the second flow sensor will be lesser when compared to the first one. When this change in flow rate occurs, the solenoid valve will be closed automatically and the water supply for the resident is immediately cut off.

The Signal Conditioning Unit (SCU) accepts the input signal from the analog sensor and gives the conditioned output of 0-5V DC corresponding to the entire range of parameters. The signals from the SCU are given to the PIC microcontroller. The microcontroller instructs the solenoid valve to close in case there is any excess water flow in the pipeline. A solenoid valve cannot be operated in a normal 0-5V power range, therefore a driver circuit with relay is used to operate the solenoid valve.

A. Level measurement using float

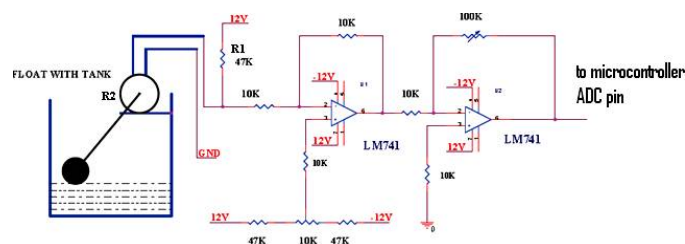

Fig 1.2 Schematic for Level measurement using float

Float is a type of transducer which is used to measure the water level in the tank. Float will be varied depending upon the water level which in turn varies the resistance value. The resistance value is directly proportional to the output. This output is given to the inverting amplifier LM 741. Amplifier inverts and amplifies the output signal. Inverting amplifier inverts from 0 to 180 degree. So the output will be in negative state. This negative signal voltage is given to next stage of gain amplifier LM 741. This is constructed by another operational amplifier so the output will be positive signal. In the gain amplifier the variable resistor is connected in the feedback path, by adjusting the resistor, the desired gain can be obtained. Then the final voltage is given to ADC in order to convert the analog signal to digital signal. The corresponding digital signal is given to the microcontroller for further process. ADC value will increase if the level is increased. Water level can be measured only with the help of any controller or processor.

International Journal of Innovative Research in Computer and Communication Engineering

(An ISO 3297: 2007 Certified Organization)

Vol. 4, Issue 2, February 2016

B. FLOW MEASUREMENT USING FLOW SENSOR

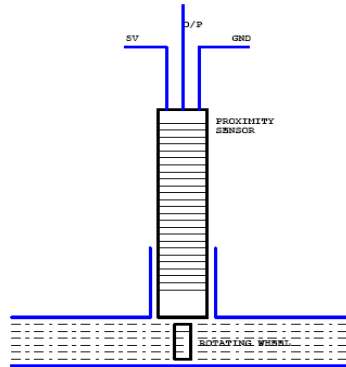

Fig 1.3 Schematic for flow measurement using flow sensor

Here the rotating wheel is fixed inside the pipe where the water flow has to be measured. When the water is flowing with pressure, the wheel rotates. The wheel rotation is monitored by the proximity sensor. Rotating wheel is nothing but a Plus shaped magnet. The proximity sensor delivers the output in the form of pulse when it detects the magnetic flux. This is given to microcontroller which counts the pulse which is equal to rate of water flow in the pipe. This circuit is mainly used for monitoring the water flow and maintains the set level using control circuit.

C. Signal Conditioning Unit(SCU)

The signal conditioning unit accepts input signals from the analog sensors and gives a conditioned output of 0-5V DC corresponding to the entire range of each parameter. This unit also accepts the digital sensor inputs and gives outputs in 10 bit binary with a positive logic level of +5V. The calibration voltages (0, 2.5 and 5V) and the health bits are also generated in this unit.

Microcontrollers provide real time control by processing analog signals obtained from the system. A suitable isolation interface needs to be designed for interaction between the control circuit and high voltage hardware. A signal conditioning unit provides necessary interface between a high power grid inverter and a low voltage controller unit.

V. RESULT AND DISCUSSIONS

The simulation results for the water theft identification system provides the ultimate result of the process. The entire control logic of the process can be implemented using LabVIEW block diagram approach and all the changes that are made in the block diagram will be reflected in the front panel.

A. Block diagram of water theft identification system

The LabVIEW block diagram for water theft identification system is shown in the fig 1.4.

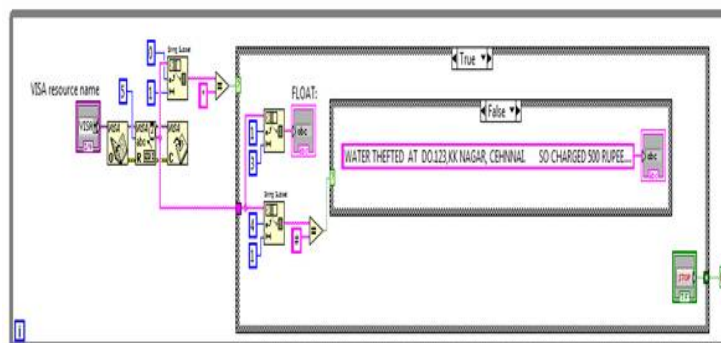

Fig 1.5 Block diagram of water theft identification system

International Journal of Innovative Research in Computer and Communication Engineering

(An ISO 3297: 2007 Certified Organization)

Vol. 4, Issue 2, February 2016

The VISA resource name is the name of the hardware from which the input is taken. The digital signal is read by the block VISA read. A time limit is set in the string subset. This is the time taken by the system to indicate status of the system in the front panel.

The comparison tool is used to compare the values from the two flow sensors. Constants are used to denote the time required to display the status of the system and the flow rate that is measured in two flow sensors. When the water level in the tank is high, the float sensor will enable logic1, when the water level in the tank is low, logic 0 is enabled. String is used to display the level of the tank in the front panel. While loop is used here for running the code while the desired condition is true. Two case structures are used, true case is executed if the flow rate values in both the flow sensors are equal. False case is executed if the flow rate recorded in the second flow sensor is greater than the first flow sensor. The front panel will display the status as "NO THEFT", if there is no difference in the values recorded in both the sensors. The front panel will display the address of the consumer who has attempted to steal the water in case any decrease in flow rate in the second flow sensor.

B. Block diagram of water theft identification system



Fig 1.6 Front panel of proposed system under critical condition

When there is a variation in the water flow rate between the two sensors, the system detects the change in flow. This will be indicated to the water supply board. The address of the resident will be displayed in the PC that is placed in the water supply board. Penalty for the theft will also be displayed in the front panel.

VI. CONCLUSION

The automated water theft identification system implemented into the water distribution network ensures the update of the refurbished water supply urban utilities; it offers new ways of monitoring and optimized exploitation of the water resources in commercial establishments. And this urban water supply system is based on PIC Microcontroller. It is responsible for all the controlling actions. At the same time, the use of LabVIEW software makes this system more coherent and concise.

REFERENCES

- [1] Eswaran.P and Aswin Kumar "Conceptual Design and Development of Water Monitoring System for Multiple Family Residential Buildings" International Journal of Advanced Computer Research, vol.2, pp.2277-7970.
- [2] S. Leirens,C.Zamora, R.R Negenborn, and B.De Schutter "Coordination in urban water supply networks using distributed model predictive control". Proceeding of the 2010 American Control Conference, Baltimore, Maryland, pp.3957-3962, 2010.
- [3] Lingjuan Wu, Jennifer Trezzo, Diba Mirza, Paul Roberts, Jules Jaffe, Yangyuan Wang, Fellow and Ryan Kastner IEEE Members. "Designing an Adaptive Acoustic Modem for Underwater Sensor Networks".
- [4] K. Veeranna Reddy, Y.Tirmala Babu, "A Study on auto theft prevention using GSM", International Journal of Engineering Trends and Technology, vol.2, pp.60-64, 2011.
- [5] Catherine Zamora and Juan Manuer Giraldo " Model predictive control of water transportation networks".vol.34, pp.316-321,2008.
- [6] Zulhani Rasin, Mohd Rizal Abdullah "Water Quality Monitoring System Using Zigbee based Wireless Sensor Networks". International Journal of Engineering Trends and Technology, IJET-IJENS, VOL.09.
- [7] Aina Hu, Huanhuan Wang "Design of WSN-Based Remote Monitoring System for Environmental Parameters in Substation". International Journal of Smart Grid and Clean Energy.
- [8] Trupti Patil and R.Anju Ranjani "Design of Monitoring System for Water Supply for Metropolitan City Using Embedded Technology".