



International Journal of Innovative Research in Computer and Communication Engineering

(A High Impact Factor, Monthly, Peer Reviewed Journal)

Website: www.ijircce.com

Vol. 8, Issue 3, March 2020

Intelligent Traffic Management and Pollution Control for Vehicles Using IOT

M.Suganya¹, D.Preethika², R.Priyadharshini³, A.Sandhiya⁴, V.Santhiya⁵

Assistant Professor, Department of ECE, Gnanamani College of Technology, Namakkal, Tamil Nadu, India¹

Students, Department of ECE, Gnanamani College of Technology, Namakkal, Tamil Nadu, India^{2,3,4,5}

ABSTRACT: In the use of sensor networks in environmental monitoring, vehicle monitoring and traffic management, which are important in a smart city are discussed. The main cause of environmental pollution in most smart cities is industries and automobiles emitting poisonous gases. This implementation of a unit which senses the presence of such gases and uploads the information to a website, and also sends messages to the concerned people. The next step of this work is a vehicle monitoring unit that can be fixed in vehicles. In the case of the vehicle is produced over gas then the information will be goes to pollution department. Environmental monitoring, vehicle monitoring and traffic management come under the scope of the design of smart cities using WSNs. The next part of the work, in which, vehicles which do signal jumping are detected and penalized. Peoples whose job takes them to the sides of roads, are injured or killed by roadside collisions. This feature is very relevant to the countries like India where traffic rules are regularly violated. The density of the traffic around traffic junctions is measured and information updated in the website. An Android app is developed so that all the required information is easily available. In the United States, every year, several. This could be avoided if a warning signal could be sent to them. In this paper, we describe a IOT based alerting system which detects and tracks the Heavy traffic. Unusual trajectories of Vehicle are detected when the images of their Traffic out of that region. The system promptly sends a warning signal once a risk has been identified. The system runs on the Android smart phones, which are mounted on Vehicle or on roadside fixtures. An Android app is developed so that all the required information is easily available. The paper describes the hardware and software implementation of the prototype system.

KEYWORDS: smart cities, Internet Of Things, Wireless sensor networks, Traffic management, vehicle monitoring technology.

I. INTRODUCTION

Wireless sensor network (WSNs) is an integral part to implement the concept of Internet of Things (IoT), which has affected all the aspects of our life. The concept of IoT has led to the design and development of connected devices, which can perform the functions of sensing, monitoring and actuation. One important application area of IoT is smart cities. Many cities of the world are rapidly introducing sensor based connected networks towards this goal. The Internet of Things (IoT) is the network of physical device, vehicles, home appliances and other items embedded with electronics, software, sensors, actuators, and connectivity which enable these objects to connect and exchange data. The propose an IoT based intelligent traffic management and control for vehicles, which integrates in-vehicle environmental monitoring and emergency management. The rest of the paper is structured as follows: First, presents the typical application Scenario and requirement analysis. Next, describes the overall system design including the system architecture and design flow. Detailed subsystem design and demo system setup are introduced in that following process. It is well known that vehicle errors caused by drivers are the main cause, or most accidents and appropriate collision avoidance system. This may be accomplished by giving suitable warning to the traffic management providing automatic support to longitudinal or lateral control of the vehicle Adaptive Cruise Control (ACC) is feature used in the automotive field that allows a vehicles speed (cruise) control system. This sensor is used to determine the speed and distance from the object. And further used for an identify the traffic density signal at before reach that traffic signal. The IoT for smart cities the importance of measuring the noise levels and traffic congestion as a part of a smart city



International Journal of Innovative Research in Computer and Communication Engineering

(A High Impact Factor, Monthly, Peer Reviewed Journal)

Website: www.ijircce.com

Vol. 8, Issue 3, March 2020

project. The use of GSM based alerts and notification. Use of RFID and GPS based intelligent transportation systems in IoT based smart cities. Vehicle emission is tracked by using RFID the Suggestions for real time monitoring of vehicles and detecting traffic connection the globalization .It deals with the methods to control the vehicle emission. In this work involves the design and implementation of a functional IoT application covering many aspects of a smart city. A very high end, fast processor is used for better efficiency. The processor has many GPIO pins to which more sensors may be added. In a smart city environment, many more parameters may need to be monitored. It is proposed that, in cities, control the vehicles produce the pollution and identify that traffic density of the signal.

III. EXISTING SYSTEM

In the UAE released 199.65 million tones of carbon dioxide and other greenhouse gases, with electricity and water generation contributing 64.89 million tones of greenhouse gases, road transport 44.25 million tones, and oil and gas sector 29.6 million tones. From this data, it is evident that CO₂ emissions are rising every year, and it is important to develop a system that can monitor and synthesize this data for decision makers in cheap and cost effective way. The main aim of this project is to develop prototype systems that will monitor the air and noise quality. The control unit is a hardware unit which may is placed at traffic junction. Sensors for monitoring air and noise pollution as well as gas emissions, will be interfaced wirelessly through zigbee networks or to the system delivering readings from different locations.

The functionalities of the project are listed below

1. Environmental monitoring:

- Air pollution monitoring,
- Vehicular monitoring,
- Noise pollution monitoring,
- Temperature measurement.

2. Vehicle monitoring:

- Accident detection,
- Tracking of stolen vehicle,
- Engine temperature and exhaust monitoring.

3. Traffic management:

- Measuring traffic density,
- Signal jump detection.
- Control the traffic density

A. The control unit

It monitors noise and air pollution .All information taken from the sensors is uploaded to the web and decisions are taking accordingly. If the values exceed a threshold, alerts and notifications are sent .Traffic management is also done by the control unit tandem with the ultrasonic sensors placed at the dividers of the road. It senses the density of the traffic and through the website gives the information about the level of traffic congestion. There is also a facility to detect the vehicles who jumps the red signal. Such vehicle numbers are identified and information is sent to the authorities and to the owner of the vehicle.

B .The Vehicle Unit

Its most important components are the gas and temperature sensors to measure the temperature, and the level CO₂ and other poisonous gases in the exhaust to the vehicle. The system is programmed in such a way that when a vehicle is at a junction, emission levels that are sensed are sent to the web through the control unit and if the value is above the permitted level, a message is sent to authorities and to the vehicle owner. The location of the vehicle at that instant is sensed and sent to the owner of the vehicle and to the ambulance system. The vehicle will move forward again only it gets a message from the owner to start it.

International Journal of Innovative Research in Computer and Communication Engineering

(A High Impact Factor, Monthly, Peer Reviewed Journal)

Website: www.ijircce.com

Vol. 8, Issue 3, March 2020

IV. PROPOSED SYSTEM

The real time internet of things monitoring. On board will be a micro SD card running real time operating systems in Linux or windows for internet of things (IoT) applications. At the output, the data will be logged in real time and plotted on the internet and through mobile applications to show the emissions per location. The concept of IoT has led to the design and development of connected devices, which can perform the functions of sensing, monitoring and actuation. One important application area of IoT is smart cities. Many cities of the world are rapidly introducing sensor based connected networks towards this goal. Environmental monitoring, vehicle monitoring and traffic management come under the scope of the design of smart cities using WSNs. Urban living is the keystone of modern human ecology. Cities have multiplied and expanded rapidly worldwide over the past two centuries. Cities are sources of creativity and technology, and they are the engines for economic growth. The main theme of control the pollution for vehicles.

V. BLOCK DIAGRAM

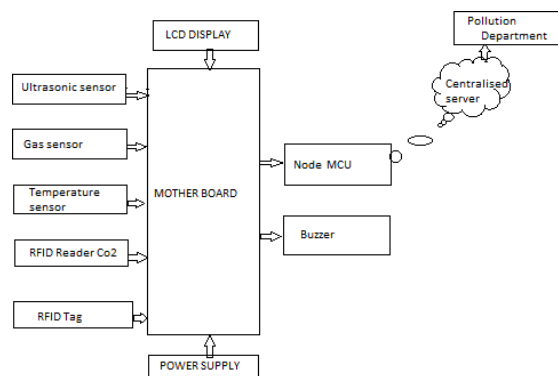

Fig 1 block diagram

Fig 1 shows the implementation of components of control the pollution for vehicles in block diagram this help used to Internet of Things.

A. The Control Unit

It has a high end embedded processor and many sensors. The control unit is the central unit from where information goes to the governing authorities through the website. The air quality can be judged from these sensors and appropriate messages can be put up in the web page associated with this application. The outputs from the sound sensor and the temperature sensor also uploaded to this web page. This unit may be placed at all traffic junctions, which is a convenient point to place it. The control unit is the central unit from where information goes to the governing authorities through the website.

The CO₂ (carbon monoxide) sensor NO₂ (Nitrogen Dioxide) and SO₂ (Sulphur dioxide) sensors are gas sensor for monitoring the quality of air around and close to the traffic junction. The air quality can be judged from these sensors and appropriate message can be put up in the web page associated with this application. The outputs from the sound sensor and the temperature sensor are also uploaded to this web page. The Xbee module is used to communicate with the vehicle unit. There is an RFID reader in this unit, which reads the RFID tag of the vehicles which stop at the junction. RFID is one card. It is used for show the card. The processing unit used is a TIVA board which has a high end Cortex-M4 processor with a clock frequency of 80MHz. It has sufficient of GPIO pins for connecting many more sensors.

International Journal of Innovative Research in Computer and Communication Engineering

(A High Impact Factor, Monthly, Peer Reviewed Journal)

Website: www.ijircce.com

Vol. 8, Issue 3, March 2020

VI. MONITORING SECTION

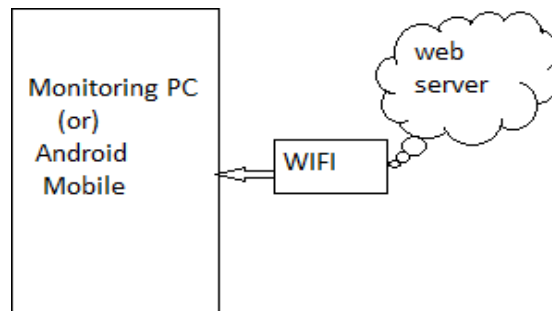

Fig 2 monitoring section A.The Vehicle Unit

Communication between the control unit and the vehicle unit is done using the Xbee module, which uses the ZigBee protocol. It has a temperature sensor for measuring engine temperature and a gas sensor for sensing the presence of poisonous gases in the engine exhaust. The GSM module sends alerts and notifications to the mobile numbers of the owner and the driver and GPS module tracks the location of the vehicle. The vehicle pollution is to be monitored, controlled and also to identify the traffic density of the traffic signal. When the pollution of vehicle is increased, then the information will be goes to the pollution department. Then the department will give some notification to authority person. If the authority person doesn't obey for the notification, then the vehicles engine will be stopped or locked.

A. Software Design:

This is an open source development environment suitable for the processors of Texas instruments. The Web server is designed with PHP as back end and HTML, CSS (Cascaded Style Sheet) and JavaScript for the front end. The controller in the control unit is connected to the internet and posts data to the web server continuously. When data is posted to a web service (using the http protocol), data validation is done and data is saved in the data server, which has an SQL database. The communication between the database and the web server is established using a PHP SQL connector. HTML is used to display the webpage and CSS is used to add styles to the website. An android app has been developed, using Android Studio for better user experience, which extracts important data from the web server and alerts the user about traffic and pollution details.

VII. FLOWCHART

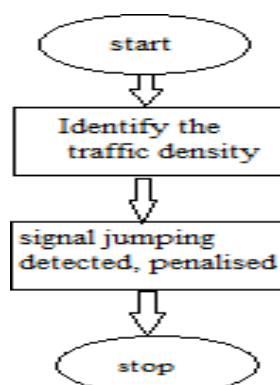

Fig 3 flowchart

International Journal of Innovative Research in Computer and Communication Engineering

(A High Impact Factor, Monthly, Peer Reviewed Journal)

Website: www.ijircce.com

Vol. 8, Issue 3, March 2020

In this system, the sensors are placed at the vehicle exhaust; monitor the hydrocarbon, carbon monoxide and nitrogen oxide value emitted from the exhaust.

The analog value received from the sensor that is processed by the control with Wi-Fi connection to the internet. The value obtained from the sensor reaches is continuously updated to LCD and cloud.

Traffic updates on the web

Junction	Traffic Status	Last Updated
Kattangal	Blocked	2018-04-17 22:40:44
Nit	Free	2018-04-23 17:02:58
Kunnamangalam	Normal	2018-04-05 30:00
Chatamangalam	Blocked	2018-04-05 23:45:25

The traffic updates on the web signaling traffic density at various locations in the city. Penalty message received by the mobile phone of the owner of a vehicle which has been detected to have jumped the red signal. The image of the Android App developed which brings all the necessary information to any inhabitant of the city. A city is a place where people with different interests, requirements and expectations live. Also, different cities have different levels of basic infrastructure. Many cities of India have been identified as candidates for being developed into 'smart'. This paper focuses on some important aspects that need attention when a comprehensive scheme for IoT based city management is envisaged.

FLOW CHART

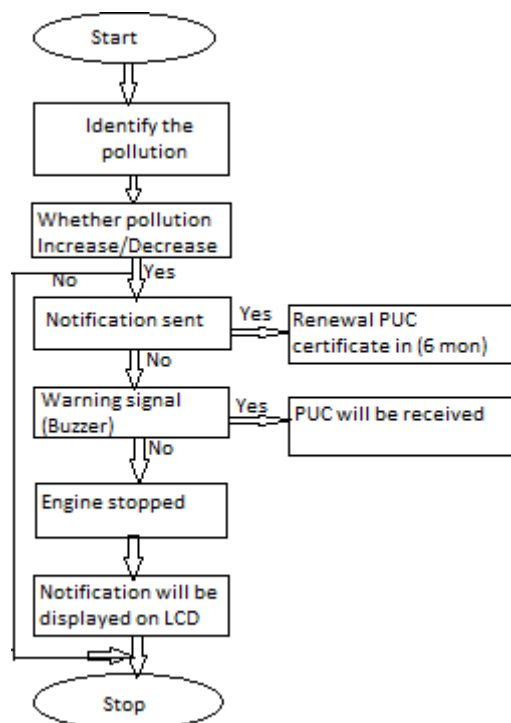

Fig 4.flowchart

International Journal of Innovative Research in Computer and Communication Engineering

(A High Impact Factor, Monthly, Peer Reviewed Journal)

Website: www.ijircce.com

Vol. 8, Issue 3, March 2020

When the value obtained from the sensor reaches the threshold limit, the controller will alert to the user through LCD and database of the vehicle owner, IoT helps the system to update the value to the cloud.

The Node MCU connected to the sensors helps to update the value obtained from the sensors to cloud when Wi-Fi is connected to the internet. The value is continuously updated to vehicle owners cloud storage. When the value reaches the threshold limit set by the government, it will indicate it to the vehicle owner. When the vehicle owner ignores that alert, the entire details will be shared with the transport office. Air quality data is collected using the MQ135 sensor.

The calibrated sensor made the analog output voltage proportional to the concentration of polluting gases in parts per Million(ppm). The data is first displayed on the LCD screen and sent to the Wi-Fi module; The Wi-Fi module transfers the measured data valve to the server via internet.

The Wi-Fi module is configured to transfer measured data application on a remote serer called “Thing speak”.

The online application provides global access to measured data via any device that has internet connection capabilities. Data collected from the sensor was converted into a string and used to update the information sent to the remote server.

VIII. RESULTS AND DISSCUSSIONS

The main theme of this paper, we control vehicle pollution and also identify traffic density of the traffic signal.

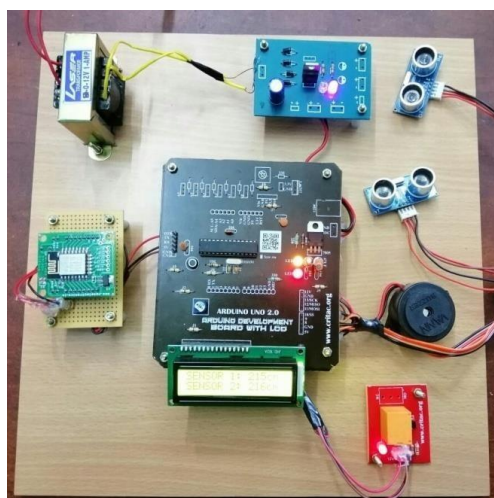

Fig 5.output image

IX. CONCLUSION

This model of extension to the betterment and development of embedded system, which can monitor the pollution vehicle and to identify the density of traffic automatically. In today’s scenario almost all countries are facing heat of energy crisis. It is nothing but energy efficient street light automation based on objective motion. Thus it will reduce number of accidents due to heavy traffic time. This paper proposes an IOT based intelligent life monitoring system for vehicles. The proposed system integrated life recognition subsystem, environmental monitoring subsystem, and alarming processing subsystem, which can judge parameters inside the vehicle and proceed corresponding activities.



International Journal of Innovative Research in Computer and Communication Engineering

(A High Impact Factor, Monthly, Peer Reviewed Journal)

Website: www.ijircce.com

Vol. 8, Issue 3, March 2020

REFERENCES

- [1] National Bureau of Statistics of People's Republic of China. China Statistical Yearbook — 2017. China Statistics Press, 2017.
- [2] Huan Wang. Two children died of heat in vehicle in Texas. China News Service.52017.[Online].Available: <http://www.chinanews.com/gj/2017/05-28/8236683.shtml>.
- [3] Lingbo Chen. Frequent Tragedy in Children's Leftovers. Guangzhou Dai ly.7 2015.[Online].Available: http://www.taizhou.com.cn/auto/2015-07/06/content_2288729_2.htm.
- [4] M.A. Jasni, F.M. Nasir. Experimental Comparison Study of the Passive Methods in Reducing Car Cabin Interior Temperature. Planetary Scientific Research Center Conference Proceedings,2012:182-186.
- [5] M Moghavvemi, C.S. Lu. Piezoelectric infrared sensor for intruder detect ion. IEEE Region 10 Technical Conference on Computers, Communications, Control and Power Engineering, 2004:656-659.
- [6] Linhong Wang. Human infrared signal recognition using single PIR detector. IEEE ernational Congress on Image and Signal Processing, 2011:2 664-2668.
- [7] S.P. Bangal1, GitePravin E2 IoT Based Vehicle Emissions Monitoring and Inspection System 2017 IJIREEICE
- [8] Chandra Mohan Reddy S 2015 Development of IoT based Vehicular Pollution Monitoring System.
- [9] Ashita Jagasia1, Sanjana Advani2 IoT based Vehicle Monitoring System using Bluetooth Technology 2017 IJIRSET .
- [10]1. Priyadarshini.J.Patil, 2Revathi.M A Survey on Intelligent System for Vehicle Emission Monitoring 2018 IJETT
- [11]D.Arunkumar, K.Ajaykanth, M.Ajithkannan, Sivasubramanian Smart Air Pollution Detection and Monitoring Using IOT International Journal of Pure and Applied Mathematics
- [12] Jagdish Nayak Round the Clock Vehicle Emission Monitoring using Io T for Smart Cities 2018 IJACSA
- [13] Bojan T.M., Kumar U.R. and Bojan V.M., December. An internet of things based intelligent transportation system IEEE International Conference on Vehicular Electronics and Safety (ICVES), pp. 174- 179, 16-17 December2014.
- [14] Vong C.M., Wong P.K., Ma Z.Q. and Wong K.I., Application of RFID technology and the maximum spanning tree algorithm for solving vehicle emissions in cities on internet of things. IEEE World Forum on Internet of Things (WF-IoT), pp. 347-352, March 2014.