



International Journal of Innovative Research in Computer and Communication Engineering

(An ISO 3297: 2007 Certified Organization)

Website: www.ijircce.com

Vol. 5, Issue 7, July 2017

Wind Turbine Monitoring and Diagnosis Using CAN

Yogesh Bolegave¹, Prof. M. U. Inamdar²

Department of Electronics and Telecommunication Engineering, CAYMET's Siddhant college of Engineering, Pune, India

ABSTRACT: Electrical energy can be produced using fossil fuels and also by natural resources. The production of electrical energy using fossil fuels is costlier when compared to natural resources. Solar, wind, thermal and tidal energy are most widely used natural resources for the production of electrical energy. Presently wind energy is most widely used natural resources which could reduce the emission of carbon dioxide could reduce the emission of carbon dioxide. A CAN based architecture is designed for the purpose of intensive monitoring and fault diagnosis in wind turbine. It provides a full automation system. CAN (Controller Area Network) Bus is a high speed serial data bus with high transmission rate. CAN Bus interface technique with an integration of electro-mechanical subsystems that embeds network control systems is proposed along with ARM controller to monitor and diagnose the problems in the wind turbine application. CAN BUS will enable the data transmission between two units at the same time without any disturbances. The data transmission time is increased with this CAN protocol. ARM core1 runs with CAN and LPC2148 as wind turbine unit to which sensors are connected and ARM core2 as Fault diagnose and monitoring section. A discussion about weather condition (WC) monitoring and generation voltage (GV) display is also added in this design. Data acquisition node collects the sensor data through CAN protocol. This technique reduces the possibility of fault and increase the monitoring of wind turbine.

KEYWORDS: CAN Bus, Fault Detection, Diagnosis, Wind Turbine, Automation

I. INTRODUCTION

Wind is the movement of air from high pressure area to low pressure area caused by change in temperature within the atmosphere. Wind energy is the most developing renewable energy nowadays. Using such wind energy a turbine is allowed to rotate and electricity is generated. Wind turbine is a rotating mechanical device that converts wind energy in to mechanical energy resulting in the production of electricity. However, Wind turbines are fault prone, that is they are deployed in harsh environment such as desert, plains apart from that they are complex electromechanical system that are located far away from the control center. So the chance of fault occurrence and the side effects will be more, even it leads to power off. It is necessary to develop the remote monitoring and fault diagnosis system to monitor the run time status and the diagnosis of fault to improve the efficiency and the life time service of the wind turbine. Wind turbine monitoring system collects the parameters such as Speed, Temperature, vibration, power, voltage and current. Depending on the collected data from the monitoring system analysis is done and the fault diagnosis system makes the decision of location and the type of fault to be occurs in the wind turbine. CAN bus is one the Field bus control system used in automation, intelligence and networking. CAN protocol have been designed by Robert Bosch in 1986 for automotive applications as a method for enabling robust serial communication. The advantage of using CAN bus in the automation is an added value to the system and increase its reliability. The purpose of using CAN bus is to enable any system to communicate with other system without putting too much load to the main controller. CAN bus is a fast serial bus with the speed of 1 Mbps that is designed to provide an efficient, reliable and economical link between various CAN systems, sensors and actuators. We use CAN to communicate between the Wind turbine and the control center which adopts client/server frame works to implement the monitoring and fault diagnosis system.

Wind turbines are fault prone, being they deployed in harsh environment such as desert, plains etc. Apart from that they are complex electromechanical system that is located far away from the control centre. So, the chance of fault



International Journal of Innovative Research in Computer and Communication Engineering

(An ISO 3297: 2007 Certified Organization)

Website: www.ijircce.com

Vol. 5, Issue 7, July 2017

occurrence and the side effects will be more, even it leads to huge havoc. It is necessary to develop a remote monitoring and fault diagnosis system to monitor the run time status and the diagnosis of fault to improve the efficiency and the life time service of the wind turbine. This wind turbine monitoring system collects the parameters such as Speed, Temperature, vibration, power, voltage and current. Depending on the collected data from the monitoring system analysis is done and the fault diagnosis system makes the decision of fault location and the type of fault to be occurs in the wind turbine.

A CAN BUS is a fast serial bus with the speed of 1Mbps that is designed to provide an efficient, reliable and economical link between various can system interface, sensors and actuators. A CAN BUS Protocol using a CAN Controller (MCP2510) interfaced with a CAN transceiver (MCP2551) is proposed. CAN bus is one the Field bus control system used in automation, intelligence and networking. The fault monitoring unit contains smart electronic components such as Microcontrollers with ADC, Temperature sensors, humidity sensor, vibration sensors, actuators, buzzers, LCD display, GPRS / GSM module. MCP2510 has two mode of operation which is a default mode CAN. CAN transceiver is required to shift the voltage levels of the microcontroller to those appropriate for the CAN bus. The protocol is also widely used today in industrial automation and other areas of networked embedded control, with applications in diverse products such as production machinery, medical equipment, building automation, weaving machines, and wheelchairs. The CAN Bus based system for monitoring and fault diagnosis which will enable any system to communicate with other system without putting too much load to the main controller. The existing fuzzy logic fault diagnosis will to find the exact fault location using Neural Network Classifier and Support Vector Machine (SVM). The main objective of the project is provide full automation system in monitoring as well as facilitating effective diagnose as required automatically in the wind turbine. This will be well advanced, more reliable and faster than the existing fault monitoring by fuzzy logic technology.

II. INTRODUCTION OF CAN BUS

CAN bus is one the Field bus control system used in automation, intelligence and networking. CAN protocol have been designed by Robert Bosch in 1986 for automotive applications as a method for enabling robust serial communication. It defines a standard for efficient and reliable communication between sensor, actuator, controller, and other nodes in real-time applications. CAN is the de facto standard in a large variety of networked embedded control systems. The early CAN development was mainly supported by the vehicle industry: CAN is found in a variety of passenger cars, trucks, boats, spacecraft, and other types of vehicles. The protocol is also widely used today in industrial automation and other areas of networked embedded control, with applications in diverse products such as production machinery, medical equipment, building automation, weaving machines, and wheelchairs.

In the automotive industry, embedded control has grown from stand-alone Systems to highly integrated and networked control systems. By networking electro-mechanical subsystems, it becomes possible to modularize functionalities and hardware, which facilitates reuse and adds capabilities. The advantage of using CAN bus in the automation is an added value to the system and increase its reliability. The purpose of using CAN bus is to enable any system to communicate with other system without putting too much load to the main controller. CAN bus is a fast serial bus with the speed reliable and economical link between various CAN systems, sensors and actuators. We use CAN to communicate between the Wind turbine and the control centre which adopts client/server frameworks to implement the monitoring and fault diagnosis system.

III. FAULT DETECTION IN WIND TURBINE

Fault is defined as the termination of the capability of an object to complete a function. When a failure occurs inside the wind turbine, e.g. high oil temperature in gearbox, the control unit logs the failure directly or registers the consequences of the fault, and responds referring to the type of the malfunction. Sometimes, in order to avoid safety hazards or main system breakdowns, the turbine has to be shut down. Often they are restarted because of wrong failure detection, which could be caused by noise within the system, and therefore these faults are not considered as crucial problems. If the failure is serious, a visual inspection has to be made which can be carried out by the operators or by authorized personnel. Finally whenever a major failure has happened, a report is documented.

International Journal of Innovative Research in Computer and Communication Engineering

(An ISO 3297: 2007 Certified Organization)

Website: www.ijircce.com

Vol. 5, Issue 7, July 2017

Wind turbine rotors are prone to acquire creep and corrosion fatigue, which can be observed as cracks and delimitations in the blades. Moreover, dirt, ice, bird collisions, dampness or manufacturing defects can cause the rotor blades being imbalance and having asymmetric aerodynamic. Gear tooth damages, high speed and low speed shafts faults are the most common failures in wind turbine gearbox. Typically, temperature, speed, humidity, voltage and current measurement is done. Stator, bearing and the rotor inside the generator are subject to failures. Mostly, the faults in generators can be detected by current measurement.

IV. SYSTEM DESIGN

The system consists of microcontroller, CAN controller, and parameters of wind turbine. Microcontroller is the key element in processing module which keeps on monitors the wind turbine parameters. The block diagram of processing module is shown in Fig. 1. CAN controller is used to communicate between the wind turbine and the database. For every particular amount of time, microcontroller preprocesses the sensed data and it will update the parameter values to the central database. RS232 is used for serial communication between the simulink and the CAN Bus.

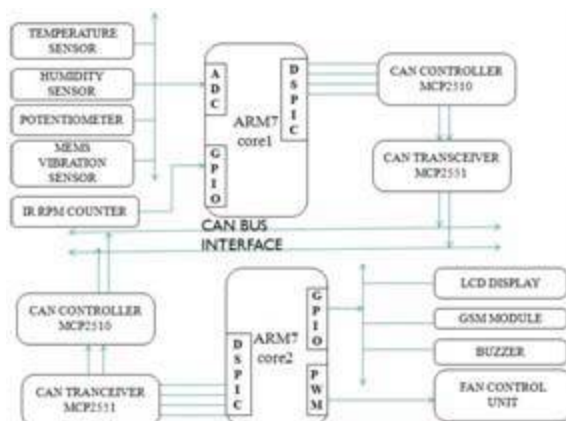

Figure 1: Block diagram of Processing Module

The project deals with the data transmission between two units in the exact time without any disturbance. The data transmission time is increased with the CAN protocol. ARM core1 runs with DSPIC (Digital Signal Peripheral Interface Controller) & CAN (Controller Area Network) and LPC2148 as wind turbine unit to which sensors are connected and ARM core2 runs as monitoring section with multiple alert units. A weather condition (WC) based monitoring of wind blades and generation voltage (GV) display is also added in this design. Data acquisition node collects the sensor data through CAN protocol. Inside the wind turbine, temperature in gearbox or the control unit leads to failure directly or registers the consequences of the fault and referring to the type of the malfunctions. The Humidity Sensor (HMP50) senses the percentage of humidity in the atmosphere that prevents the running of turbine during rainy season or more humid environment by shutting down immediately. This prevents the wind turbine rotors prone to acquire creep and corrosion fatigue, which can be observed as cracks and delaminating in the blades. In the turbine, coolant is used to balance the temperature which level of oil is formulated through an oil indicator sensor. An automatic fire extinguisher system can be annexed along with the temperature sensor (TMP36) that will be set ON during abnormal heat range or during flame catch up. IR RPM counter will rate the speed of the turbine. It is an Infra Red tachometer with emitter diode that is contactless and more accurate. On projection over the turbine, speed can be detected. The Piezo electric transducer is used as vibration sensor that senses the vibrations and aerodynamic imbalance in it. Other factors such as turbine vibration and aerodynamic imbalance also need to be considered.

The entire system is developed as hardware based system using LPC2148 Trainer Kit and its associated devices embedded within it. The coding is formulated in Embedded C which is compiled using a Keil4.0 μ Vision. The simulation is predominately developed in the tool ORCAD design laboratory.

International Journal of Innovative Research in Computer and Communication Engineering

(An ISO 3297: 2007 Certified Organization)

Website: www.ijirce.com

Vol. 5, Issue 7, July 2017

LCD displays the power generated, rated RPM of the turbine, temperature, humidity, oil level measurements exactly. It is possible only through a CAN Bus controller interface. Any occurrence of hazard can be alerted by using buzzers and emergency lights. The fault alerting is additionally gives to the clients/server system through GPRS / through GSM mobile module. Sometimes, in order to avoid hazards or main system breakdowns, the turbine has been shut down. This is done by automatic switching ON/OFF. If the failure is serious, a visual inspection has to be made which can be carried out by the operators or by authorized personnel. Finally, the automation system and accuracy in diagnosis will make the entire system protected from vital damages with least maintenance.

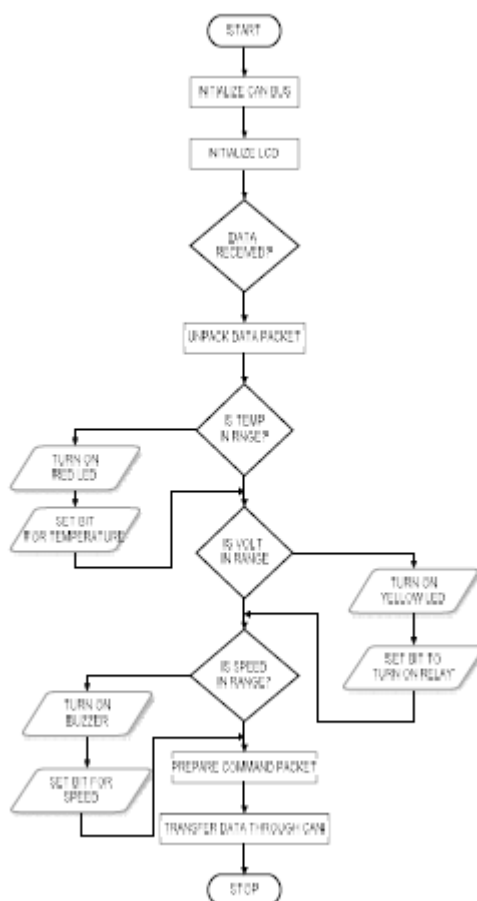

Fig.2 Flow Chart

V. CAN INTERFACE MODULE

CAN interface module is used to communicate the monitored parameters between the wind turbine and the control center. The CAN interface module consists of three components CAN Transceiver (MCP 255 1), CAN Controller (MCP 25 10), DSPIC. The block diagram of CAN interface module is given in the Fig 3. MCP 25 10 has two mode of operation: basic CAN which is a default mode and PeliCAN.

CAN transceiver is required to shift the voltage levels of the microcontroller to those appropriate for the CAN bus. This will help to create the differential signal CAN High and CAN Low which are needed in CAN bus.

This device must be able to withstand voltage tolerance which may be caused by noise pickup. DSPIC which contains the feature of signal processing.

International Journal of Innovative Research in Computer and Communication Engineering

(An ISO 3297: 2007 Certified Organization)

Website: www.ijirce.com

Vol. 5, Issue 7, July 2017

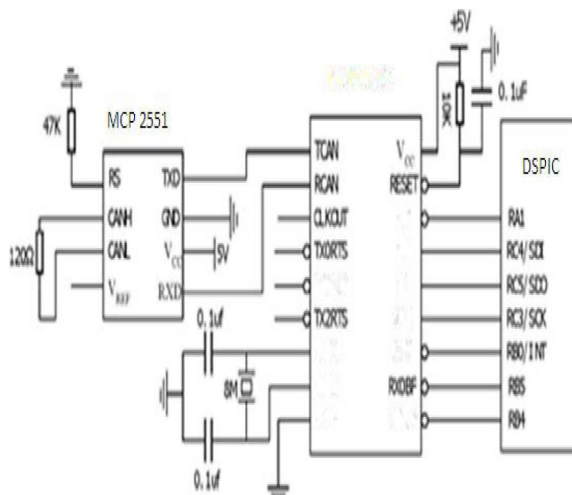

Fig.3 CAN Interface Module

VI. RESULT AND CONCLUSION

The fault identification is done using FUZZY LOGIC and the parameters are measured through the CAN interface module the monitored data is analyzed and send to PC through UART. The location and the type of faults are analyzed before it occurs and are transmitted from wind turbine to the control centre through CAN bus. The effect of harsh condition and the nature of large electromechanical system are the causes of fault to be occurred in the wind turbine. It is very important perform the monitoring and fault diagnosis of wind turbine parameters. The CAN protocol which is used for serial communication which provides high data transmission rate and reliability. Therefore in this paper, the design of a remote monitoring and fault diagnosis system based on CAN. Finally the System performance and the efficiency is effective and reliable.

REFERENCES

- [1] IEEE REFERENCE PAPER 978-1-4673-5301-4/13/\$31.00 ©2013
- [2] Fang Li, Lifang Wang, Chenglin Liao, CAN (Controller Area Network) Bus Communication system Based on Matlab/Simulink. Available:<http://www.ieeexplore.ieee.org>.
- [3] Wang chuhang Network Center of Chanchun Normal University, Remote Monitoring and Diagnosis System for Wind Turbine.
- [4] Abdulwahed A. Salem, Ahmed Abu-Siada, and Syed Islam, (2014), "Condition Monitoring Techniques of the Wind Turbines Gearbox and Rotor", International Journal of Electrical Energy, Vol.2, Iss.1, pp53-56
- [5] Amirat.Y, V. Choqueuse, (2010) "Wind turbines condition monitoring and fault Diagnosis using generator current amplitude Demodulation", IEEE International Energy Conference, Vol.10, Iss.978, pp9380-9387.
- [6] Bouthaina Abichou1, Diana Flórez 2, Moamar Sayed-Mouchaweh1, Houari Toubakh1, Bruno François2, (2014) "Fault Diagnosis Methods for Wind Turbines Health Monitoring: a Review European Conference of The Prognostics And Health Management Society, Vol.4, Iss.6, pp343-349.
- [7] Donatella Zappalá1, Christopher J. Crabtree1, Peter J. Tavner1, Shuangwen Sheng2 (2013) "Side-band algorithm for automatic wind turbine gearbox fault detection and diagnosis", IET Renewable Power Generation, Vol.8, Iss.4, pp380-389.
- [8] Jun Hang, Jianzhong Zhang (2013) "Fault diagnosis of wind turbine based on multi sensors information fusion technology", IET Renewable Power Generation, Vol.8, Iss.3, pp.289-298.