



International Journal of Innovative Research in Computer and Communication Engineering

(An ISO 3297: 2007 Certified Organization)

Website: www.ijirccce.com

Vol. 5, Issue 3, March 2017

An Automatic Electric Wheel Chair for Blind People

Keerthana K¹, Keerthana M¹, Mirunalini S¹, Prabhavathi R¹, M Devaki², Dr. P Kumar²

B.E. Students, Department of ECE, K. S. Rangasamy College of Technology, Tiruchengode, Tamil Nadu, India¹

Department of ECE, K. S. Rangasamy College of Technology, Tiruchengode, Tamil Nadu, India²

ABSTRACT: This is an automatic electric wheel chair mainly to aid visually challenged people for their independent mobility. In this context an intelligent system has been proposed for guiding individuals who are blind and partially sighted. This system is used to enable blind peoples to move with the same ease and confidence as a sighted people. The system is linked with map module with the help of the ARM controller to pin point the location of the blind person and to establish a two way communication path in a wireless fashion. Moreover it provides the direction information as well as information to avoid obstacles by using ultra sonic sensors. The whole system is designed to be small, light with the wheel chair module. This result shows that the person using this system could move independently and safely.

I. INTRODUCTION

In this project ARM7 microcontroller is used to support the entire system. An oscillator is used to generate 40KHZ frequency signal. Then the generated frequency signal is given to ultrasonic transmitter. The ultrasonic transmitter is constructed with two inverted buffer connected in parallel. Depending on the frequency the buffer on and off time is varied. In this 40KHZ ultrasonic wave is generated and transmitted. From this, the microcontroller monitors the distance between the object and the chair and if any obstacles found very near, the alarm makes the sound to indicate the blind people.

In this automatically controlled user just need to say the location from the saved destination. Then the wheel chair will automatically move into the direction of saved destination by using encoder wheels. The proposed Speech Recognition Based Wheelchair Operation allows visually disabled person to control the wheelchair easily without the need to use hands. The movement of the powered wheelchair depends on the motor control and drive system which consists of microcontroller and motor driving. Once the voice recognition system recognizes the voice commands in comparison to the stored memory, the respective coded digital signals would be sent to the microcontroller which then controls the wheelchair accordingly.

International Journal of Innovative Research in Computer and Communication Engineering

(An ISO 3297: 2007 Certified Organization)

Website: www.ijirccce.com

Vol. 5, Issue 3, March 2017

II. BLOCK DIAGRAM

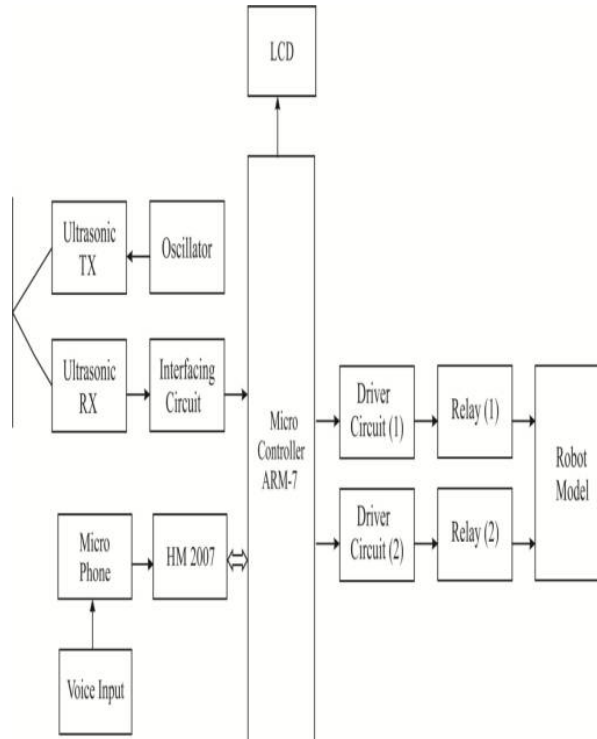

Fig 2.1 Block diagram of a Wheel Chair

A. BLOCK DIAGRAM DESCRIPTION:

A.1 MICRO CONTROLLER ARM-7:

The LPC2141/42/44/46/48 microcontrollers are based on a 16-bit/32-bit ARM7TDMI-SCPU with real-time emulation and embedded trace support, that combine microcontroller with embedded high speed flash memory ranging from 32 kB to 512 kB. A 128-bit wide memory interface and a unique accelerator architecture enable 32-bit code execution at the maximum clock rate. For critical code size applications, the alternative 16-bit Thumb mode reduces code by more than 30% with minimal performance penalty.

Due to their tiny size and low power consumption, LPC2141/42/44/46/48 are ideal for applications where miniaturization is a key requirement, such as access control and point-of-sale. Serial-communications interfaces ranging from a USB 2.0 Full-speed device, multiple UARTs, SPI, SSP to I2C-bus and on-chip SRAM of 8 kB up to 40 kB, make these devices very well suited for communication gateways and protocol converters, soft modems, voice recognition and low end imaging, providing both large buffer size and high processing power.

Various 32-bit timers, single or dual 10-bit ADC(s), 10-bit DAC, PWM channels and 45 fast GPIO lines with up to nine edge or level sensitive external interrupt pins make these microcontrollers suitable for industrial control and medical systems.

International Journal of Innovative Research in Computer and Communication Engineering

(An ISO 3297: 2007 Certified Organization)

Website: www.ijirccce.com

Vol. 5, Issue 3, March 2017

III. VOICE RECOGNITION MODULE

The speech recognition module basically consists of:

3.1 Voice Recognition Chip:

It is the heart of the entire system. HM2007 is a voice recognition chip with on-chip analog front end, voice analysis, recognition process and system control functions. The input voice command is analyzed, processed, recognized and then obtained at one of its output port which is then decoded, amplified and given to motors of robot. This circuit allows the user to choose either the 0.96 second word length (40 word vocabulary) or the 1.92 second word length (20 word vocabulary). For memory the circuit uses an 8K X 8 static RAM. The chip has two operational modes; *manual mode and CPU mode*. The CPU mode is designed to allow the chip to work under a host computer. When the HM2007 recognizes a command it can signal an interrupt to the host CPU and then relay the command code. The HM2007 chip can be cascaded to provide a larger word recognition library. The circuit we are building operates in the *manual mode*. The manual mode allows one to build a standalone speech recognition board that doesn't require a host computer and may be integrated into other devices to utilize speech control. The major components of this design are: a speech recognition chip, memory, keypad, and LED 7-segment display. The chip is designed for speaker dependent (one user) applications, but can be manipulated to perform speaker independent (multiple users) applications. The keypad and LED 7-segment display will be used to program and test the voice recognition circuit. The HM2007 is a single-chip complementary metal-oxide semiconductor (CMOS) voice recognition large-scale integration (LSI) circuit. The chip contains an analog front end voice analysis, recognition, and system control functions. The chip may be used in a stand-alone or connected CPU.

3.2 Microphone:

It takes the analog voice commands and sends it to voice recognition chip (HM 2007) in the form of electrical signal. The human ear has an auditory range from 10 to 15,000 Hz. Sound can be picked up easily using a microphone and amplifier.

3.3 Keypad:

It is used for training/programming the chip. It also allocates definite memory locations to voice commands. The keypad is made up of 12 switches.

3.4 7-segment Display:

It is used to test the voice recognition circuit. The 7 segment display is used as a numerical indicator on many types of test equipment. It is an assembly of light emitting diodes which can be powered individually. They most commonly emit red light. Powering all the segments will display the number 8. Powering a,b,c,d and g will display the number 3. Numbers 0 to 9 can be displayed. The d.p represents a decimal point.

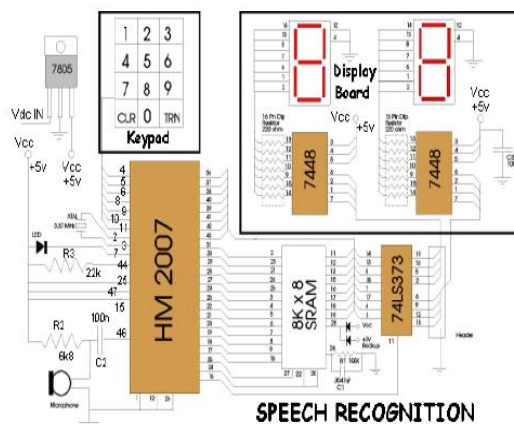

Fig 3.4



International Journal of Innovative Research in Computer and Communication Engineering

(An ISO 3297: 2007 Certified Organization)

Website: www.ijirccce.com

Vol. 5, Issue 3, March 2017

3.5 To Train:

To train the circuit begin it by pressing the word number in which you want to train on the keypad. Use any numbers between 1 and 40. For example press the number "1" to train word number 1. When you press the number(s) on the keypad the red led will turn off. The number is displayed on the digital display. Next press the "#" key for train. When the "#" key is pressed it signals the chip to listen for a training word and the red led turns back on. Now speak the word you want the circuit to recognize into the microphone clearly. The LED should blink off momentarily, this is a signal that the word has been accepted. Continue training new words in the circuit using the procedure outlined above. Press the "2" key then "#" key to train the second word and so on. The circuit will accept up to forty words. You do not have to enter 40 words into memory to use the circuit. If you want you can use as many word spaces as you want.

3.6 Recognition:

The circuit is continually listening. Repeat a trained word into the microphone. The number of the word should be displayed on the digital display. For instance if the word "directory" was trained as word number 25. Saying the word "directory" into the microphone will cause the number 25 to be displayed.

IV. ROBOT ASSEMBLY

L293D is a dual H-Bridge motor driver, so with one IC we can interface two DC motors which can be controlled in both clockwise and counter clockwise direction and if you have motor with fix direction of motion then you can make use of all the four I/Os to connect up to four DC motors. L293D has output current of 600mA and peak output current of 1.2A per channel. Moreover for protection of circuit from back EMF output diodes are included within the IC. The output supply (VCC2) has a wide range from 4.5V to 36V, which has made L293D a best choice for DC motor driver.

As you can see in the circuit, three pins are needed for interfacing a DC motor (A, B, Enable). If you want the o/p to be enabled completely then you can connect Enable to VCC and only 2 pins needed from controller to make the motor work.

A	B	Description
0	0	Motor stops/breaks
0	1	Motor runs anticlockwise
1	0	Motor runs clockwise
1	1	Motor stops/breaks

Fig 4.2:truth table

As per the truth mentioned in the image above its fairly simple to program the microcontroller. It's also clear from the truth table of BJT circuit and L293D the programming will be same for both of them, just keeping in mind the allowed combinations of A and B. We will discuss about programming in C as well as assembly for running motor with the help of a microcontroller.

V. ULTRASONIC SENSOR

The HC-SR04 ultrasonic sensor uses sonar to determine distance to an object like bats or dolphins do. It offers excellent range accuracy and stable readings in an easy-to-use package. Its operation is not affected by sunlight or black

International Journal of Innovative Research in Computer and Communication Engineering

(An ISO 3297: 2007 Certified Organization)

Website: www.ijirccce.com

Vol. 5, Issue 3, March 2017

material like Sharp rangefinders are (although acoustically soft materials like cloth can be difficult to detect). Similar in performance to the SRF005, but with the low-price of a Sharp infra-red sensor. A short ultrasonic pulse is transmitted at the time 0, reflected by an object. The sensor receives this signal and converts it to an electric signal. The next pulse can be transmitted when the echo is faded away. This time period is called cycle period. The recommended cycle period should be no less than 50ms. If a 10 μ s width trigger pulse is sent to the signal pin, the Ultrasonic module will output eight 40kHz ultrasonic signal and detect the echo back. The measured distance is proportional to the echo pulse width and can be calculated by the formula above. If no obstacle is detected, the output pin will give a 38ms high level signal.

VI. RELAY

A relay is an electrically operated switch. Current flowing through the coil of the relay creates a magnetic field which attracts a lever and changes the switch contacts. The coil of a relay passes a relatively large current, typically 30mA for a 12V relay, but it can be as much as 100mA for relays designed to operate from lower voltages. Most ICs (chips) cannot provide this current and a transistor is usually used to amplify the small IC current to the larger value required for the relay coil. The maximum output current for the popular 555 timer IC is 200mA so these devices can supply relay coils directly without amplification.

Relays are usually SPDT or DPDT but they can have many more sets of switch contacts, for example relays with 4 sets of changeover contacts are readily available. Most relays are designed for PCB mounting but you can solder wires directly to the pins providing you take care to avoid melting the plastic case of the relay. The animated picture shows a working relay with its coil and switch contacts. You can see a lever on the left being attracted by magnetism when the coil is switched on. This lever moves the switch contacts. There is one set of contacts (SPDT) in the foreground and another behind them, making the relay DPDT.

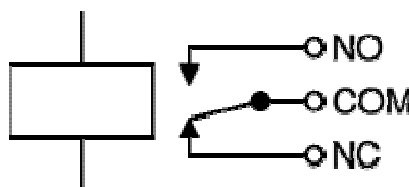

Fig 6.2

The relay's switch connections are usually labelled COM, NC and NO:

- **COM** = Common, always connect to this, it is the moving part of the switch.
- **NC** = Normally Closed, COM is connected to this when the relay coil is **off**.
- **NO** = Normally Open, COM is connected to this when the relay coil is **on**.

VII. MODULE WISE PROJECT SPECIFICATION

7.1 MAX232

1. Low-Voltage, Integrated ESD Applications
2. Operating voltage: +3.0V to +5.5V.
3. Low-Power consumption.
4. Input current is 5 to 40 μ A.

7.2 HM2007

1. 48-pin single chip CMOS voice recognition LSI circuit
2. On-chip analog front end, voice analysis, recognition process and system control
3. Functions.
4. Input current 6 to 15mA.

International Journal of Innovative Research in Computer and Communication Engineering

(An ISO 3297: 2007 Certified Organization)

Website: www.ijirccce.com

Vol. 5, Issue 3, March 2017

7.3 ARM7

As it has following advantages:

1. Inbuilt ADC and Clock is present.
2. Speed is more as compared to other controller or processors.
3. Single operating cycle is required for execution of 1 instruction.
4. RISC architecture is used.

7.4 Ultrasonic sensor: HC-SR04

1. Power Supply: +5V DC
2. Quiescent Current: <2mA
3. Working Current: 15mA
4. Effectual Angle: <15°
5. Ranging Distance: 2cm – 400 cm/1" - 13ft
6. Resolution: 0.3 cm
7. Measuring Angle: 30 degree
8. Trigger Input Pulse width: 10uS
9. Dimension: 45mm x 20mm x 15mm

VIII. SOFTWARE TOOLS

8.1 KEIL C COMPILER:

The new Keil μ Vision4 IDE has been designed to enhance developer's productivity, enabling faster, more efficient program development. μ Vision4 introduces a flexible window management system, enabling you to drag and drop individual windows anywhere on the visual surface including support for Multiple Monitors. The μ Vision IDE from Keil combines project management, make facilities, source code editing, program debugging, and complete simulation in one powerful environment. The μ Vision development platform is easy to use and helping you quickly creates embedded programs that work. The μ Vision editor and debugger are integrated in a single application that provides a seamless embedded project development environment.

The Keil μ Vision Debugger accurately simulates on-chip peripherals (I²C, CAN, UART, SPI, Interrupts, I/O Ports, A/D Converter, D/A Converter, and PWM Modules) of your 8051 device.

IX. RESULT

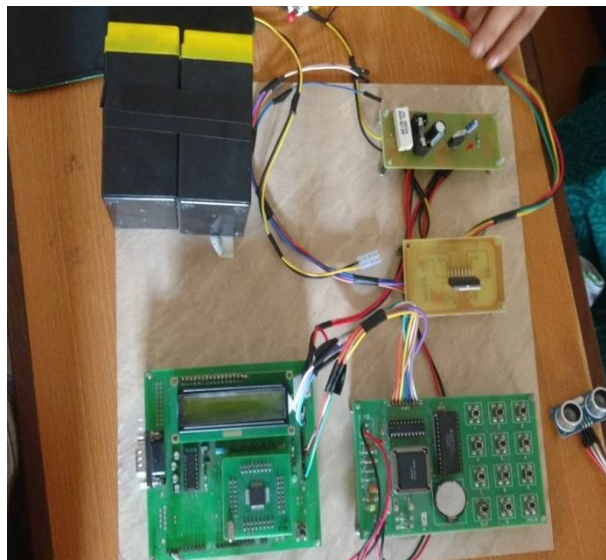



International Journal of Innovative Research in Computer and Communication Engineering

(An ISO 3297: 2007 Certified Organization)

Website: www.ijircce.com

Vol. 5, Issue 3, March 2017

X. CONCLUSION

Thus this Wheel chair can be used like a car which works automatically when GSM interface is added to this device. The proposed system based on ARM microcontroller is found to be more compact, user friendly and less complex, which can readily be used in order to perform several tedious and repetitive tasks. Though it is designed keeping in mind about the need to aid blind people using ARM controller, it can be extended for other purposes such as commercial & research applications. Due to the probability of high technology (ARM microcontroller) used, this "AUTOMATIC WHEEL CHARE FOR BLIND PEOPLE" system is fully software controlled with less hardware circuit. The feature makes this system is the base for future systems. This system can be further developed by involving GSM interface and can be used as like normal vehicle(car) .

REFERENCES

- [1] Zhijun Li, Shuangshuang Lei, Chun-Yi Su, and Guanglin Li, "Hybrid Brain/Muscle-Actuated Control of An Intelligent Wheelchair" Proceeding of the IEEE International Conference on Robotics and Biomimetics (ROBIO) Shenzhen, China, December 2013.
- [2] Chandan Banerjee¹, Harish Gupta¹, Kumar Sushobhan¹ "Low Cost Speech and Vision Based Wheel Chair For Physically Challenged" Vellore Institute of Technology University, Vellore, India 978-1-4244-5586-7/10/\$26.00 C 2010 IEEE.
- [3] S. Manogna¹, Sree Vaishnavi², B.Geethanjali³, "Head Movement Based Assist System For Physically Challenged" Anna University Manuscript on Dec 10, 2009.
- [4] L.Srinivasavaradhan, G.Chandramouli "Automated Vehicles For Physically and Visually Challenged" MEMSTECH'2008, May 21-24, 2008, Polyana, UKRAINE .
- [5] The 33rd Annual conference of the IEEE industrial Electronics society (IECON), 5-8-2007, Taipei, Taiman "Development of Autonomous Robotic wheelchair controller using Embedded system".
- [6] Axel Techmer, " Real-time Motion Analysis for Monitoring the Rear and Lateral Road" 2004 IEEE Intelligent Vehicles Symposium University of Parma, Italy June 14-17, 2004.
- [7] G. Bourhis, O. Horn and A. Pruski "An autonomous vehicle for people with Motor Disabilities", IEEE Robotics & automation magazine Vo1.8, pp. 20-8-2001 .