



International Journal of Innovative Research in Computer and Communication Engineering

(An ISO 3297: 2007 Certified Organization)

Website: www.ijircce.com

Vol. 5, Issue 8, August 2017

STBC-OFDM using Compressive Sensing Theory for Wireless Systems

Srishti Hajare¹, Shashank Mane²

PG Student (Electronics & Communication), Shri Balaji Institute of Technology and Management,
Madhya Pradesh, India

Assistant Professor, Shri Balaji Institute of Technology and Management, Madhya Pradesh, India

ABSTRACT: STBC-OFDM has higher spectral efficiency and faster synchronization than standard cyclic prefix OFDM (CP-OFDM). STBC-OFDM suffers a high difficulty in supporting high modulation schemes such as PSK in low speed vehicular channels. In vehicular channels, mainly considering here low speed, there occurs a difficulty to completely remove the residual interference when the channel delay spread is large. Also there is performance loss over fast time varying vehicular channels. The performance parameters are compared, between STBC-OFDM and CP-OFDM. Also the proposed scheme shows high and better efficient use of compressive sensing (CS) theory to solve these problems. By the use of inter-block-interference (IBI) there is no need of cancellation. Channel estimation in time domain and data detection in frequency domain can be decoupled in the receiver side of STBC-OFDM. The parameterized channel estimation method proposed is based on priori aided compressive sampling matching pursuit (PA-CoSaMP) algorithm. PA-CoSaMP achieves reliable performance over fast vehicular channels. The proposed scheme will be analyzed for efficiency of both systems. STBC-OFDM and CP-OFDM system performance will be simulated and the results will be discussed.

KEYWORDS: STBC-OFDM, CP-OFDM, spectral efficiency, compressive sensing, BER, SNR.

I. INTRODUCTION

The wireless channel is characterized by frequency-selective fading due to the multi-path effect and time-selective fading because of the relative mobility between the transmitter and the receiver. In communication system model, generally it is the case that both frequency-selectivity and time-selectivity are encountered, which means the channel is doubly selective. Due to the robustness to the frequency-selective multipath channel and the low complexity of the frequency domain equalizer, the technology, orthogonal frequency division multiplexing (OFDM) has been widely recognized as one of the key techniques for the next generation broadband wireless communication (BWC) systems. A modulation or transmission scheme, the cyclic prefix orthogonal frequency division multiplexing (CP-OFDM) is widely used to deal with problem of inter-symbol interference (ISI) in wireless communications. Many broadcasting systems use CP-OFDM as their modulation scheme. The broadly used technique, CP-OFDM scheme utilizes the CP to eliminate the inter-block interference (IBI) as well as the inter-carrier-interference (ICI). The role of the cyclic prefix is to turn the linear convolution into a set of parallel attenuations in the discrete frequency domain. In particular, cyclic prefixes which are longer than channel duration should be added as guard intervals between consecutive OFDM data blocks which are inverse discrete Fourier transformed (IDFT) [1][2][3].

Recently, a new modulation scheme has been proposed for broadcasting in terrestrial environments. The processing at the transmitter end of STBC-OFDM is same as that of CP-OFDM. However, I place of inserting cyclic prefix, training symbols are used and inserted as guard intervals. The training sequence could be any known pseudo-random sequence [4]. This paper gives performance comparison on CP-OFDM and STBC-OFDM by comparing the parameters; also it compares spectral efficiency between the two.

International Journal of Innovative Research in Computer and Communication Engineering

(An ISO 3297: 2007 Certified Organization)

Website: www.ijirccce.com

Vol. 5, Issue 8, August 2017

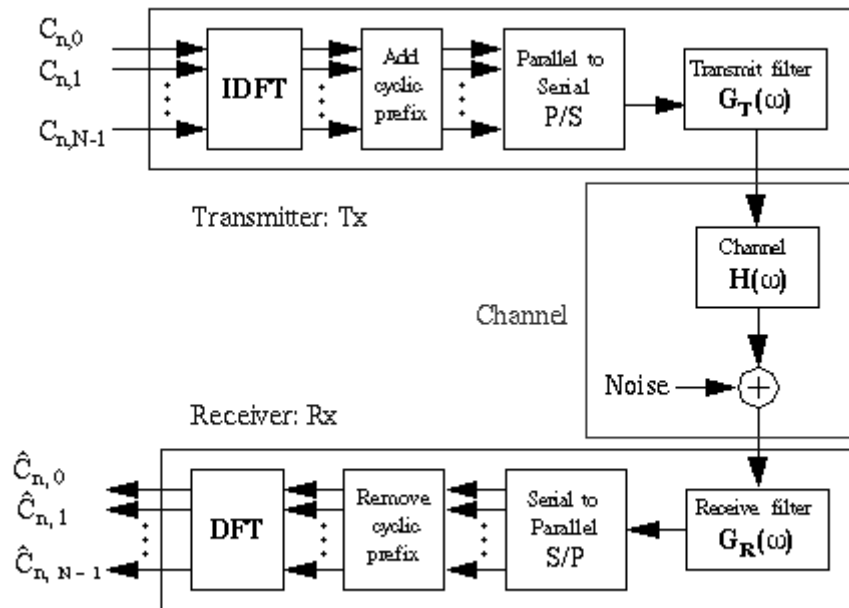

Figure 1 Block Diagram of CP-OFDM.

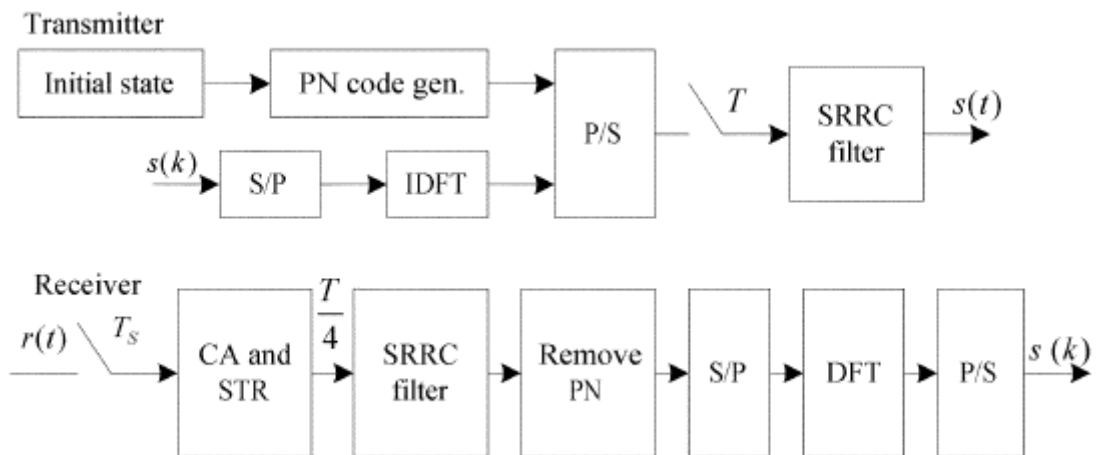

Figure 2 Block Diagram of STBC-OFDM.

The discussion is organized as follows. Next section describes the system model for both CP-OFDM and STBC-OFDM. Section III discusses analytical and simulation results. Section IV offers some conclusions. This paper gives the performance comparison between CP-OFDM and STBC-OFDM. Both systems are compared based on performance parameters bit error rate (BER), signal to noise ratio (SNR). The outline of the paper is as follows.

II. SYSTEM DESCRIPTION

A) CP-OFDM

Considering standard CP-OFDM, where the i th $M \times 1$ information block is precoded by IFFT matrix $F = F_M^{-1} = F_M^H$ with (m, k) th entry to yield time domain block vector. Further CP of length D is inserted between each block vector. The entries of the resulting redundant block are sent finally through the channel. Here we consider both AWGN and Rayleigh channel. The total number of time-domain samples transmitted per block is, $P = M + D$. Consider the

International Journal of Innovative Research in Computer and Communication Engineering

(An ISO 3297: 2007 Certified Organization)

Website: www.ijirce.com

Vol. 5, Issue 8, August 2017

$M \times D$ matrix \bar{F}_{cp} formed by the last D columns of F_M . $P \times M$ matrix corresponding to the combined multicarrier modulation and CP insertion, the block symbols to be transmitted can be simply expressed as $\tilde{s}_{cp}(i) = F_{cp} s_M(i)$. Each block is then serialized to obtain time domain samples $\tilde{s}_n(i)$ and reduce the non-linear distortions which are induced after passing through channel. With $(\cdot)^T$ denoting the transpose the frequency-selective propagation will be modeled as a FIR filter with channel impulse response (CIR) column vector $\mathbf{n} := [n_0, \dots, n_{M-1}]^T$ and additive white Gaussian noise $\tilde{n}_n(i)$ of variance σ_n^2 . The expression of the received symbol block is given as,

$$\tilde{x}_{cp}(i) = H F_{cp} s_M(i) + H_{IBI} F_{cp} s_M(i-1) + \tilde{n}_p(i) \quad (1)$$

Where H is $P \times P$ lower triangular toeplitz filtering matrix and H_{IBI} is $P \times P$ upper triangular matrix that captures IBI.

Equalization of CP-OFDM transmissions relies on the well known property that every circulates matrix can be diagonalized by post- multiplication by IFFT matrices. This CP-OFDM property derives from the fast convolution algorithm based on the overlap-save (OLS) algorithm for block convolution [10]. It also enables one to deal easily with ISI channels by simply taking into account the scalar channel attenuations, e.g., when computing the metrics for the Viterbi decoder. However, it has the obvious drawback that the symbol transmitted on the n th subcarrier cannot be recovered when it is hit by a channel zero ($H_k = 0$). This limitation leads to a loss in frequency (or multipath) diversity.

B) STBC-OFDM

Unlike in CP-OFDM where CP and frequency domain pilots are used, STBC-OFDM symbol includes $s = [c^T \ x^T]$ known time domain pseudo-random sequence $c = [c_0, c_1, \dots, c_{M-1}]^T$ of length M and OFDM data block $x = [x_0, x_1, \dots, x_{N-1}]^T$ of length N . Channel impulse response (CIR) $\mathbf{n} = [n_0, n_1, \dots, n_{L-1}]^T$ which comprises of S resolvable paths can be modeled as [5]

$$n = \sum_{l=0}^{s-1} \alpha_l \delta[n - \tau_l], 0 \leq n \leq L - 1 \quad (2)$$

Where α_l is the gain and τ_l denotes the delay of the l th path normalized to the sampling period at the receiver end, and \mathbf{n} is the CIR vector with the n th entry.

$$n = \begin{cases} \alpha_l, & n = \tau_l, \\ 0, & \text{otherwise,} \end{cases} \quad (3)$$

When passed through the multipath channel, training sequence $d = [d_0, d_1, \dots, d_{M-1}]^T$ which is obtained is given as

$$d = \Psi h + n, \quad (4)$$

Where n is additive White Gaussian Noise (AWGN) and Ψ is vector consisting of every element with mean zero and variance σ^2 . Samples of preceding data block cause inter-block-interference (IBI) to the training sequence of the present OFDM symbol. Similarly, it may happen that the present OFDM data block /symbols will cause interference to the following.

It correctly states the occurrence of interferences which are mutual in condition. This mutual interference between the TS and OFDM block leads to mutual relationship of data detection and channel estimation. Channel estimation is time domain and data detection is frequency domain in STBC-OFDM systems. To solve problem of interference, iterative interference cancellation should be applied for properly estimating channel and accurate data detection.

To address the issue STBC-OFDM is provided with a new perspective. Guard interval length in CP-OFDM and STBC-OFDM is designed to be longer than channel length. In practical environments, channel length is much smaller than guard interval length [6], $L < M$. Even though training sequence received at receiver end may contain some interferences from preceding data block, there always exists a small IBI-free region $y = [d_{L-1}, d_L, \dots, d_{M-1}]^T$ of small length $G = M - L + 1$ which is immune from inter-block-interferences:

$$y = \Phi h + n' \quad (5)$$

International Journal of Innovative Research in Computer and Communication Engineering

(An ISO 3297: 2007 Certified Organization)

Website: www.ijircce.com

Vol. 5, Issue 8, August 2017

'n' is additive white Gaussian noise subjected to the distribution of $CN(0, \sigma^2 I_G)$ and ϕ is toeplitz matrix. Consideration of channel length and system design incite to use IBI-free region of small size to recover channel impulse response with no interference cancellation required.

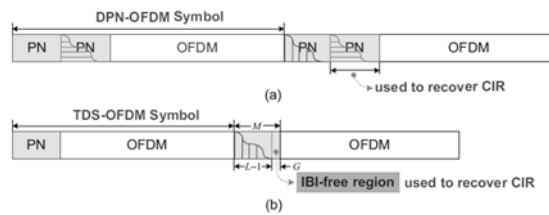

Figure 3 Signal structure comparison: (a) STBC-OFDM with dual PN padding (DPN-OFDM), where the second PN sequence is used for CIR recovery; (b) Compressive sensing based STBC-OFDM, where the IBI-free region of small size is used to reconstruct the high-dimensional CIR using the CS theory.

As given in Fig. 3, the size of the IBI-free region is very small which makes impossible to find unique solution to (5). An extra TS is inserted in DPN-OFDM so that the second TS which is pure can be used to estimate CIR. However, the CS theory proves that the targeted signal can be accurately reconstructed if problem in (4) is considered. Here the condition taken is that the channel is sparse, i.e. dimension of CIR is greater than total number of non-zero entries. Fortunately, numerous experiments have verified and concluded about wireless channel being sparse [7]. Word 'sparse' explains, in wireless communications, the dimension of CIR model than active paths. Hence, considering Fig. 3(b), under compressive sensing theory [9], the sparse CIR can be accurately calculated from IBI-free region of received TS.

III. PERFORMANCE ANALYSIS

This section gives the simulation result of CP-OFDM in context with the compressive sensing theory. The channel used for transmission is Rayleigh channel. This comparison is done in order to show how efficient is STBC-OFDM from CP-OFDM. The Subcarrier modulation constellations which included are QPSK (quadrature phase shift keying), PSK modulation. Assumption is made that each path in the transmission scheme is subjected to independent Rayleigh fading, and the average path gains are normalized so that the signal power remains after passing through the channel which is multipath.

TABLE I System Parameters

Number of subcarrier channel	4
Block size	16
CP length	1.6
Subcarrier spacing	2kHz
Modulation schemes	16PSK/QPSK

International Journal of Innovative Research in Computer and Communication Engineering

(An ISO 3297: 2007 Certified Organization)

Website: www.ijircce.com

Vol. 5, Issue 8, August 2017

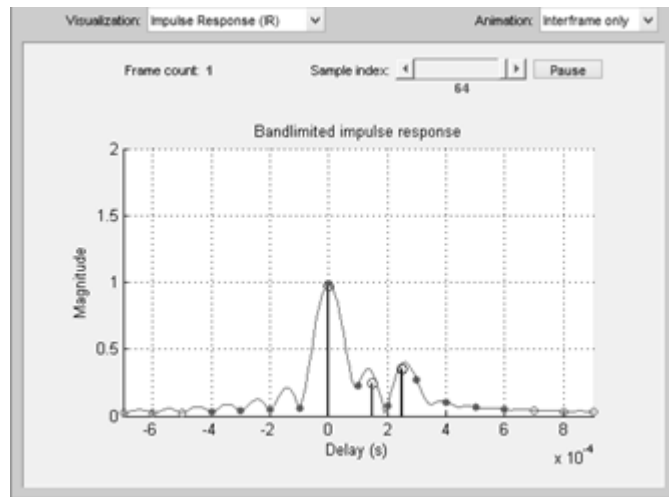

Figure 4 Multipath Channel

Figure 4 gives the diagrammatic form of the signal in multipath channel. The differences between two sub-carriers or the length of the guard interval between two sub-carriers is given. The delay as mentioned is 1.6. it can be said that the length of cyclic prefix is 1.6

Figure 5 gives the performance of CP-OFDM in wireless communication. Under compressive sensing the system is evaluated. Information is transmitted through Rayleigh Channel. The BER v/s SNR of CP-OFDM is given.

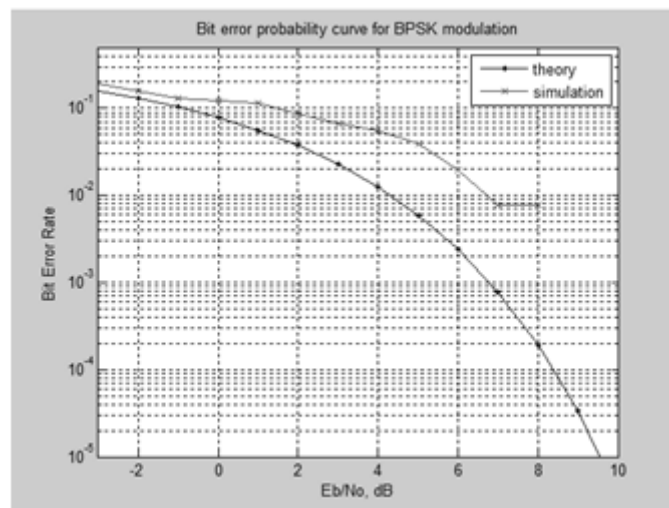

Figure 5 Performance of CP-OFDM

International Journal of Innovative Research in Computer and Communication Engineering

(An ISO 3297: 2007 Certified Organization)

Website: www.ijirccce.com

Vol. 5, Issue 8, August 2017

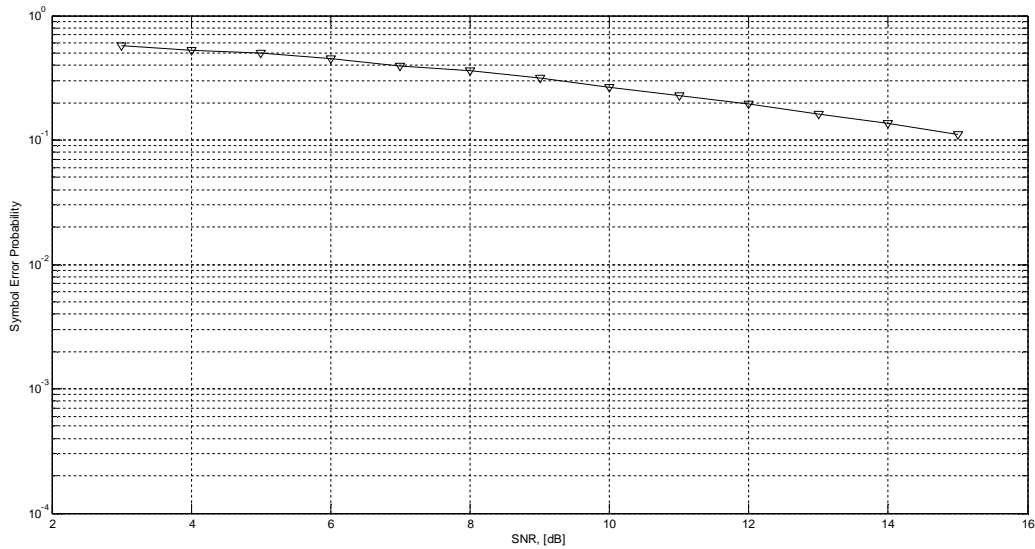

Figure6: Spectral Error Probability

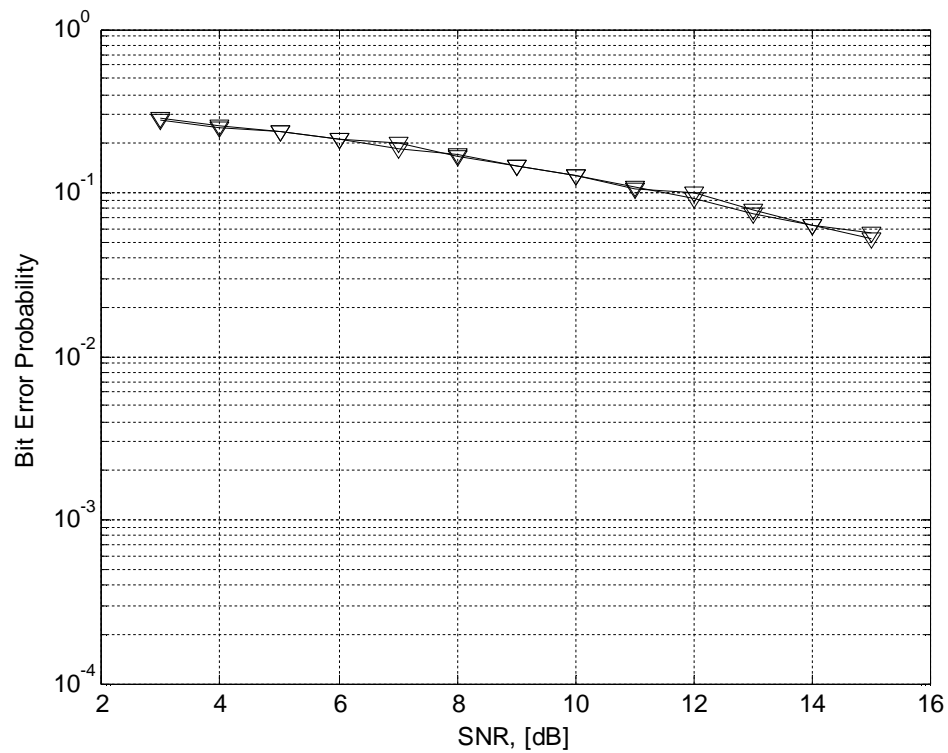

Figure 7 : Bit Error Probability

International Journal of Innovative Research in Computer and Communication Engineering

(An ISO 3297: 2007 Certified Organization)

Website: www.ijirccce.com

Vol. 5, Issue 8, August 2017

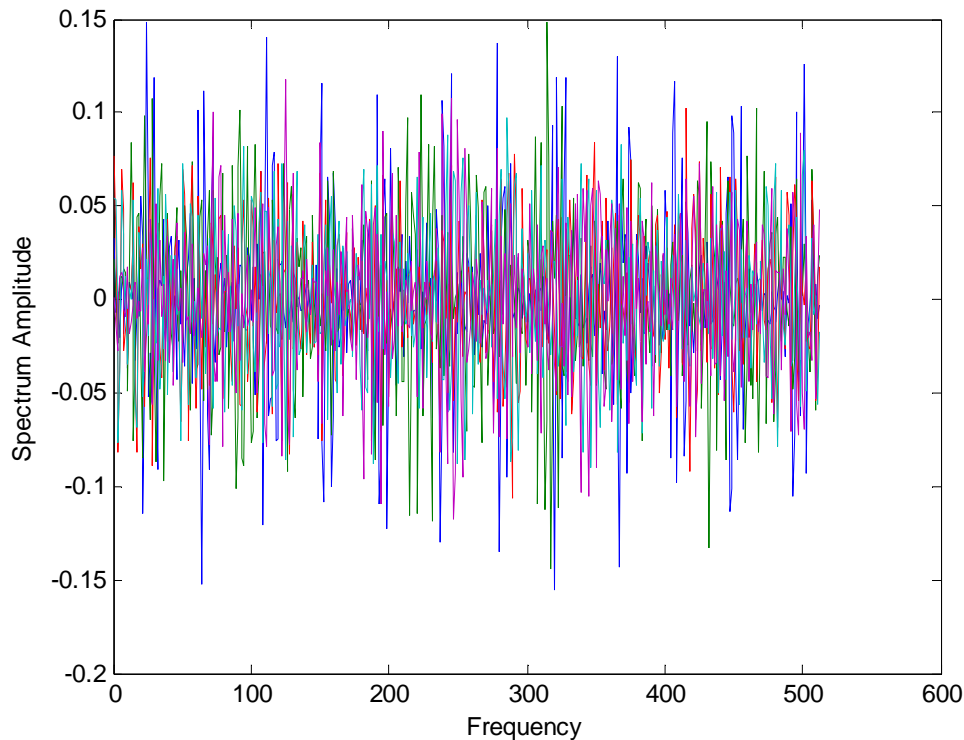

Figure8: Spectral Amplitude Vs Frequency

In STBC-OFDM, as pilots are not used with OFDM data block, hence spectral efficiency is improved in STBC-OFDM. There occurs a problem in STBC-OFDM due to inter-block-interferences, which till now are now removed. Therefore, it can be kept as future scope, where first the IBI is removed and later estimated.

IV. CONCLUSION

Time Domain Synchronous OFDM (STBC-OFDM) has higher spectral efficiency and faster synchronization than standard cyclic prefix OFDM (CP-OFDM). The performance parameters is given of CP-OFDM. Compressive sensing theory can be used efficiently to solve problem in STBC-OFDM interference cancellation is avoided using IBI-free region

REFERENCES

- [1] Z. Yang, L. Dai, J. Wang, J. Wang, and Z. Wang, "Transmit diversity for STBC-OFDM broadcasting system over doubly selective fading channels," *IEEE Trans. Broadcast.*, vol. 57, no. 1, pp. 135–142, Mar. 2011.
- [2] L. Dai, Z. Wang, and Z. Yang, "Time-frequency training OFDM with high spectral efficiency and reliable performance in high speed environments," *IEEE J. Sel. Areas Commun.*, vol. 30, no. 4, pp. 695–707, May 2012.
- [3] M. Muck, M. De Courville, and P. Duhamel, "A pseudorandom postfix OFDM modulator-semi-blind channel estimation and equalization," *IEEE Trans. Signal Process.*, vol. 54, no. 3, pp. 1005–1017, Mar. 2006.
- [4] Zhiyu Yang; Lang Tong; Lin Yang, "Outage probability comparison of CP-OFDM and STBC-OFDM for broadcast channels," *Global Telecommunications Conference, 2002. GLOBECOM '02. IEEE*, vol.1, no., pp.594,598 vol.1, 17-21 Nov. 2002.
- [5] Changyong Pan; Linglong Dai, "Time domain synchronous OFDM based on compressive sensing: A new perspective," *Global Communications Conference (GLOBECOM), 2012 IEEE*, vol., no., pp.4880,4885, 3-7 Dec. 2012.
- [6] B. Su and P. P. Vaidyanathan, "Subspace-based blind channel identification for cyclic prefix systems using few received blocks," *IEEE Trans. Signal Process.*, vol. 55, no. 10, pp. 4979–4993, Oct. 2007.



ISSN(Online): 2320-9801
ISSN (Print): 2320-9798

International Journal of Innovative Research in Computer and Communication Engineering

(An ISO 3297: 2007 Certified Organization)

Website: www.ijircce.com

Vol. 5, Issue 8, August 2017

- [7] M. Duarte and Y. Eldar, "Structured compressed sensing: from theory to applications," IEEE Trans. Signal Process., vol. 59, no. 9, pp. 4053–4085, Sep. 2011.
- [8] B. Muquet, Z. Wang, G. Giannakis, M. De Courville, and P. Duhamel, "Cyclic prefixing or zero padding for wireless multicarrier transmissions?" IEEE Trans. Commun., vol. 50, no. 12, pp. 2136–2148, Dec. 2002.
- [9] E. Candès and M. Wakin, "An introduction to compressive sampling,"
- [10] IEEE Signal Process. Mag., vol. 25, no. 2, pp. 21–30, Feb. 2008. R. Crochiere and L. Rabine, Multirate Digital Signal Processing. Englewood Cliffs, NJ: Prentice-Hall, 1983