



ISSN(Online): 2320-9801  
ISSN (Print) : 2320-9798

# International Journal of Innovative Research in Computer and Communication Engineering

(A High Impact Factor, Monthly, Peer Reviewed Journal)

Website: [www.ijircce.com](http://www.ijircce.com)

Vol. 6, Issue 5, May 2018

## Single Phase Grid-Connected Inverter for PV System with MPPT

Nikhita Kadam<sup>1</sup>, Prof. A. P. Kinge<sup>2</sup>

PG Student [Power System], Dept. of Electrical Engineering, Tssm's Bhivarabai Sawant College of Engineering & Research Narhe, Pune, India

Professor, Dept. of Electrical Engineering, Tssm's Bhivarabai Sawant College of Engineering & Research Narhe, Pune, India

**ABSTRACT:** Solar energy is a very large, inexhaustible source of energy. The Renewable Energy as a source is focused to bring the awareness towards the Green Energy System which provides the pollution free environment. Also it has no heavy mechanical section and is free from noise. The power from the sun intercepted by the earth is approximately  $1.8 \times 10^{11}$  MW, which is many thousands of times larger than the present consumption rate on the earth of all commercial energy sources. Solar tracking system which can be used as a power generating method from sunlight. This method of power generation is simple and is taken from natural resource. This needs only maximum sunlight to generate power. This project presents for power generation and MPPT solar charging system to utilize the maximum solar energy through solar panel by setting the equipment to get maximum sunlight automatically.. The proposed method is to design an electronic circuit to sense the intensity of light and construct a Buck-Boost converter for to step-up and step-down the voltage, and store the maximum utilized output voltage in Lead-Acid Battery.

### I. INTRODUCTION

A solar panel will generate different voltages depending on the different parameters like:

1. The amount of sun light
2. The connected load
3. The temperature of the solar panel.

Throughout the day, as the weather changes, the voltage produced by the solar panel will be constantly varying. Now, for any given voltage, the solar panel will also produce a current (Amps). The amount of Amps that are produced for any given voltage is terminated by a graph called an IV curve, which can be found on any solar panel's specification sheet and typically looks like the figure 1.2 shown below.

# International Journal of Innovative Research in Computer and Communication Engineering

(A High Impact Factor, Monthly, Peer Reviewed Journal)

Website: [www.ijircce.com](http://www.ijircce.com)

Vol. 6, Issue 5, May 2018

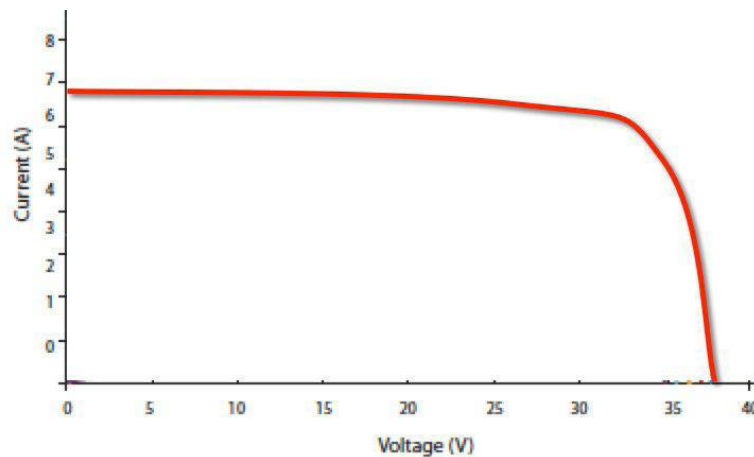

Figure 1: Standard PV I-V Curve

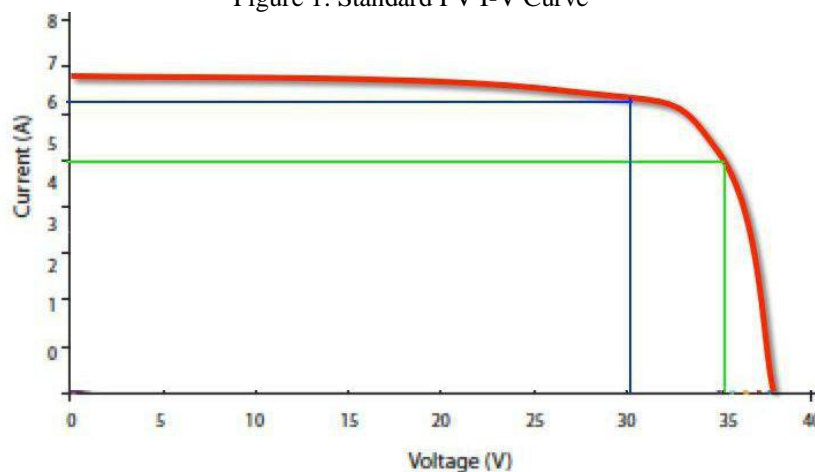

Figure 2: PV I-V Curve for Different Voltages

In Figure 1.2, the blue line shows a solar panel voltage of 30V corresponding to a Current of about 6.2A. The green line shows a Voltage of 35V corresponds to a current of 5A. We know that  $Power = V \times I$  In the picture shown above as you move along the red curve above you will find one point where the Voltage multiplied by its Corresponding Current is higher than anywhere else on the curve. This is called the solar panel's Maximum Power Point (MPP).

## II. LITERATURE SURVEY

Solar panels may make power at very high voltage and current. If all that is fed directly to the battery then it may get overcharged or blast (in extreme cases). A solar charge controller prevents this from happening. It is placed between the solar panels and the battery bank to regulate the charging (current and voltage) of the batteries through solar. For example if your solar panels is making 20V and the battery is of 12V then it will make sure that only 12V reaches the battery. It also prevents the reverse flow of current from batteries to the solar panels during night-time. Basically, without a charge controller it is not possible to safely use solar energy for charging batteries. There are two types of solar charge controllers available in the market PWM (Pulse Width duration) and MPPT (Maximum Power Point Tracking).

MPPT vs PWM Solar Controllers:

A solar charge controller is needed in virtually all solar power systems that utilize batteries. The job of the solar charge controller is to regulate the power going from the solar panels to the batteries. Overcharging batteries will at the least

# International Journal of Innovative Research in Computer and Communication Engineering

(A High Impact Factor, Monthly, Peer Reviewed Journal)

Website: [www.ijircce.com](http://www.ijircce.com)

Vol. 6, Issue 5, May 2018

significantly reduce battery life and at worst damage the batteries to the point that they are unusable. The most basic charge controller simply monitors the battery voltage and opens the circuit, stopping the charging, when the battery voltage rises to a certain level. Older charge controllers used a mechanical relay to open or close the circuit, stop-ping or starting power going to the batteries. More modern charge controllers use Pulse Width Modulation (PWM) to slowly lower the amount of power applied to the batteries as the batteries get closer and closer to fully charged. This type of controller allows the batteries to be more fully charged with less stress on the battery, extending battery life. It can also keep batteries in a fully charged state (called oat) indefinitely. PWM is more complex, but does not have any mechanical connections to break. Example: If you are using a 12V, 100W solar panel with battery of 12V then that panel may make 18V during the time of peak sunshine. However PWM will only give 12V and 5.56 current to the battery. You will get only 66W(125.56) from your 100W panel and the extra 6 Volts will be wasted. The most recent and best type of solar charge controller is called Maximum Power Point Tracking or MPPT. MPPT controllers are basically able to convert excess voltage into amperage. This has advantages in a couple of diferent areas. Most solar power systems use 12 volt batteries, like you \_nd in cars. (Some use other voltages and the same advantages apply to these systems as well.) Solar panels can deliver far more voltage than is required to charge the batteries. By, in essence, converting the excess voltage into amps, the charge voltage can be kept at an optimal level while the time required to fully charge the batteries is reduced. This allows the solar power system to operate optimally at all times. Another area that is enhanced by an MPPT charge controller is power loss. Lower voltage in the wires running from the solar panels to the charge controller results in higher energy loss in the wires than higher voltage. With a PWM charge controller used with 12v batteries, the voltage from the solar panel to the charge controller typically has to be 18v. Using an MPPT controller allows much higher voltages in the cables from the panels to the solar charge controller. The MPPT controller then converts the excess voltage into additional amps. By running higher voltage in the cables from the solar panels to the charge controller, power loss in the cable is reduced significantly.

The final function of modern solar charge controllers is preventing reverse-current flow. At night, when solar panels are not generating electricity, electricity can actually ow backwards from the batteries through the solar panels, draining the batteries. You've worked hard all day using solar power to charge the batteries; you don't want to waste all that power! The charge controller can detect when no energy is coming from the solar panels and open the circuit, disconnecting the solar panels from the batteries and stopping reverse current ow. Example: When 12V, 100W solar panel makes 18V then it will give 12V to the battery but will also increase the current to 8.34 so that you can get full 100W (128.34) from the panel.

### III. PROPOSED SYSTEM

#### PV based Grid control using MPPT

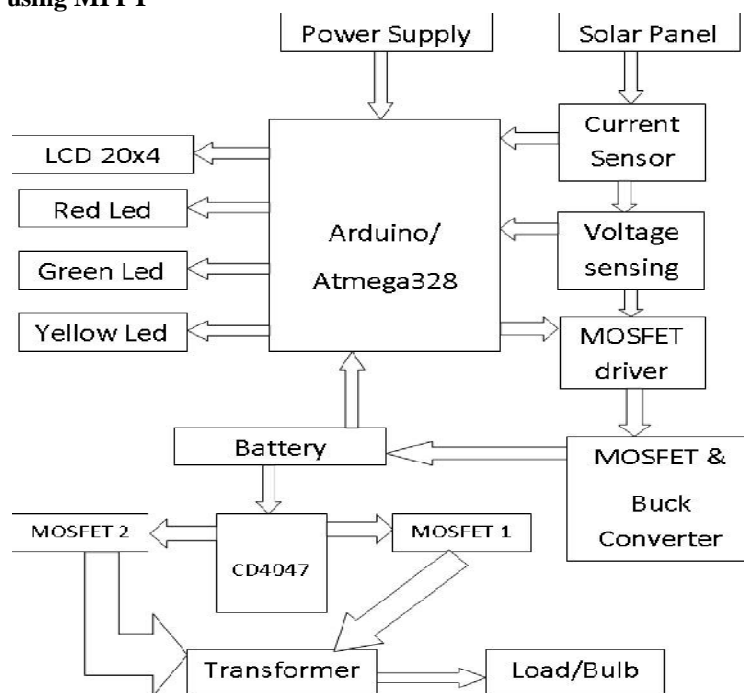

Figure 3. Proposed System

# International Journal of Innovative Research in Computer and Communication Engineering

(A High Impact Factor, Monthly, Peer Reviewed Journal)

Website: [www.ijircce.com](http://www.ijircce.com)

Vol. 6, Issue 5, May 2018

Basic block diagram of PV based Grid control using MPPT, Firstly the sun energy is collected by solar panel and solar panel converts the sun energy into electrical energy i.e. into DC. Then this DC supply is fed to current sensor and voltage sensor to sense the voltage and current. The sensed power will be passed to the microcontroller and buck converter. The buck converter will reduce the excess voltage and then the power will be stored in battery. This can be possible by MPPT controller which will convert excess voltage into amperage. so the maximum power will be maintained because power is product of V I. Then the battery supply will be provided to Arduino and Arduino will supply to LCD for display and to indicators. Also this DC supply can be used directly for DC application. and if AC is required then with the help of inverter we can convert it into AC and use for AC load like fan, bulb, AC motor etc

## IV. METHODOLOGY

The input power connector to the solar panels is the screw terminal JP1 and JP2 is the output screw terminal connector to the battery. The third connector JP3 is connection for the load. F1 and F2 are the 5A safety fuses.

The buck converter is made up of the synchronous MOSFET switches Q2 and Q3 and the energy storage devices inductor L1 and capacitors C1 and C2. The inductor smooths the switching current and along with C2 it smooths the output voltage. Capacitor C8 and R6 are a snubber network, used to cut down on the ringing of the inductor voltage generated by the switching current in the inductor. The third MOSFET Q1 is added to allow the system to block the battery power from owing back into the solar panels at night. In my earlier charge controller, this is done by a diode in the power path. As all diodes have a voltage drop a MOSFET is much more efficient. Q1 turns on when Q2 is on from voltage through D1. R1 drains the voltage on the gate of Q1 so it turns off when Q2 turns off. The diode D3 (UF4007) is an ultra fast diode that will start conducting current before Q3 turns on. It is supposed to make the converter more efficient. The IC IR2104 is a half bridge MOSFET gate driver. It drives the high and the

low side MOSFETs using the PWM signal from the Arduino (Pin -D9). The IR2104 can also be shut down with the control signal (low on pin -D8) from the Arduino.

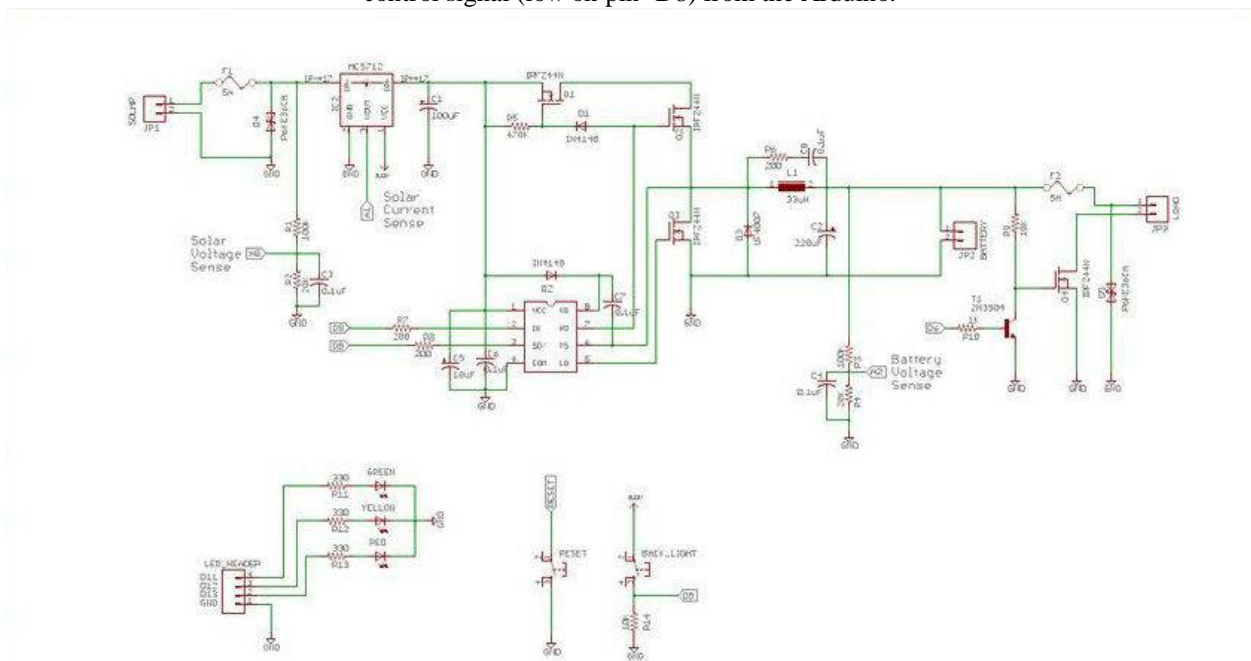

Figure 4. Schematic diagram of project

# International Journal of Innovative Research in Computer and Communication Engineering

(A High Impact Factor, Monthly, Peer Reviewed Journal)

Website: [www.ijircce.com](http://www.ijircce.com)

Vol. 6, Issue 5, May 2018

on pin 3. D2 and C7 are part of the bootstrap circuit that generates the high side gate drive voltage for Q1 and Q2. The software keeps track of the PWM duty cycle and never allows 100%. There are two voltage divider circuits (R1,R2 and R3,R4) to measure the solar panel and battery voltages. The output from the dividers are fed to the voltage signal to Analog pin-0 and Analog pin-2. The ceramic capacitors C3 and C4 are used to remove high frequency spikes. The mosfet Q4 is used to control the load. The driver for this mosfet consists of a transistor and resistors R9, R10. The diode D4 and D5 are TVS diodes used for over voltage protection from solar panel and load side. The current sensor ACS712 senses the current from the solar panel and feeds to the Arduino analog pin-1. The 3 LEDs are connected to the digital pins of the microcontroller and serve as an output interface to display the charging state. Reset switch is helpful if the code gets stuck. The back light switch is to control the back light of LCD display.

## V. SOFTWARE AND ALGORITHM

The Maximum Power Tracker uses an iterative approach to finding this constantly changing MPP. This iterative method is called Perturb and Observe or hill climbing algorithm. To achieve MPPT, the controller adjusts the voltage by a small amount from the solar panel and measures power, if the power increases, further adjustments in the direction are tried until power no longer increases. The voltage to the solar panel is increased initially, if the output power increases, the voltage is continually increased until the output power starts decreasing. Once the output power starts decreasing, the voltage to the solar panel is decreased until maximum power is reached. This process is continued until the MPPT is attained. This result is an oscillation of the output power around the MPP.

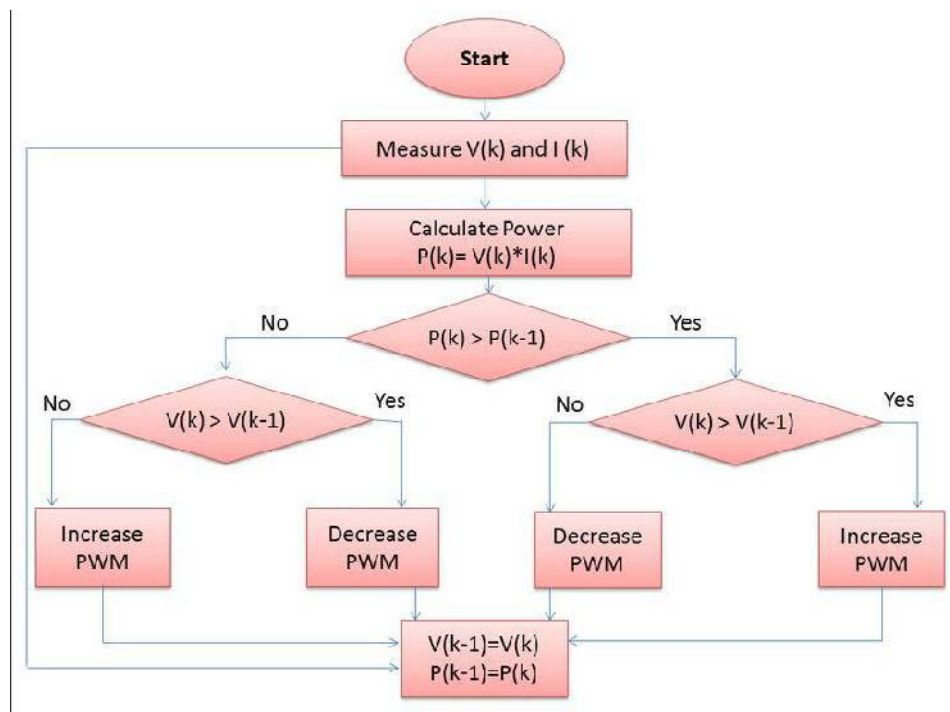

Figure 5. Algorithm

# International Journal of Innovative Research in Computer and Communication Engineering

(A High Impact Factor, Monthly, Peer Reviewed Journal)

Website: [www.ijircce.com](http://www.ijircce.com)

Vol. 6, Issue 5, May 2018

## VI. SIMULATION AND ITS RESULTS

1 Simulation of single phase grid connected in-verter using MPPT2 Results of simulation of single phase grid connected inverter using MPPT

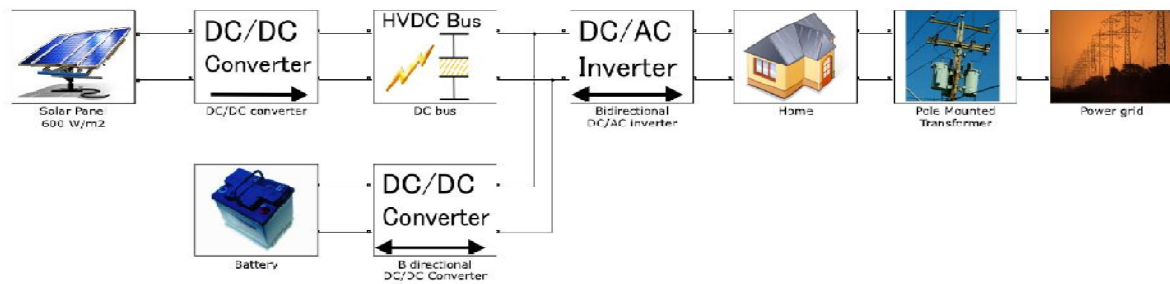

Figure 6. Simulation of single phase grid connected inverter using MPPT

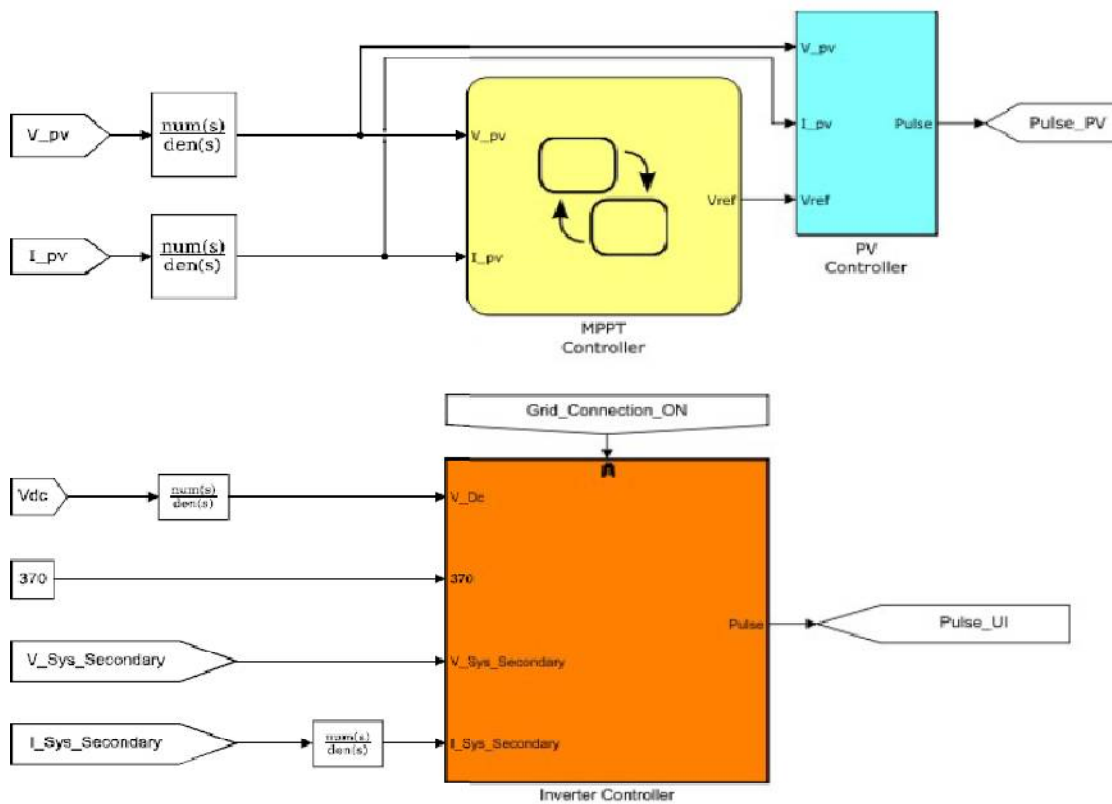

Figure.7. Simulation block of MPPT

# International Journal of Innovative Research in Computer and Communication Engineering

(A High Impact Factor, Monthly, Peer Reviewed Journal)

Website: [www.ijircce.com](http://www.ijircce.com)

Vol. 6, Issue 5, May 2018

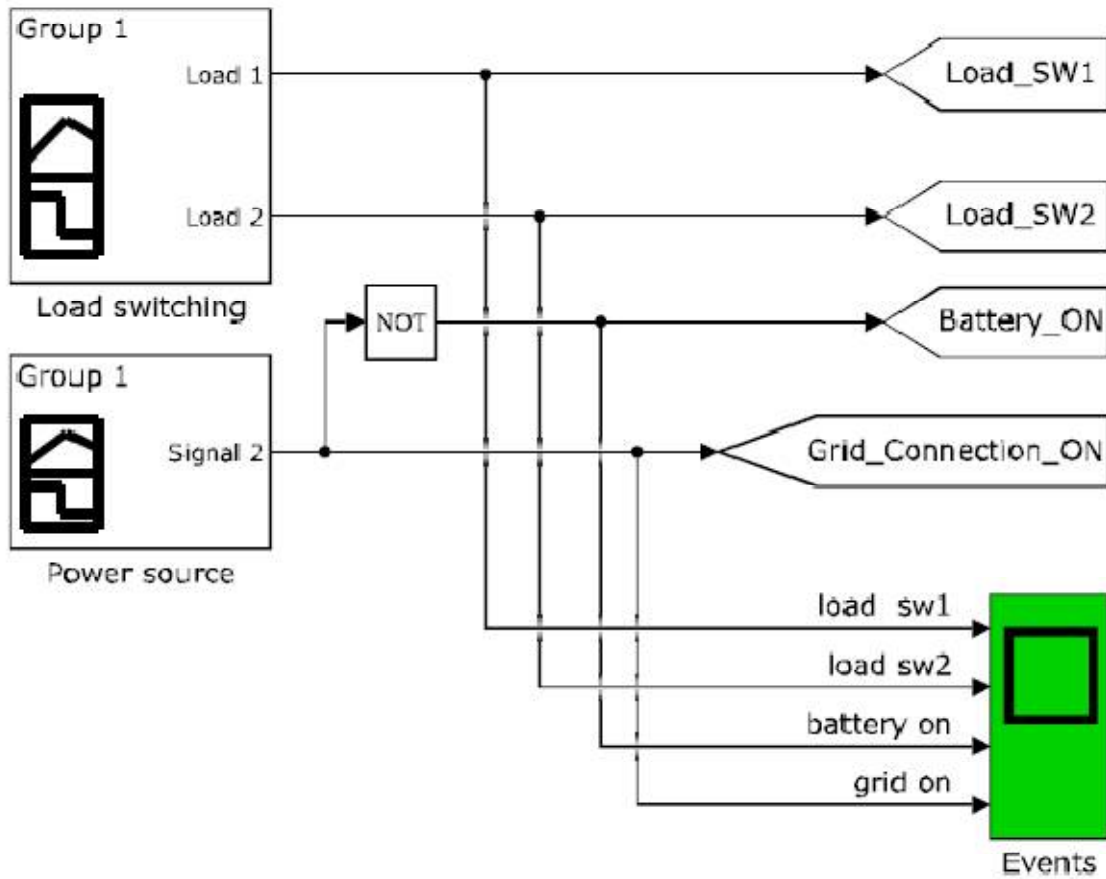

Figure 8. Simulation block of output

# International Journal of Innovative Research in Computer and Communication Engineering

(A High Impact Factor, Monthly, Peer Reviewed Journal)

Website: [www.ijircce.com](http://www.ijircce.com)

Vol. 6, Issue 5, May 2018

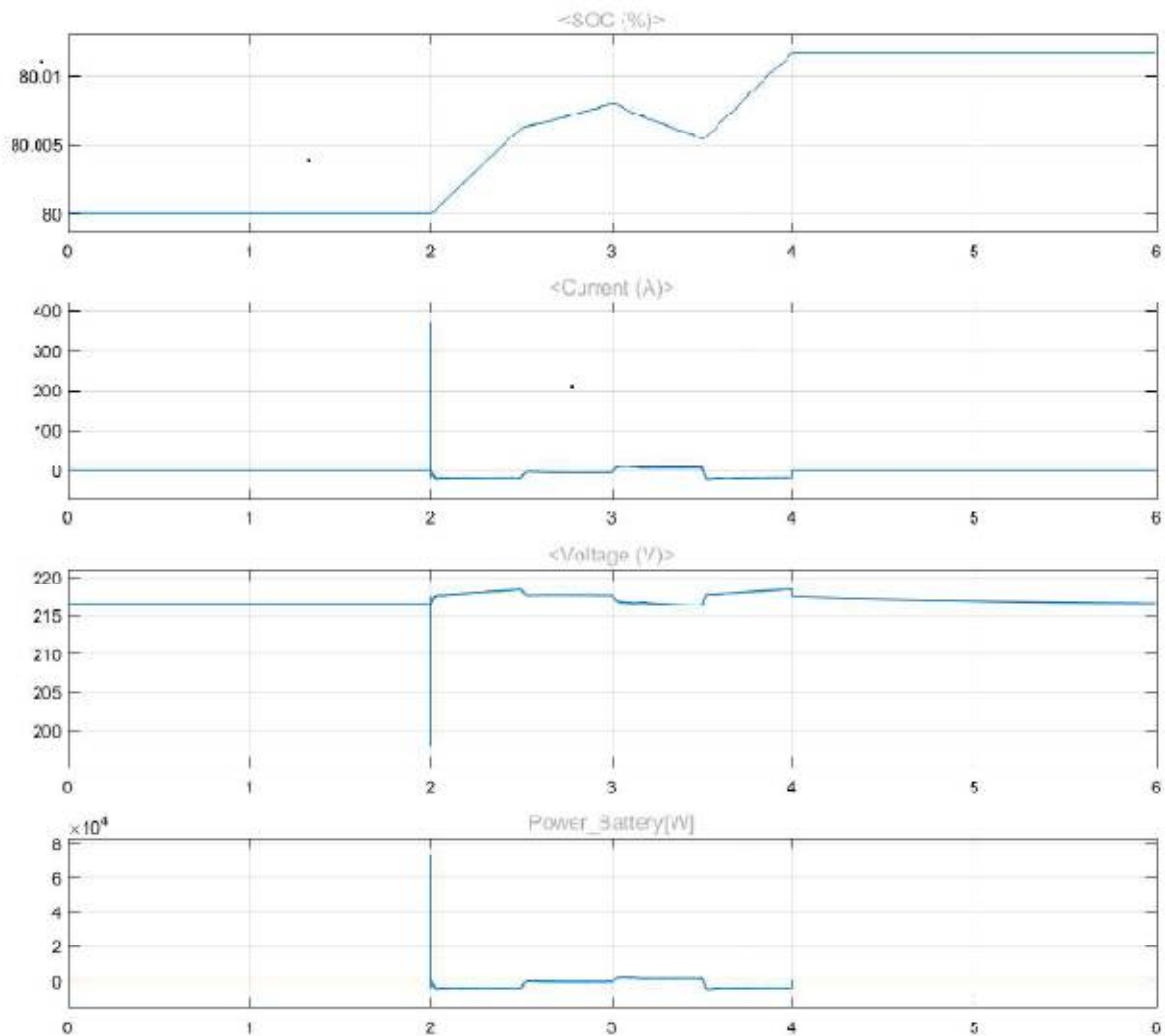

Figure 9. Detailed PV graph





# International Journal of Innovative Research in Computer and Communication Engineering

(A High Impact Factor, Monthly, Peer Reviewed Journal)

Website: [www.ijircce.com](http://www.ijircce.com)

Vol. 6, Issue 5, May 2018

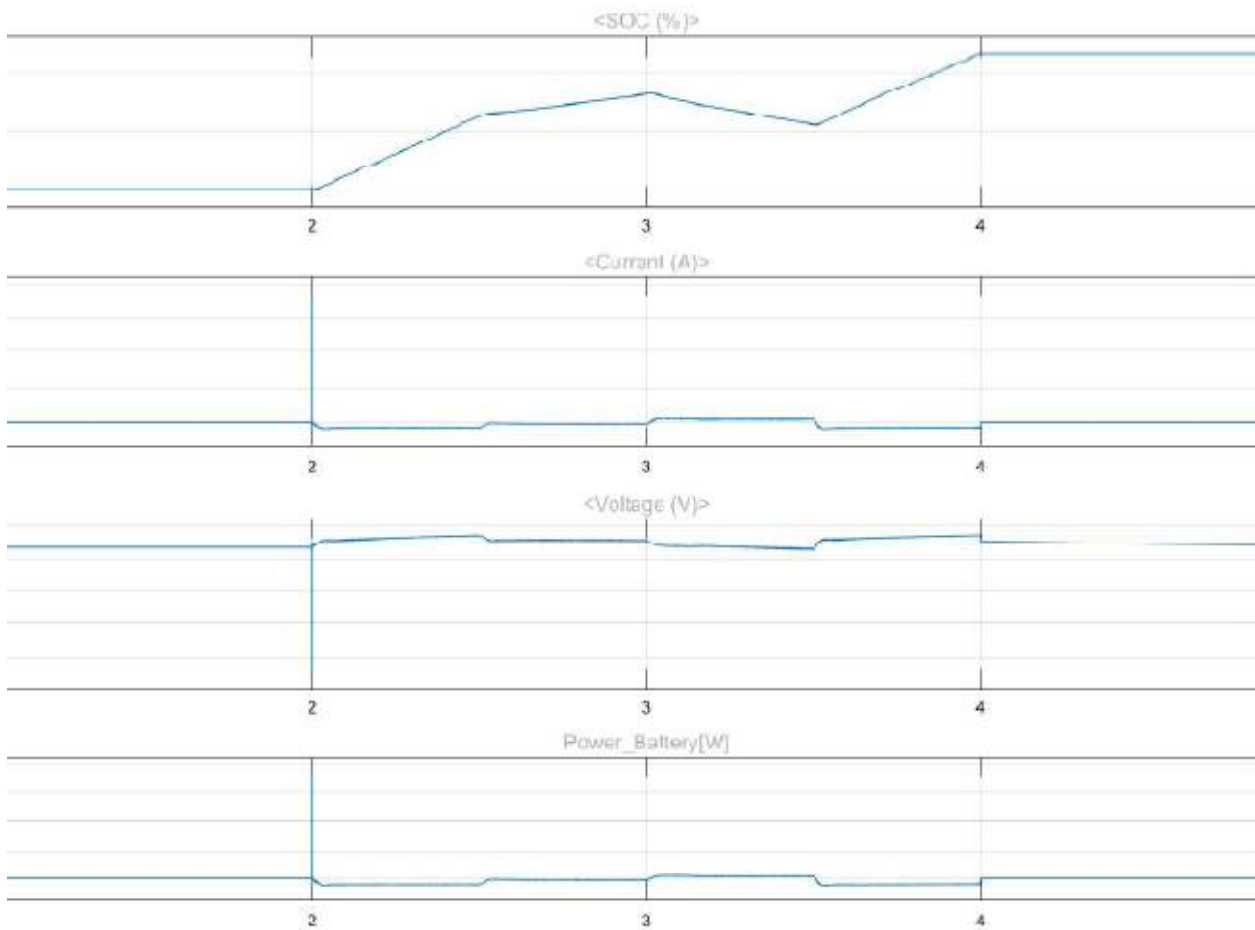

Figure 10. Battery side output

# International Journal of Innovative Research in Computer and Communication Engineering

(A High Impact Factor, Monthly, Peer Reviewed Journal)

Website: [www.ijircce.com](http://www.ijircce.com)

Vol. 6, Issue 5, May 2018

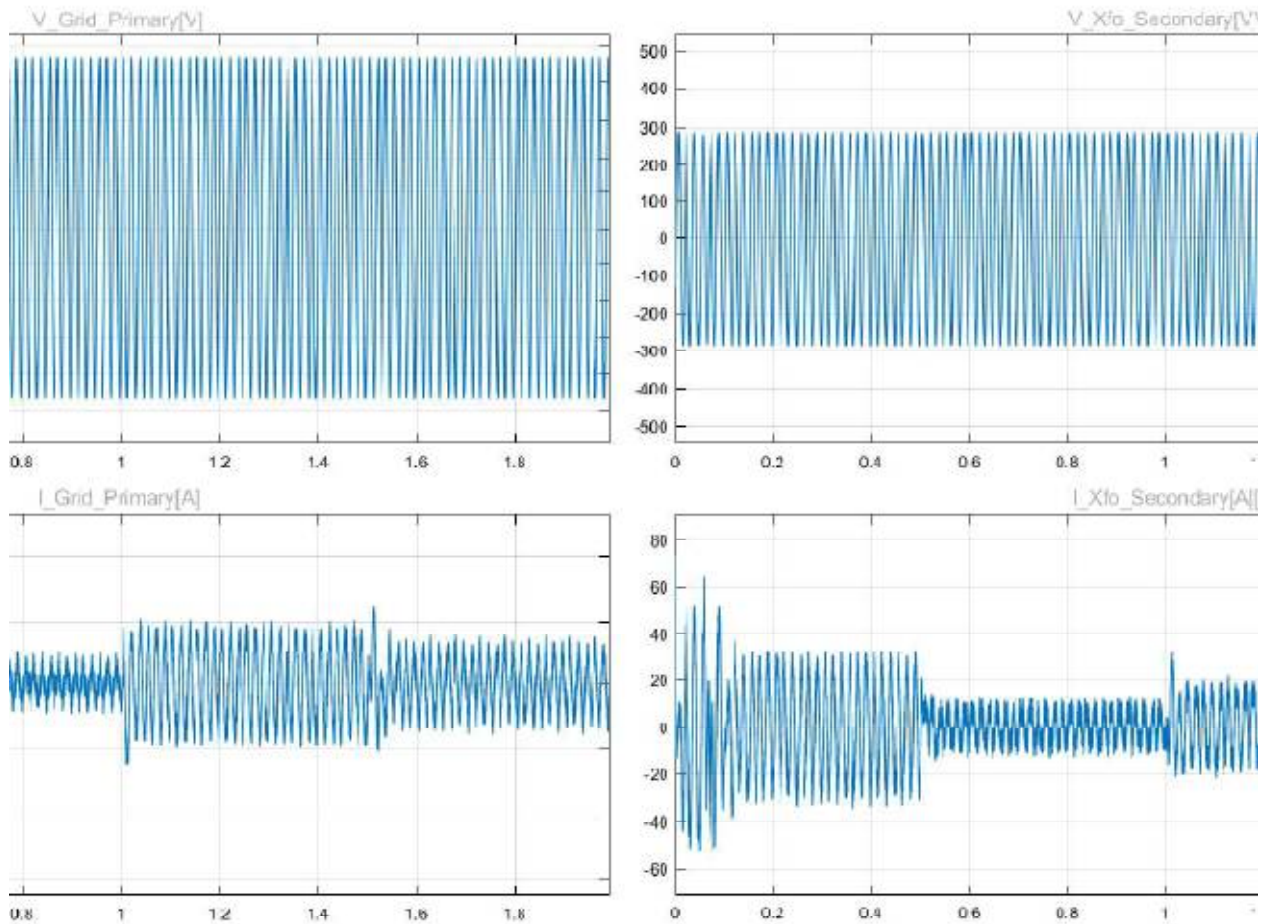

Figure .11. Grid side output



# International Journal of Innovative Research in Computer and Communication Engineering

(A High Impact Factor, Monthly, Peer Reviewed Journal)

Website: [www.ijircce.com](http://www.ijircce.com)

Vol. 6, Issue 5, May 2018

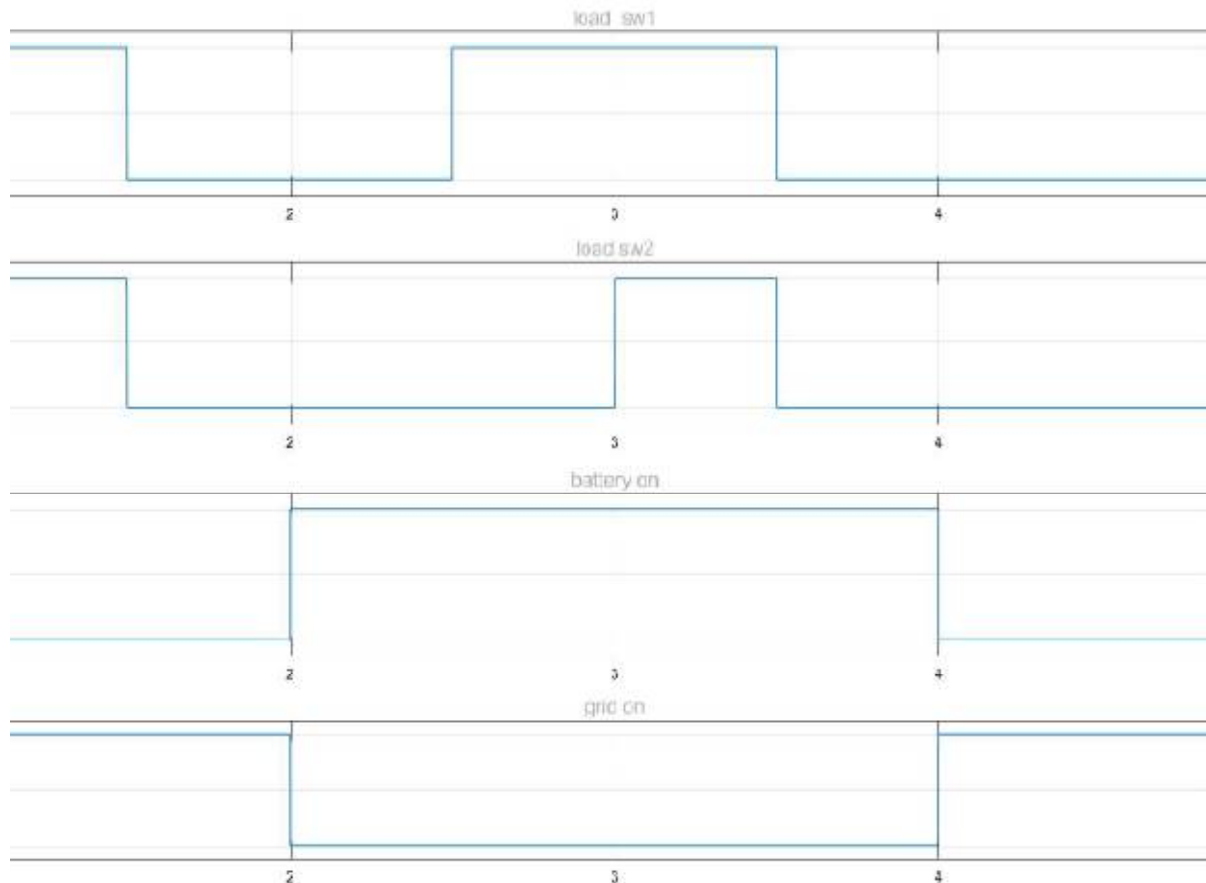

Figure .12.load, battery, grid status graph

## VII. CONCLUSIONS

In this project MPPT charge controller is implemented. Which allows the solar power system to operate optimally at all times. And also the overall operation of the buck converter was covered. The different contributions of each component were discussed and how they each affected the output and functionality of the circuit. The MPPT was discussed after the buck converter and greatly improved the tracking of the MPP. By having the ability to track the MPP, the MPPT algorithms further optimized the low efficiency solar array output. Since the solar array is the source of power to the system, any improvement in the ability to track the MPP, also greatly improves the overall system performance.

## REFERENCES

- [1] Yuxiang Shi, Student Member, IEEE, Rui Li, Member, IEEE, YaosuoXue, Senior Member, IEEE, and Hui Li, Senior Member, IEEE, High-Frequency-Link-Based Grid-Tied PV System With Small DC-Link Capacitor and Low-Frequency Ripple-Free Maximum Power Point Tracking, IEEE TRANSACTIONS ON POWER ELECTRONICS, VOL. 31, NO. 1, JANUARY 2016
- [2] Sarina Adhikari, Student Member, IEEE, and Fangxing Li, Senior Member, IEEE, Coordinated V-f and P-Q Control of Solar Photovoltaic Generators With MPPT and Battery Storage in Microgrids, IEEE TRANSACTIONS ON SMART GRID, VOL. 5, NO. 3, MAY 2014