



# **Driver Stability Detection by Monitoring the Physiological Status of the Driver Using Brain Wave Sensor**

Abitha.P<sup>1</sup>, Nimeshikka.P<sup>2</sup>, Akshaya.V<sup>3</sup>, Priyadarshini.S<sup>4</sup>, Priyadharshini.P<sup>5</sup>

Assistant Professor, Department of Information Technology, Panimalar Engineering College, Chennai, India<sup>1</sup>

UG Student, Department of Information Technology, Panimalar Engineering College, Chennai, India<sup>2,3,4,5</sup>

**ABSTRACT:** Driver stability detection by monitoring the physiological status of the driver using brain wave sensor has been proposed. In recent years, driver drowsiness has been one of the major causes of road accidents that lead to severe physical injuries, deaths and significant economic losses. In order to prevent these devastating accidents, the physiological state of the driver should be monitored. The system uses electroencephalogram (EEG) *signals* based on Brain- Computer Interface (BCI) technology. The brain waves are monitored using a brain sense head band that includes an electrode placed on the driver's forehead and a Bluetooth device that will be paired with the driver's vehicle. The EEG signals are collected and transmitted to the embedded signal processing module. Here, the embedded signal processing module, after detecting the drowsiness of the driver, triggers an alert making the vehicle to stop and thus preventing accidents.

**KEYWORDS:** Brain Computer Interface (BCI), Brain sense band, Drowsiness detection, Electroencephalogram (EEG), Physiological state.

## **I. INTRODUCTION**

Driver drowsiness has been one of the major causes of road accidents that often results in mortality. Drowsiness may lead to significant loss of control and no braking response. Hence to avoid such collisions, the driver's physiological status and mental stability is to be monitored.

To enable the detection of driver stability, various methods have been proposed. They can be categorized into two main approaches. The first is vehicle-based method (such as deviations from lane position, movement of the steering wheel, pressure on the acceleration pedal, *etc.*, are constantly monitored and any change in these that crosses a specified threshold indicates a significantly increased probability that the driver is drowsy). The second approach is behaviour-based method (such as the behaviour of the driver, including yawning, eye closure, eye blinking, head pose, *etc.*, is monitored through a camera and the driver is alerted if any of these drowsiness symptoms are detected). The major drawback seen on both vehicle based and behaviour based measures is that they become apparent only after the driver starts to sleep, which is often too late to prevent an accident.

In this study, we proposed a real-time wireless EEG-based brain-computer interface (BCI) system for driver stability detection. An electroencephalogram (EEG) is a process used to evaluate the electrical activity in the brain. Brain cells communicate with each other through electrical impulses. An EEG tracks and records the brain wave patterns. Small flat metal discs called electrodes are attached to the forehead with wires using a brain sense head band. The electrodes analyze the electrical impulses in the brain and send signals to record the results.

The proposed BCI system consists of a wireless physiological signal acquisition module in the form of a wearable head band, a signal preprocessing module and an embedded signal-processing module. Here, the wireless physiological signal-acquisition module is used to collect EEG signals and transmit them to the embedded signal-processing module wirelessly. The embedded signal processing is used to detect drowsiness and trigger a warning tone to prevent traffic accidents when drowsy state occurs.



# International Journal of Innovative Research in Computer and Communication Engineering

(A High Impact Factor, Monthly, Peer Reviewed Journal)

Website: [www.ijircce.com](http://www.ijircce.com)

Vol. 6, Issue 3, March 2018

## II. RELATED WORK

In [1] authors proposed to detect braking intentions before the driver presses the brake pedal by EEG sensors. The Lane-change intentions can also be done as the reliability of steering behaviour analysis by detecting driver fatigue. The workload/fatigue/alertness monitoring in Pilots is also done. In [2] the design and evaluation of a context-aware EEG headset system is described. The system uses a Bluetooth-enabled, EEG and gyroscope sensor-equipped headset and a machine learning model-enabled smart phone aimed to detect driver drowsiness at its early stage. This not only shifts DDD from being a reactive to a preventive driver safety technology, but also achieves a simple and inexpensive on-line analysis platform. Further studies considering an effective brainwave entrainment technology need to be performed in order to develop a real-time driver alertness boosting method. In [3] authors had modified the processing circuit that includes a conversion unit, a processing unit and a recognition unit. The conversion unit receives and converts the EEG signal into a conversion signal while the processing unit receives and processes the conversion signal to generate a processing signal that is sent to the recognition unit for generating a detection result related to the drowsiness of the body. The detection result is sent back to the micro-control circuit for output of the detection result.

## III. PROPOSED METHODOLOGY AND DISCUSSION

### A. Hardware Requirements:

- Arduino Uno
- Brain wave sensor
- Electrode
- 2 DC motors
- L293D Motor driver IC
- 2 GB RAM
- Intel Processor
- USB cable
- External battery
- Bluetooth v2.1 Class 2 (10 meters range)

### B. Software Requirements:

- MATLAB R2009a
- Arduino IDE
- Proteus software
- Languages: Embedded C

### C. Description of the Proposed Methodology:

The basic scheme of our proposed project is shown in Fig. 1. The brain wave sensor (signal acquisition phase) collects the electrical signals and brain wave patterns from the brain according to the current physiological state of the driver. These EEG signals obtained are transmitted to the PC via Bluetooth. The raw EEG signals are to be processed in order to remove the noise. The preprocessed EEG signals are transmitted to the vehicle (embedded signal-processing module). After receiving the EEG signal, it will be monitored and analyzed by our drowsiness detection algorithm implemented in an embedded signal-processing unit. If the drowsy state of the driver is detected, a warning tone device unit will be triggered to alarm the driver.

# International Journal of Innovative Research in Computer and Communication Engineering

(A High Impact Factor, Monthly, Peer Reviewed Journal)

Website: [www.ijircce.com](http://www.ijircce.com)

Vol. 6, Issue 3, March 2018

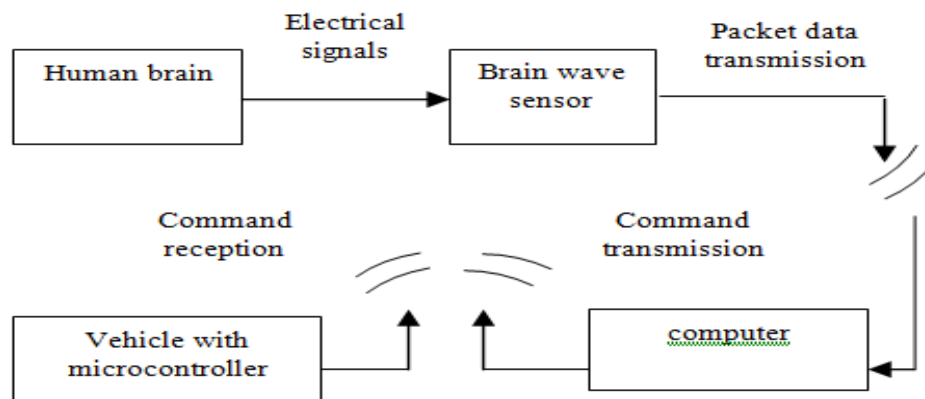

Fig.1. Framework of our proposed EEG based BCI system

## D. Module Design:

### 1. Wireless brain wave sensing band with EEG system

A wireless physiological signal acquisition module has been developed using a brain wave sensing band which constitutes of a Bluetooth device, 3 AAA batteries, an ear clip and an electrode connected with thin wires. Photograph of our wireless brain wave sensor with an electrode, a Bluetooth, batteries and an ear clip is shown in Fig.2. The reference electrode on ear clip will be beneficial to remove the ambient noises. The brain wave sensor measures and outputs the EEG power spectrums (alpha waves, beta waves, theta waves and delta waves), attention level, meditation level and the eye blink strength. During normal state of wakefulness with open eyes, beta waves are dominant. In relaxation or drowsiness alpha activity rises. Theta and delta waves correspond to deeper sleep. The drowsiness condition comes under the term Micro sleep. It is the temporary episode of sleep which may last for a fraction of seconds and it leads to fail individuals to respond at certain point and this particular point is measured by the brain wave sensor after having simulation with the hardware. The brain wave sensor has to be worn in such a manner where the electrode touches the forehead and thus EEG measures the electrical activity of the brain.



Fig.2. Photograph of our wireless brain wave sensor with an electrode, a Bluetooth, batteries and an ear clip.

# International Journal of Innovative Research in Computer and Communication Engineering

(A High Impact Factor, Monthly, Peer Reviewed Journal)

Website: [www.ijircce.com](http://www.ijircce.com)

Vol. 6, Issue 3, March 2018

## 2. Pre-processing of EEG signals

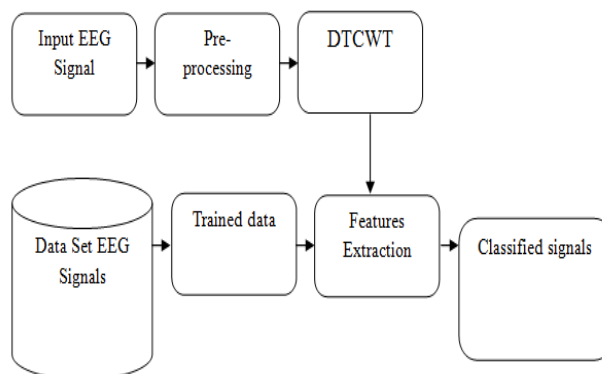

Fig.3. Data flow diagram of pre-processing and feature extraction

After signal acquisition phase, signals are to be pre-processed. Signal pre-processing is also called as Signal Enhancement. In general, the acquired brain signals are contaminated by noise. The noise includes eye blinks, eye movements, heart beats, etc. In addition to these, muscular movements and power line interferences are also mingled with brain signals. The noise removal can be done using Common Average Referencing (CAR), Surface Laplace (SL), Independent Component Analysis (ICA), Common Spatial Patterns (CSP), etc. After obtaining the noise-free signals from the signal enhancement phase, essential features from the brain signals get extracted. For feature extraction from EEG signals we use DTCWT (Dual-tree Complex Wavelet transform) to categorize the signal to low pass and high pass filter signals. The Data flow diagram of pre-processing and feature extraction is shown in Fig.3. Thus the pre-processing of EEG signals is implemented with MATLAB.

## 3. Embedded signal processing module

The embedded signal processing robotic module is connected with the backend process that uses MATLAB. Therefore, when there occurs an interrupt indicating an abnormality, the interrupt is passed on to the embedded signal processing module making the vehicle to stop.

The embedded signal processing module has been developed using an Arduino, an external battery and two DC motors. Arduino boards are able to read inputs and turn it into an output (activating a motor, turning on an LED). A set of instructions is sent to the microcontroller on the board indicating what action must be done. The board is powered with an external power supply (6 to 25 volts dc) and connected to a serial port on the computer. The program is uploaded to the Arduino board. The Arduino is connected to the MATLAB via an USB. Whenever an interrupt occurs, the control is passed to the microcontroller which stops the motor running to indicate the abnormality in the brain waves. An alarm signal is also triggered stating that the vehicle has stopped. An alarm gives an audible or visual warning of a problem or condition. Alarms have the capability of causing a fight-or-flight response in humans; a person under this mindset will panic and either flees the perceived danger or attempt to eliminate it, often ignoring rational thought in either case.

# International Journal of Innovative Research in Computer and Communication Engineering

(A High Impact Factor, Monthly, Peer Reviewed Journal)

Website: [www.ijircce.com](http://www.ijircce.com)

Vol. 6, Issue 3, March 2018

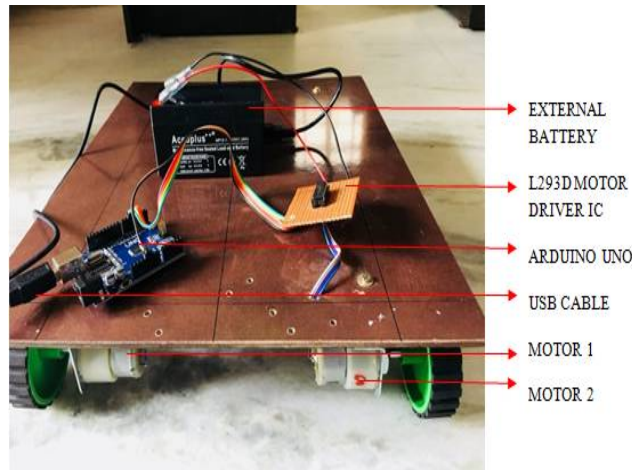

Fig.3. Photograph of our vehicle embedded with microcontroller

## IV. ALGORITHM

Step 1: Start

Step 2: Brain wave sensor band is connected to drivers head

Step 3: The brain wave sensor measures and outputs the EEG power spectrums (alpha, beta, delta and theta waves).

Step 4: The pre-processing of EEG signal is done using MATLAB.

Step 5: EEG signal is processed and given to the microcontroller.

Step 6: Microcontroller compares EEG signals with the reference signals.

Step 7: If the signal is below the reference signal vehicle is stopped by triggering an alarm indicating that the driver is in drowsy state.

Step 8: The blink rate of the driver is displayed on the PC.

Step 9: Stop

## V. SIMULATION RESULTS

The pre-processing of EEG signals is implemented with MATLAB. Use of MATLAB in the proposed system is for, data acquisition, pre-processing and simulation of the acquired signals from EEG sensor. In our proposed system, MATLAB contains the code for detecting the EEG signals from the brain wave sensor. MATLAB works as the backend process for categorizing the brain waves by acquiring the signals from the brain wave sense band via Bluetooth. MATLAB also calculates the driver's blink state and whenever an abnormality in the EEG signal is sensed, an interrupt occurs that forces the driver's vehicle to stop indicating that he is not stable. The MATLAB platform allows thinkgear dll. The proposed communication protocol is a set of simple rules to exchange the message between the computer and the EEG device. It consists of 7 basic steps, which are presented in following steps.

- Load the Think Gear library into MATLAB
- Find a new connection ID handle to Think Gear
- Attempt to connect the connection ID handle to com port "COMx"
- Wait to establish the connection
- Read packets from the connection
- Close the connection
- Unload Think Gear library

# International Journal of Innovative Research in Computer and Communication Engineering

(A High Impact Factor, Monthly, Peer Reviewed Journal)

Website: [www.ijircce.com](http://www.ijircce.com)

Vol. 6, Issue 3, March 2018

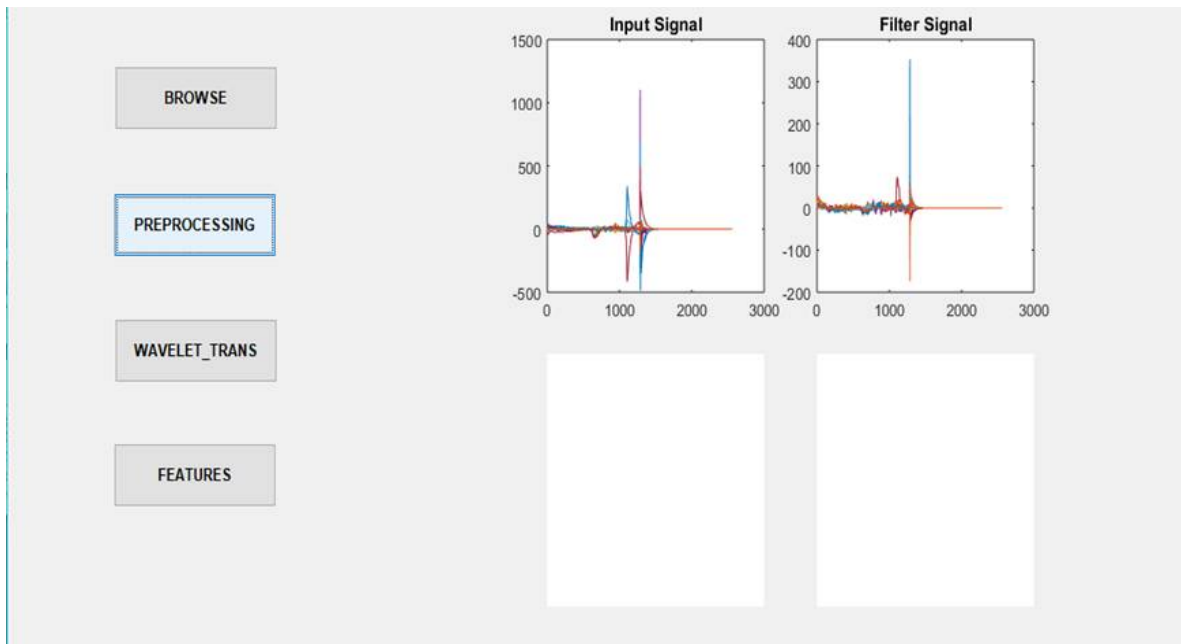

Fig.4. MATLAB simulation showing pre-processing of EEG signals.

Fig.4 shows the pre-processing of using MATLAB. A number of trained data is collected and saved separately. During MATLAB simulation, the trained data is fed by browsing them using the “browse” option. Once the trained data is selected, we use the pre-processing option for eliminating the noise (such as eye blinks, eye movements, heart beats, etc). This is visualized in fig.4 where the input signal is pre-processed and converted to a filtered signal without noise.

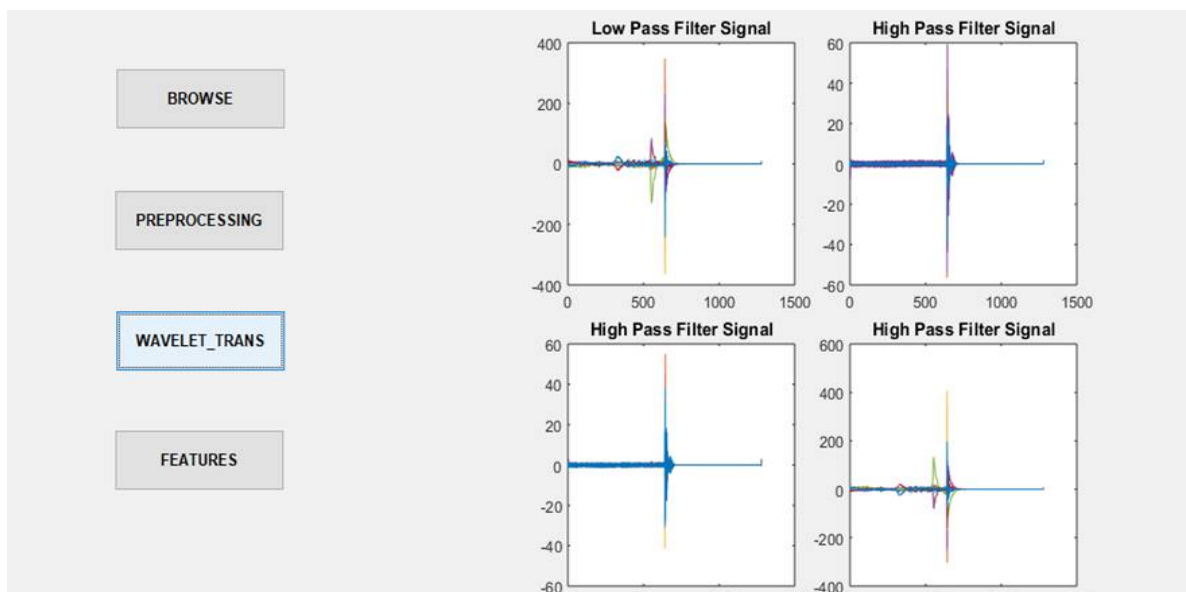

Fig.5. Feature extraction from EEG signals using DTCWT.

After the pre-processing stage, wavelet transform is carried out by using the “wavelet transform” option. Fig 5 shows



# International Journal of Innovative Research in Computer and Communication Engineering

(A High Impact Factor, Monthly, Peer Reviewed Journal)

Website: [www.ijirccce.com](http://www.ijirccce.com)

Vol. 6, Issue 3, March 2018

the wavelet transforms into low pass and high pass filters. For feature extraction from EEG signals we use DTCWT (Dual-tree Complex Wavelet transform) to categorize the signal to low pass and high pass filter signals. The dual-tree CWT is implemented as two separate two-channel filter banks. The low pass and high pass filters of one tree must generate a scaling function and wavelet that are approximate Hilbert transforms of the scaling function and wavelet generated by the low pass filter and high pass filter of the other tree as interpreted from fig.5.

## VI. CONCLUSION

In this proposed system, a real time wireless EEG-based BCI system was proposed for a driver's stability detection in a car application. It consists of a wireless and wearable EEG device, brain wave sensor band, which is comfortable to be worn in operational environment. A real-time drowsiness detection algorithm was also developed and implemented in this module to monitor the driver's physiological state continuously and trigger a warning alert when the drowsy state occurs. When compared to other BCI techniques, the setup of our BCI system is relatively easier. Therefore our real-time embedded EEG based BCI system is feasible for driver stability detection thus preventing fatal road accidents.

## REFERENCES

1. Upasana Sinha, Kamal K.Mehta and A.K. Shrivastava, "Real Time Implementation for Monitoring Drowsiness Condition of a Train Driver using Brain Wave Sensor", International Journal of Computer Applications, vol.139, pp.53-60, 2016.
2. G.Rajendra Kumar , Dr.Samuel Vara Prasada Raju and D. Santhosh Kumar, "Classification Of EEG Signals For Drowsiness Detection In Brain And Computer Interface", GESJ: Computer Science and Telecommunications, vol.No.4, pp.47-65, 2012.
3. S. Makeig, T.-P. Jung, and T. J. Sejnowski, "Awareness during drowsiness: Dynamics and electrophysiological correlates," Can. J. ExperimentPsychol., vol. 54, pp.266-273, 2000.
4. K. B. Khalifa, M. H. Bedoui, R. Raytchev, and M. Dogui, "A portable device for alertness detection", Proc. 1st Annual International IEEE-EMBS Special Topic Conference on Microtechnologies in Medicine&Biology, pp. 584-586, 2000.
5. J. Qiang, Z. Zhiwei, and P. Lan, "Real-time nonintrusive monitoring and prediction of driver fatigue," IEEE Trans. Veh.Technol., vol. 53, pp. 1052-1068, 2004.
6. C.-T. Lin, I. F. Chung, L.-W. Ko, Y.-C. Chen, S.-F. Liang, and J.-R. Duann, "EEG-Based Assessment of Driver Cognitive Responses in a Dynamic Virtual-Reality Driving Environment", IEEE Transactions on Biomedical Engineering, vol. 54, pp.1349-1352, 2007.
7. B. J. Wilson and T. D. Bracewell, "Alertness monitor using neural networks for EEG analysis", Proc. IEEE Signal Processing Society Workshop on Neural Networks for Signal Processing X, vol. 2, pp. 814-820, 2000.
8. Minoru Sakairi, "Water-Cluster-Detecting Breath Sensor and Applications in Cars for Detecting Drunk or Drowsy Driving" IEEE sensors journal, vol. 12, pp-55-78, 2012.
9. Patel M., Lal S., Kavanagh D. and Rossiter P, "Applying neural network analysis on heart rate variability data to assess driver fatigue", Expert systems with Applications, vol.38, pp- 7235-7242, 2011.
10. Grozea C., Voinescu C. D. and Fazli S, " Bristle sensors- low-cost flexible passive dry EEG electrodes for neuro-feedback and BCI applications", Journal of neural engineering, vol. 8,pp-250-275, 2011.
11. S. Roberts, I. Rezek, R. Everson, H. Stone, S. Wilson and C. Alford, "Automated assessment of vigilance using committees of radial basis function analysers," IEE Proceedings Science Measurement and Technology, vol. 147, pp. 333-338, 2000.
12. J. French, "A model to predict fatigue degraded performance," in Proc. IEEE 7th Conference on Human Factors and Power Plants, vol. 4, pp. 6-9, 2002.