



IJIRCCCE

e-ISSN: 2320-9801 | p-ISSN: 2320-9798



INTERNATIONAL JOURNAL OF INNOVATIVE RESEARCH

IN COMPUTER & COMMUNICATION ENGINEERING

Volume 11, Issue 4, April 2023

ISSN INTERNATIONAL
STANDARD
SERIAL
NUMBER
INDIA

Impact Factor: 8.379



9940 572 462



6381 907 438



ijircce@gmail.com



www.ijircce.com

Predictive Analysis of IPL Match Outcome Using RNN

Varad Pawar, Manas Yermalkar, Aditya Sathe, Deepak Mortale, Prof. C. S. Jaybhaye

Department of Information Technology, Smt. Kashibai Navale College of Engineering, Pune, Maharashtra, India

ABSTRACT:- Applications of machine learning supplemented with data mining techniques has become a hot topic for research worldwide, sports analytics is no exception though. IPL is one of the most popular sports in INDIA with a net fan base of around 2.5 billion. The game has tremendous spectator support in more than 100 nations and the masses show great interest in predicting the game outcomes. There are lots of pre-game and in-game attributes which decides the outcome of a cricket match. Pre-game attributes like the venue, past track-records, innings(first/second), team strength etc. and the various in-game attributes like toss, run rate, wickets remaining, strike rate etc. influence the result of a match in a predominant manner. We are going to predict the IPL match winning probability team using deep learning model such as recurrent neural network. Our model will be dynamic as it will take the current scenario of the match as input from the user and will show the prediction

KEYWORD:- Recurrent Neural Network, Deep Learning

I. INTRODUCTION

In India Cricket is the most loved sport and lots of work is done which predicts the result of a cricket match. This Hype has given rise to a huge market of fantasy 11 application and this project can provide a lot of importance to the model. As the Technology is growing and the fantasy 11 apps and betting sites are getting popular, people follows the prediction given by the machine learning model. Our main objective is to find the key factor that affect the match outcome and select the best model that best fits this data and gives the best results.

II. LITERATURE SURVEY

[1] Predicting Results of Indian Premier League T-20 Matches using Machine Learning (2020)

In this paper, author have studied the problem of predicting the uncertainty of who will win the upcoming IPL match based on the individual competency of each player, coordination and team work of whole team evolving and technique followed by each team in each match. In this paper author propose a model using machine learning algorithms that can predict winning team based on past data available

[2] Enhanced Predictive Modeling of Cricket Game, Duration Using Multiple Machine Learning, Algorithms (2020)

This paper implies that advertising companies have a lot of interest in the duration of a match. Indian Premier League (IPL) has a huge fan-base and is one of the major events where companies spend a large amount of money to advertise their products. Due to this, a short game, which ends prior than expected, results in loss of opportunity in terms of time-slots lost and hence revenue and fan interest. The prediction of duration of a game will be beneficial for both sport and advertisement industry. In this paper, we use machine learning algorithms to predict the duration of a match in terms of the number of balls expected to be delivered in the match. The work introduces four different approaches, using historical data, to predict the number of balls in a match.



[3] Predicting outcome of Indian Premier League Matches using Machine Learning[2020]

In this paper three types of classification were used to predict the results. Python is used as a programming language. Among the two-classification algorithm random forest gives the highest accuracy which is 89% and support vector system gives the accuracy of 66%.

[4] ICC T20 Cricket World Cup 2020 Winner Prediction Using Machine Learning Techniques (2020)

In this paper author described that, *predicting* future sounds like magic, whether it be detecting, in advance, the intent of a potential customer to purchase company's products or figuring out where the price of a stock is heading towards. If we can reliably predict the future of something, then we own a massive advantage. Machine learning has served to amplify this magic and uncover the mystery. It has also served in the fields of sports. Billions of people around the world are big fans of Cricket and wait for the results eagerly. In this paper, we discuss the 7th edition of T20 World Cup 2020 which will be held in Australia.

[5] Outcome Prediction of ODI Cricket Matches using Decision Trees and MLP Networks (2018)

In this study, 2 different ML approaches namely Decision Trees and Multilayer Perceptron Network have been used to analyze the effect produced on the outcome of a cricket match due to these varied factors. Based on these results CricAI: Cricket Match Outcome Prediction System has been developed. The designed tool takes into consideration the pregame attributes like the ground, venue (home, away, neutral) and innings (first/second) for predicting the final result of given match.

III. RESEARCH GAP

The models that are currently present for predicting the wining team or player's performance are not that accurate as some show errors or bugs while some does not execute properly. As we all know that the craze of IPL in fans and team owner to buy the players so that their team can win the trophy. So, that is why we are developing this model so that all the fans of the IPL can predict the winner of current day match and can get to know which team wins and players can get to know about their performance, their ups and downs so they can improve themselves in the upcoming matches.

IV. EXISTING SYSTEM

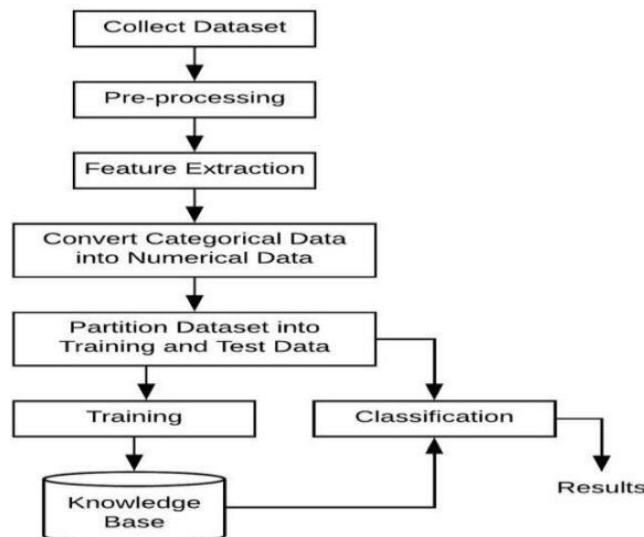

Methodology includes Dataset Collection, Pre-processing of collected dataset, Feature extraction from raw data, conversion of categorical data into numerical data, partitioning of samples into training and test samples, training and classification.

• **COLLECT DATASET**

The dataset comprises details of past 500 IPL matches. The dataset is divided into two parts Deliveries Data- dataset and Match Results- dataset. Deliveries Data-dataset contains ball by ball record of past 500 IPL matches and also includes the data dictionary associated with it. Matches Results- dataset contains extra meta-data of each match played.

• **PRE PROCESSING AND FEATURE EXTRACTION**

Collected dataset has raw data table at its initial stage which needs to be pre-processed for removing irrelevant details. Pre-processing stage cleans the dataset by removing those data that are not useful to get results. Data where results have not been declared or marked are removed during pre processing stage.

• **CONVERSION OF DATA FORMAT**

Data provided in dataset is categorical in nature due to which classification is quiet complex. So, the categorical data in dataset is converted into numeric format and normalized on scale basis.

• **TRAINING AND CLASSIFICATION**

For training and classification purpose, three predictive modeling classifiers Support Vector Machine (SVM), Naive Bayes and CTree have been used.

V. PROPOSED SYSTEM

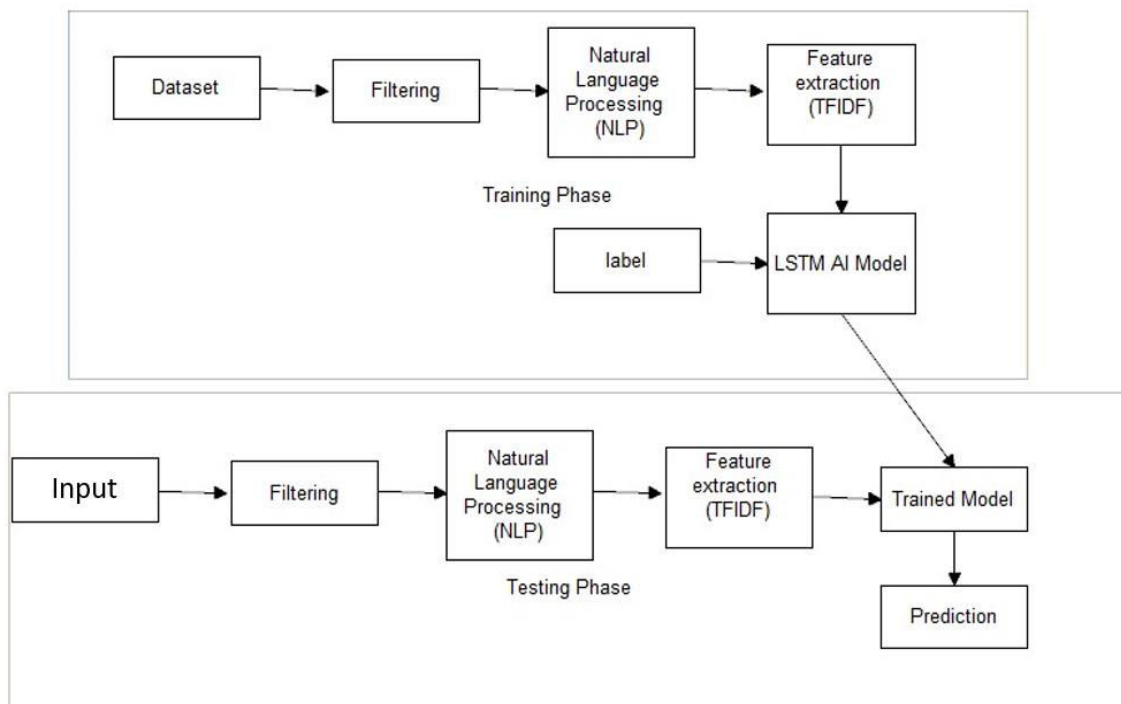

Block Diagram of Proposed System

In proposed system, we are proposing experiment on IPL cricket match prediction system with limited set of supervised data.

Deep Dense Long Short-Term Memory Network (DD-LSTM):

A powerful type of neural network designed to handle sequence dependence is called a recurrent neural network. The DD-LSTM network is a type of recurrent neural network used in deep learning because very large architectures can be successfully trained.

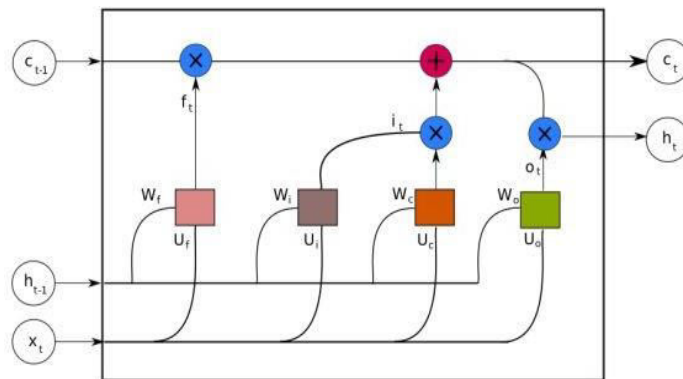

Figure : Internal Structure of long short-term memory networks

- ❑ To solve the shortcoming of regular RNNs, three gates are added to each network cell to help with memory.
- ❑ When the cell reads inputs at regular intervals, it maintains and updates a memory.
- ❑ Four gates are used in LSTMs: forget (f), input I memory (c), and output gate (o).
- ❑ The new cell memory C_t is computed as follows: Given an old memory C_{t-1} , the new cell memory C_t is computed as follows:

$$C_t = f_t * C_{t-1} + i_t * \tilde{C}_t$$

- ❑ Forget Gate: chooses whether information from the present memory should be deleted

$$f_t = \sigma(W_f x_t + U_f h_{t-1} + b_f)$$

- ❑ Memory Gate: creates a new memory candidate

$$\tilde{C}_t = \tanh(W_c x_t + U_c h_{t-1} + b_c)$$

- ❑ Input Gate: This gate controls how much of the candidate memory's data is fed into the updated memory.

$$i_t = \sigma(W_i x_t + U_i h_{t-1} + b_i)$$

- ❑ Output Gate: regulates how much memory from the cell is taken.

$$o_t = \sigma(W_o x_t + U_o h_{t-1} + b_o)$$



VI. CONCLUSION

In this work, historical data has been collected from real IPL cricket matches and useful features have been extracted after pre-processing of data. Suitable data is converted to a numeric form using term frequency and inverse document frequency. We are going to use deep learning model for prediction such as recurrent neural network. Our aim is to improve the performance of our model by using LSTM model over other machine learning model.

REFERENCES

- [1] Shilpi Agrawal, Suraj Pal Singh, Jayash Kumar Sharma, Predicting Results of Indian Premier League T-20 Matches using Machine Learning. 8th ICCS and Network Technologies: 2020.
- [2] Shivam Tyagi, Rashmi Kumari, Sarath Chandra Makkena, Enhanced Predictive Modeling of Cricket Game Duration Using Multiple Machine Learning Algorithms. International Conference on Data Science and Engineering(ICDSE): 2020.
- [3] Rabindra Lamsal and Ayesha Choudhary, Predicting Outcome of Indian Premier League (IPL) Matches Using Machine Learning. School of Computer and Systems Sciences: Jawaharlal Nehru University: New Delhi, Sep 2020.
- [4] Abdul Basit, Muhammad Bux Alvi, Tanzeel, ICC T20 Cricket World Cup 2020 Winner Prediction Using Machine Learning Techniques. 7th ed.Australia: 2020.
- [5] Jalaz Kumar, Rajeev Kumar, Pushpender Kumar .Outcome Prediction of ODI Cricket Matches using Decision Trees and MLP Networks. ICSCCC: 2018.
- [6] Aminul Islam Anik, sakib Yeaser, Player's Performance Prediction in ODI Cricket Using Machine Learning Algorithms. 4th International Conference on Electrical Engineering and Information and communication Technology: 2019



INNO  **SPACE**
SJIF Scientific Journal Impact Factor
Impact Factor: 8.379



ISSN INTERNATIONAL
STANDARD
SERIAL
NUMBER
INDIA



INTERNATIONAL JOURNAL OF INNOVATIVE RESEARCH

IN COMPUTER & COMMUNICATION ENGINEERING

 **9940 572 462**  **6381 907 438**  **ijircce@gmail.com**



www.ijircce.com

Scan to save the contact details