



IJIRCCCE

e-ISSN: 2320-9801 | p-ISSN: 2320-9798



INTERNATIONAL JOURNAL OF INNOVATIVE RESEARCH

IN COMPUTER & COMMUNICATION ENGINEERING

Volume 9, Issue 1, January 2021

ISSN INTERNATIONAL
STANDARD
SERIAL
NUMBER
INDIA

Impact Factor: 7.488

 9940 572 462

 6381 907 438

 ijircce@gmail.com

 www.ijircce.com

A Novel PTS Scheme for PAPR Reduction of Filtered-OFDM Signals

Ankita Maheshwari, Pankaj Rathi

Research Scholar, M.Tech. (Digital Communication), SITE, Nathdwara, India

Assistant Professor, Dept. of Electronics and Communication, SITE, Nathdwara, India

ABSTRACT: The mobile Worldwide Interoperability for Microwave Access (Mobile WiMAX) is a broadband wireless solution that enables the convergence of mobile and fixed broadband networks through a common wide area radio-access (RA) technology and flexible network architecture. Since January 2007, the IEEE 802.16 Working Group (WG) has been developing a new amendment of the IEEE 802.16 standard i.e. IEEE 802.16m as an advanced air interface to meet the requirements of ITU-R/IMT-Advanced for 4G systems. The mobile WiMAX air interface adopts orthogonal frequency division multiple access (OFDMA) as multiple access technique for its uplink (UL) and downlink (DL) to improve the multipath performance. The scalable OFDMA (SOFDMA) is introduced in the IEEE 802.16e amendment to support scalable channel bandwidth.

I. INTRODUCTION

In single carrier system, single carrier occupies the entire communication bandwidth but in multicarrier system the available communication bandwidth is divided by many sub-carriers. So that each sub-carrier has smaller bandwidth as compare to the bandwidth of the single carrier system. These tremendous features of multicarrier technique attract us to study Orthogonal Frequency Division Multiplexing (OFDM). OFDM forms basis for all 4G wireless communication systems due to its huge capacity in terms of number of subcarriers, high data rate in excess of 100 Mbps and ubiquitous coverage with high mobility. The introduction chapter consists of following parts: Overview, Historical Development of OFDM, principle of orthogonality, advantages and disadvantages of OFDM technique, and the applications of OFDM technique.

II. PRINCIPLE OF ORTHOGONALITY

In multi-carrier system, occupied bandwidth on the channel is minimized as possible. This minimization is possible by reducing the frequency space between carriers. The narrow space among the carriers is obtained when they are orthogonal to each other. To be orthogonal, the time averaged integral product of two signals should be zero. Mathematically, the orthogonality of two signals can be expressed as-OFDM communication systems are able to effectively utilize the frequency spectrum through overlapping subcarriers. Simulation of figure (1.1) for five sub-carriers shows that sub-carriers are able to partially overlap without interfering with adjacent sub-carriers because the maximum power of each subcarrier corresponds directly with the minimum power of each adjacent channel. In additional, different sub-carriers are orthogonal to each other and they are totally different from one another.

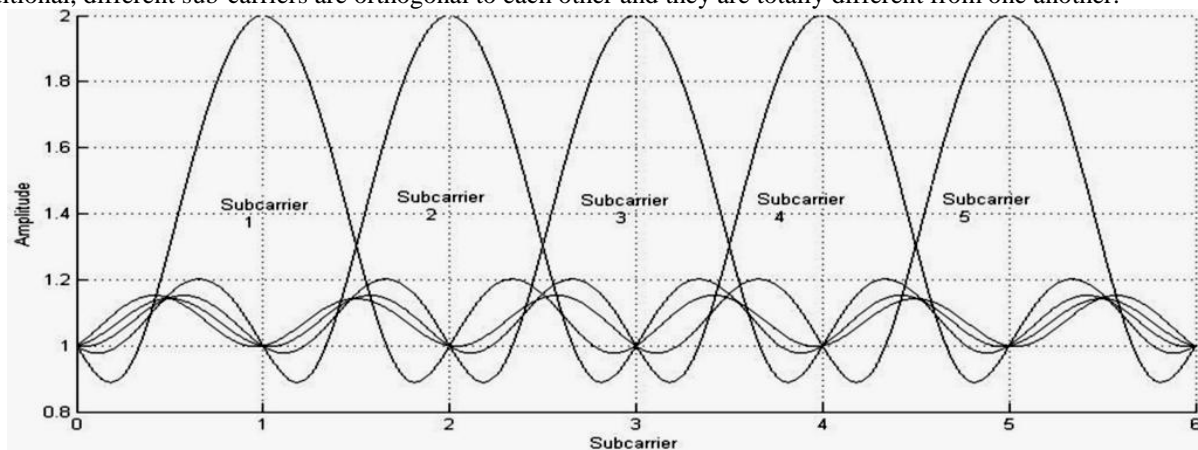

Fig. 1 Frequency response of 5 sub-carriers of OFDM signal.

Objective

The demand for higher data rate communication always provides the impetus for doing research in the OFDM field. One of the challenging issue of OFDM system is high peak to average power ratio (PAPR). High PAPR force the high power amplifier (HPA) to operate in non-linear region. This operation in non-linear region degrade the power efficiency of the amplifier simultaneously requires large back-off power, introduce ISI in OFDM system and hence, degrade the bit error rate (BER) performance. Numerous techniques have been proposed during the period of 10 years for reducing the PAPR.

III. METHODOLOGIES

The discrete time baseband OFDM system with subcarriers . It consists of transmitter, channel and receiver blocks. In this model, a block of input bits (symbols) are modulated by M-ary data modulators and then, such symbols are transferred by the serial to parallel converter. Different types of data modulator can be used depending upon system requirement (e.g. M-PSK, M-QAM etc.). The complex parallel data symbols obtained by using modulation techniques are given to point IFFT block .The complex envelope of the baseband transmitted OFDM signal can be written as-
 The mobile Worldwide Interoperability for Microwave Access (Mobile WiMAX) air interface adopts orthogonal frequency division multiple access (OFDMA) as multiple access technique for its uplink (UL) and downlink (DL) to improve the multipath performance. All OFDMA based networks including mobile WiMAX experience the problem of high peak-to-average power ratio (PAPR). The literature is replete with a large number of PAPR reduction techniques. Among them, schemes like constellation shaping, phase optimization, nonlinear companding transforms, tone reservation (TR) and tone injection (TI), clipping and filtering, partial transmit sequence (PTS), precoding based techniques, selective mapping (SLM), preceding based selective mapping (PSLM) and phase modulation transform are popular. The precoding based techniques, however, show great promise as they are simple linear techniques to implement without the need of any complex optimizations. This chapter reviews these PAPR reduction techniques and presents a Zadoff-Chu matrix transform (ZCMT) based precoding technique for PAPR reduction in mobile WiMAX systems. The mobile WiMAX systems employing random-interleaved OFDMA uplink system has been used for determining the improvement in PAPR performance of the technique. It has been further used in selective mapping (SLM) based ZCMT precoded random-interleaved OFDMA uplink system.

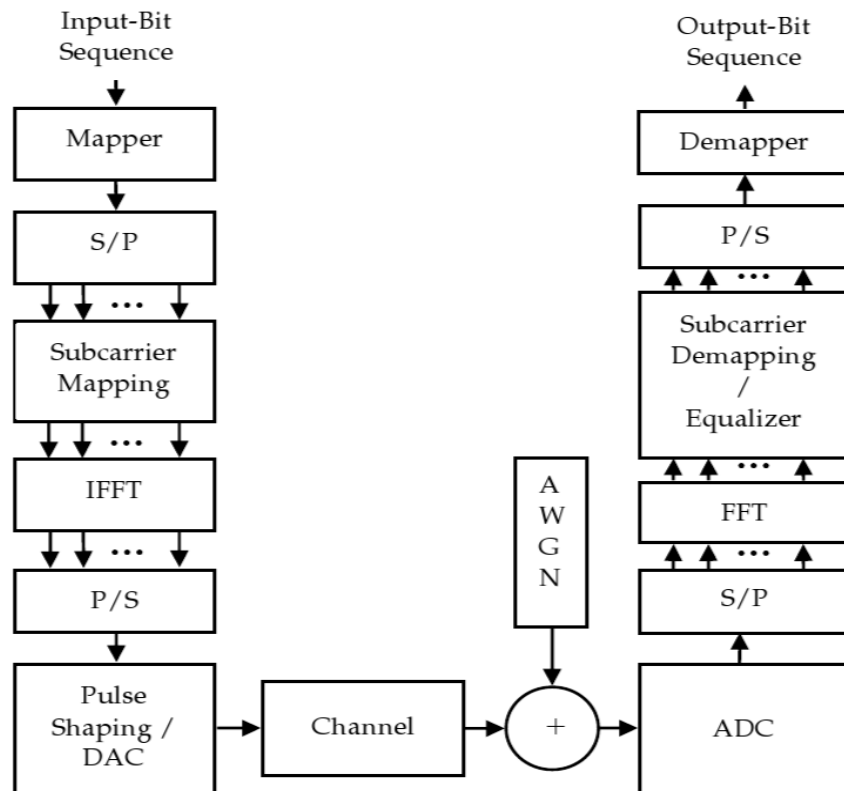

Fig. 2 Random-Interleaved OFDMA uplink system

Implementation Hybrid Technique OFDM

In this paper, a new hybrid technique is proposed to reduce the PAPR. This proposed technique is a combination of precoding and PTS methods and it is less complex than PTS method. Furthermore, it reduces the PAPR considerably with only few numbers of subblocks as compare to PTS technique. This chapter described in detail the system model and PAPR as well as power spectral density (PSD) for this model. Simulation results are done to evaluate the PAPR and PSD performance. At last, simulation results as well as conclusion is discussed.

Spectrum Shaping Filtering

The ideal raised cosine filter frequency response consists of unity gain at low frequencies, a raised cosine function in the middle, and total attenuation at high frequencies. The width of the middle frequencies are defined by the roll off factor constant Alpha, ($0 < \text{Alpha} < 1$). In Filter Solutions, the pass band frequency is defined as the 50% signal attenuation point. The group delay must remain constant at least out to 15 to 20 dB of attenuation. When the pass band frequency of a raised cosine filter is set to half the data rate, then the impulse response Nyquist's first criteria is satisfied in that the impulse response is zero for $T = NT$, where N is an integer, and T is the data period. Filter Solutions provides analog, IIR and FIR raised cosine filters. FIR are the most accurate and are best to use. However, if it is not possible to use an FIR filter, analog filters may approximate the raised cosine response. The higher the order of the filter, the greater the raised cosine approximation. High order raised cosine filters also produce longer time delays. The lower alpha values use less bandwidth, however, they also produce more ISI due to element value errors and design imperfections.

Modules

- OFDM Symbol Generation Model
- Modulation and filtering Model
- ZCT Precoding Model
- Performance Analysis

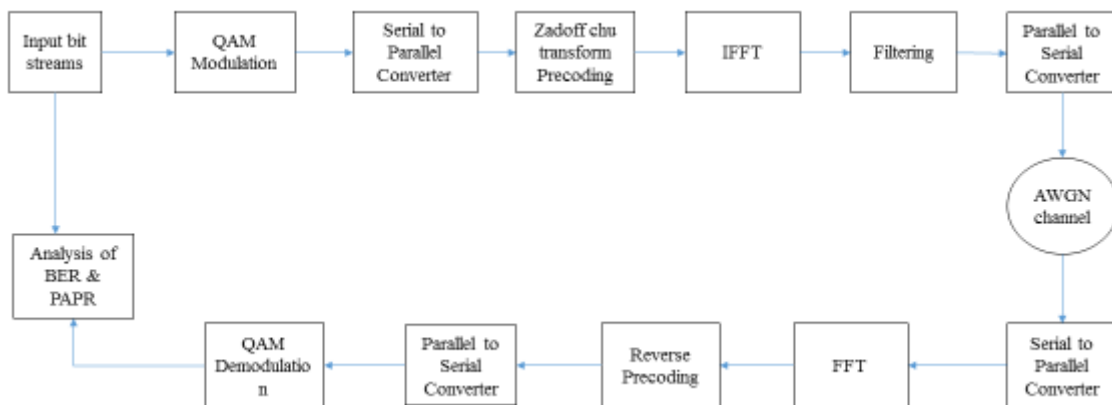

Fig. 3 Flow Diagram

IV. RESULTS AND DISCUSSION

The bit error probability is the expectation value of the bit error ratio. The bit error ratio can be considered as an approximate estimate of the bit error probability. This estimate is accurate for a long time interval and a high number of bit errors. In the case of QPSK modulation and AWGN channel, the BER as function of the E_b/N_0 is given by:

$$BER = \frac{1}{2} \text{erfc}(\sqrt{E_b/N_0})$$

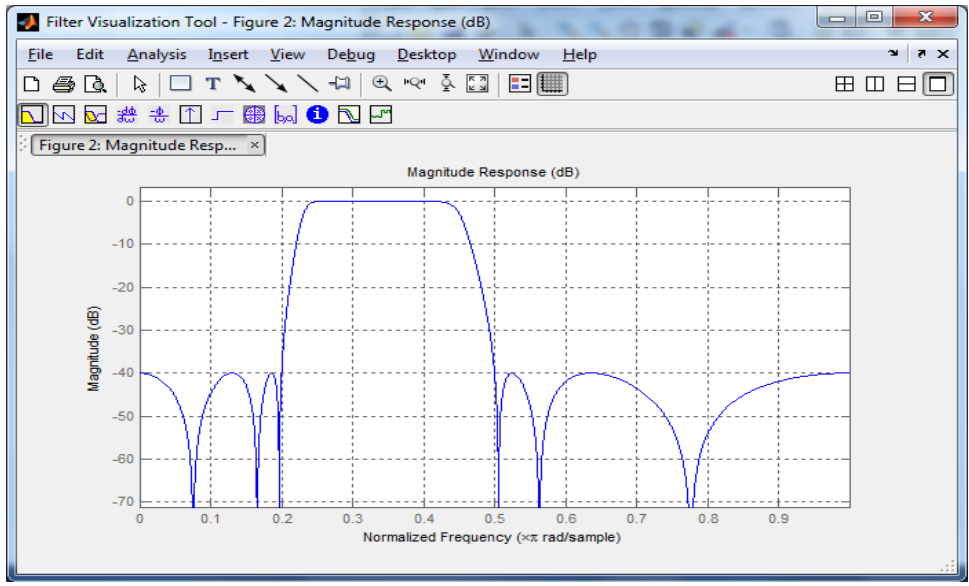

Fig. 4 Power spectral density (PSD) of proposed method.

that the proposed method has low PSD as compared to the original OFDM. roll of factor, four sub blocks as well as oversampling factor four is used for this method. Power spectral density for proposed method is approximately - 50dB/MHz and about -40dB/MHz for original OFDM. PSD has constant transmit spectrum within the range of 0.2 to 0.5MHz. From -2MHz to 0MHz and 0MHz to 2MHz show side lobes of transmit spectrum. The PSD strength within the range of -0.5 to 0.5MHz.

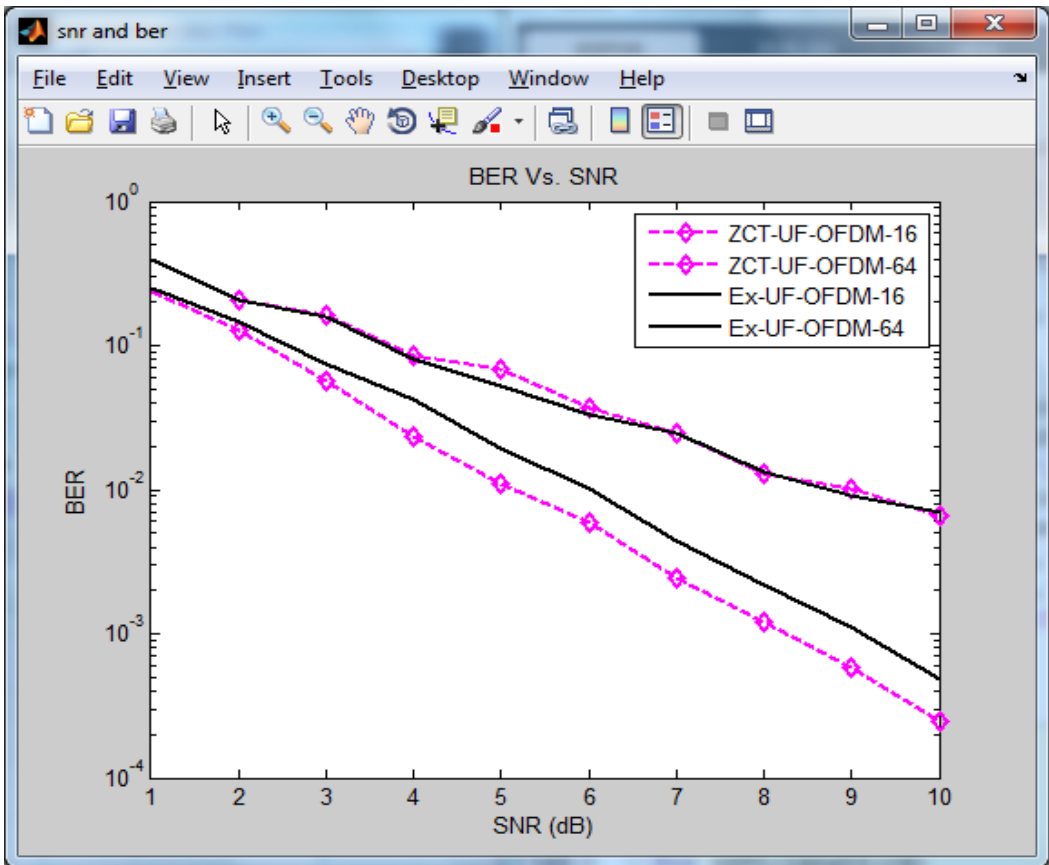

Fig. 5 BER comparison between, the EX- UF-OFDM, the ZCT-UF-OFDM and for the 16-QAM and the 64-QAM constellations

The BER performance of the EX--UFOFDM and the ZCT-UF-OFDM are compared to the ZCT- UF-OFDM for the 16-QAM and the 64-QAM constellations. As it is shown in this figure 5.2, the precoding has no effect on the BE performance in a AWGN channel. Hence, adding a precoding block to the modulation scheme improves the PAPR.

V. CONCLUSION

Thus in the proposed PAPR reduction technique using the Zadoff Chu transforms for the UF-OFDM and the F-OFDM modulation schemes was proposed. In this proposed system at first the input signal data is generated randomly and then the generated data symbols are tends to the modulation process. For that in our proposed system we use the QAM modulation. After that modulation filtering is performed. After filtering the data the signal is precoded by the ZCT precoding method and then it is passed through the AWGN channel and the reversal operations are performed.

A PAPR reduction technique for the UFOFDM and the F-OFDM modulation schemes was proposed .This technique has to keep the spectral efficiency and the BER performance of the system.

REFERENCES

- [1.] Tanairat Mata ; Pisit Boonsrimuang ; Pitchaya Boontra A PAPR Reduction Scheme based on Improved PTS with ABC Algorithm for OFDM Signal 2018 15th International Conference on Electrical Engineering/Electronics, Computer, Telecommunications and Information Technology (ECTI-CON) Year: 2018 | Conference Paper | Publisher: IEEE
- [2.] Azlina Idris ; Nur Lisa Mohd Sapari ; Mohd Syarhan Idris ; Suzie Seroja Sarnin ; Wan Norsyafizan Wan Mohamad ; Nani Fadzlina Naim Reduction of PAPR Using Block Coding Method and APSK Modulation Techniques for F-OFDM in 5G System TENCON 2018 - 2018 IEEE Region 10 Conference
- [3.] Yi-Hao Peng, Ying-Chih Kuo, Gwo-Ruey Lee, Jyh-Horng Wen, Nat.Chung Cheng Univ., Chia-Yi, —Performance Analysis of a New ICI-Self-Cancellation-Scheme in OFDM Systems, IEEE Trans 2017. vol. 53, pp.1333 – 1338.
- [4.] Thota Sravanti ; N Vasantha Precoding PTS scheme for PAPR reduction in OFDM 2017 International Conference on Innovations in Electrical, Electronics, Instrumentation and Media Technology (ICEEIMT) Year: 2017 | Conference Paper | Publisher: IEEE
- [5.] Necmi Taşpınar ; Mahmut Yıldırım A Novel Parallel Artificial Bee Colony Algorithm and Its PAPR Reduction Performance Using SLM Scheme in OFDM and MIMO-OFDM Systems IEEE Communications Letters Year: 2015 | Volume: 19, Issue: 10 | Journal Article | Publisher: IEEE
- [6.] Jun-Young Woo ; Hyun Seung Joo ; Kee-Hoon Kim; Jong-Seon No ; Dong-Joon Shin PAPR Analysis of Class-III SLM Scheme Based on Variance of Correlation of Alternative OFDM Signal Sequences IEEE Communications Letters Year: 2015 | Volume: 19, Issue: 6 | Journal Article |
- [7.] Cho, Y. S.; Kim, J.; Yang, W. Y. & Kang, C. G. (2011). MIMO-OFDM Wireless Communications with MATLAB. John Wiley & Sons, Inc. (Asia) Pte Ltd. ISBN:978-0-470-82561-7. Chu, D.C. (1972). Polyphase codes with good periodic correlation properties. IEEE Trans.Inform. Theory, vol. IT-18, pp. 531-532, 1972.
- [8.] Imran Baig ; Varun Jeoti A new ZCT precoded OFDM system with pulse shaping: PAPR analysis 2010 IEEE Asia Pacific Conference on Circuits and Systems Year: 2010 | Conference Paper | Publisher: IEEE



INNO SPACE
SJIF Scientific Journal Impact Factor

Impact Factor:
7.488

ISSN INTERNATIONAL
STANDARD
SERIAL
NUMBER
INDIA



INTERNATIONAL JOURNAL OF INNOVATIVE RESEARCH

IN COMPUTER & COMMUNICATION ENGINEERING

 9940 572 462  6381 907 438  ijircce@gmail.com



www.ijircce.com

Scan to save the contact details