



International Journal of Innovative Research in Computer and Communication Engineering

(A High Impact Factor, Monthly, Peer Reviewed Journal)

Website: www.ijircce.com

Vol. 6, Issue 3, March 2018

Automated Electricity Monitoring and Invoice System Enhanced with IoT Technology

R.V.Jayasree, S.Karunya, A.Prasanya, M.Shravya,

Assistant Professor, Dept. of Information Technology Panimalar Institute of Technology, Chennai, India

Student, Dept. of Information Technology, Panimalar Institute of Technology, Chennai, India

Student, Dept. of Information Technology, Panimalar Institute of Technology, Chennai, India

Student, Dept. of Information Technology, Panimalar Institute of Technology, Chennai, India

ABSTRACT: Recently, there have been several issues of faulty energy meter and theft of electricity. Till date, the readings are manually collected at the end of the month by a person from EB department by visiting every home. Also, the user needs to pay the electric bills either through on-line or by visiting EB offices. In this project, automated system is used to monitor the power usage and electricity billing calculating and send to user and EB via Wi-Fi management system to monitor the power consumption in a home. Here, system for energy request is automatic, don't need human effort to read the meter, client will directly know the number he needs to pay at the time

I. INTRODUCTION

EB meter reading for any energy utilization by the consumer and billing is done by meter pursuers from place to place. This requires multiple labors and long working hours to accomplish complete region information perusing and billing. Meter pursuers billing are inclined to perusing error, wrong entry of data perused. There exist accessibility bottleneck to isolated places. Likewise the consumer has no clue of energy consumed each day / week. Progresses in this path include PIC microcontroller. It is the technology of remotely gathering of energy devoured and utilizing this data in EB office for invoice generation. This technology saves power suppliers the cost of intermittent outings to each physical area to peruse a meter. This convenient data combined with analysis helped both power suppliers and consumer's better control the utilization and generation of electrical energy. Recent advancements in IC, microchip technology as empowered to create cost-effective items/products. There are diverse technologies being utilized for information exchange remotely, yet the precision, speed, productivity, reliability and cost viability are the standard advantages legitimately accomplished in this framework with an extra webapplication to see the usage of energy devoured by the customer over a period of time and generate bill automatically.

II. LITERATURE SURVEY

A. Design and Implementation of Smart Home Energy Management Systems based on ZigBee The smart energy market requires two types of ZigBee networks for device control and energy management.

B. Leveraging AMI Data for Distribution System Model Calibration and Situational Awareness Distributed energy resources such as renewable energy sources, electric vehicles, controllable loads, and electric storage are projected to become widely spread in the future. Efficient coordination of these resources requires increased monitoring and coordination at the location where they are being installed, namely the distribution system

III. SYSTEM METHODOLOGY

The proposed system is a remotely monitored energy meter with help of WiFi, IOT, PIC microcontroller, server and webpage. It visualizes overview of the proposed system. It enables distant monitoring of bill generation, and disconnection without human intervention.

International Journal of Innovative Research in Computer and Communication Engineering

(A High Impact Factor, Monthly, Peer Reviewed Journal)

Website: www.ijircce.com

Vol. 6, Issue 3, March 2018

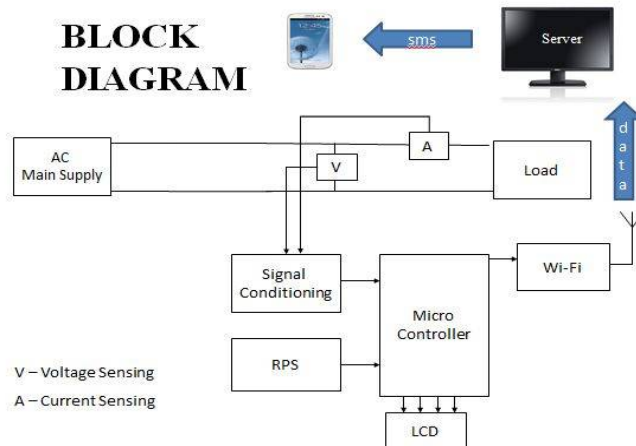

This system makes use of an PIC microcontroller that is connected to straightforward graduated digital energy meter, wireless module. Energy meter makes use of voltage and current sensors which give the measured worth as a serial output. This data is hoarded on usual within the controller memory, that is used for visualizing day-wise energy usage statistics. Associate in Nursing intelligent, simple to use application is made.

IV. SYSTEM REQUIREMENTS

The proposed work entails an underneath mentioned list of hardware and software requirements

A. HARDWARE REQUIERMENTS

1..LCD-

LCD is used to display the amount of unit used in the kit and shows the values.

CG RAM address	Bit map	Data
0000	<input type="checkbox"/> <input checked="" type="checkbox"/> <input type="checkbox"/> <input checked="" type="checkbox"/> <input type="checkbox"/>	01010
0001	<input type="checkbox"/> <input type="checkbox"/> <input checked="" type="checkbox"/> <input type="checkbox"/> <input type="checkbox"/>	00100
0010	<input type="checkbox"/> <input checked="" type="checkbox"/> <input checked="" type="checkbox"/> <input checked="" type="checkbox"/> <input type="checkbox"/>	01110
0011	<input checked="" type="checkbox"/> <input type="checkbox"/> <input type="checkbox"/> <input type="checkbox"/> <input checked="" type="checkbox"/>	10001
0100	<input checked="" type="checkbox"/> <input type="checkbox"/> <input type="checkbox"/> <input type="checkbox"/> <input type="checkbox"/>	10000
0101	<input checked="" type="checkbox"/> <input type="checkbox"/> <input type="checkbox"/> <input type="checkbox"/> <input checked="" type="checkbox"/>	10001
0110	<input type="checkbox"/> <input checked="" type="checkbox"/> <input checked="" type="checkbox"/> <input checked="" type="checkbox"/> <input type="checkbox"/>	01110
0111	<input type="checkbox"/> <input type="checkbox"/> <input type="checkbox"/> <input type="checkbox"/> <input type="checkbox"/>	00000

Connecting an LCD display to a microcontroller

International Journal of Innovative Research in Computer and Communication Engineering

(A High Impact Factor, Monthly, Peer Reviewed Journal)

Website: www.ijircce.com

Vol. 6, Issue 3, March 2018

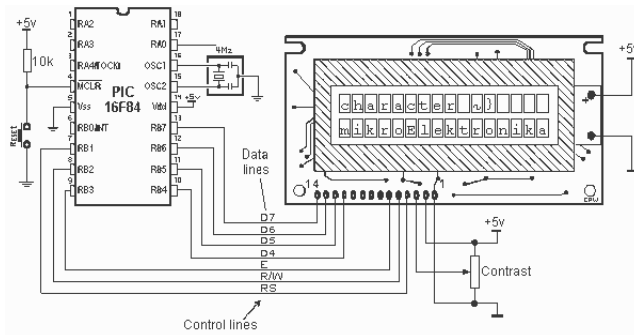

2. Signal conditioning

Signal conditioning is that the manipulation of an indication during a means that prepares it for succeeding stage of process. several applications involve environmental or structural measuring, like temperature and vibration, from sensors.

2.1. UART

A universal asynchronous receiver-transmitter isa computer hardware device for asynchronous serial communication in which the data format and transmission speeds are configurable. The electric signaling levels and methods are handled by a driver circuit external to the UART. A UART is usually an individual (or part of an) integrated circuit (IC) for serial communications over a computer or peripheral device serial port. UARTs are now commonly included in microcontrollers. A related device, the universal synchronous and asynchronous receiver-transmitter (USART) also supports synchronous operation

Serial Data Transmission

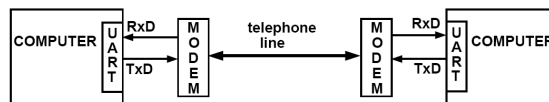

- A serial association needs fewer interconnecting cables (e.g. wires/ fibres) and thus occupies less house. the additional house permits for higher isolation of the channel from its surroundings.
- Crosstalk is a smaller amount of a difficulty, as a result of there square measure fewer conductors in proximity.

Serial versus parallel-The interface is more durable to interface than the interface. In most cases, any device you connect with the interface can would like the serial transmission regenerate back to parallel so it will be used. this could be done employing a UART.

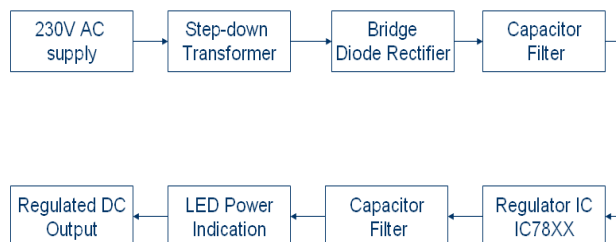

2.2. SMPS

A switched-mode power supply is an electronic power supply that incorporates a switching regulator to convert electrical power efficiently. Like other power supplies, an SMPS transfers power from a 5V or AC source (often mains

International Journal of Innovative Research in Computer and Communication Engineering

(A High Impact Factor, Monthly, Peer Reviewed Journal)

Website: www.ijircce.com

Vol. 6, Issue 3, March 2018

power) to DC loads, such as a personal computer, converting voltage and current characteristics. Unlike a linear power supply, the pass transistor of a switching-mode supply continually switches between low-dissipation, full-on and full-off states, and spends very little time in the high dissipation transitions, which minimizes wasted energy.

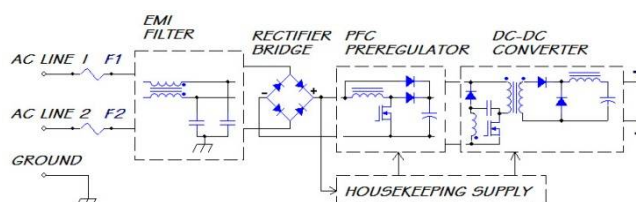

3. Regulated power supply

A DC-to-DC device is Associate in Nursing electronic circuit or mechanical device that converts a supply of electricity (DC) from one voltage level to a different. it's a kind of electrical power device. Power levels vary from terribly low (small batteries) to terribly high (high-voltage power transmission). In general, {they square measure they're not consistent and are left up to the manufacturer

4. Wi-Fi

Wi-Fi may be a remote correspondence technique for network communication of gadgets. It follows IEEE.802.11 normal that maintains scientific discipline primarily based correspondence CITY-WISE WLAN

5. Microcontroller

A microcontroller is a compact integrated circuit designed to manipulate a selected operation in Associate in Nursing embedded system. A typical microcontroller includes a processor, memory and input/output (I/O) peripherals on one chip

- For essential applications – Clock mode switch throughout operation for power savings.
- Power-Saving Sleep mode .
- Wide operative voltage vary (2.0V-5.5V).
- Industrial and Extended Temperature vary.
- Power-on Reset (POR).

The Timer0 module is Associate in Nursing 8-bit timer/counter with the subsequent features:

- 8-bit timer/counter register (TMR0)
- 8-bit prescaler (shared with Watchdog Timer)
- Programmable internal or external clock supply
- Programmable external clock edge choice

B. SOFTWARE REQUIRMENT

1. PIC microcontroller Proteus (Simulation & Circuit Design)
2. You can change your firmware in the IDE of your choice and, once compiled, test the new code on the new system at the press of a button.
3. Microsoft Visual studio 2012 (Web Application)
4. SQL server 2008 (Database) same computer or on another computer across a network (including the Internet).
5. 5.CCS (Custom Computer Service) compiler As all of other microcontrollers PIC Microcontroller can be programmed using Assembly Language. As it is little bit difficult we prefer High Level Languages. Many high level language compilers are available for programming a PIC Microcontroller like Micro C, MPLAB XC8, Hi-Tech C, CCS C etc.

VI. PROPOSED SYSTEM

EB meter reading utilized by the consumer is noted and billing is done by meter pursuers from place to place manually. This requires multiple labors and long working hours to accomplish complete region information perusing

International Journal of Innovative Research in Computer and Communication Engineering

(A High Impact Factor, Monthly, Peer Reviewed Journal)

Website: www.ijircce.com

Vol. 6, Issue 3, March 2018

and billing. Meter pursuers billing are inclined to wrong entry of data. There exist accessibility to isolated places. Likewise the consumer has no clue of energy consumed each day / week. Hence PIC microcontroller is used for gathering of energy devoured and utilizing this data in EB office for invoice generation. web application is used to see the usage of energy devoured by the customer over a period of time and generate bill automatically. Generate bill makes use of command and the reply is obtained from publish topic response of controller. Current Watt, Current Month and Previous Month makes use of command and the reply is obtained of controller.

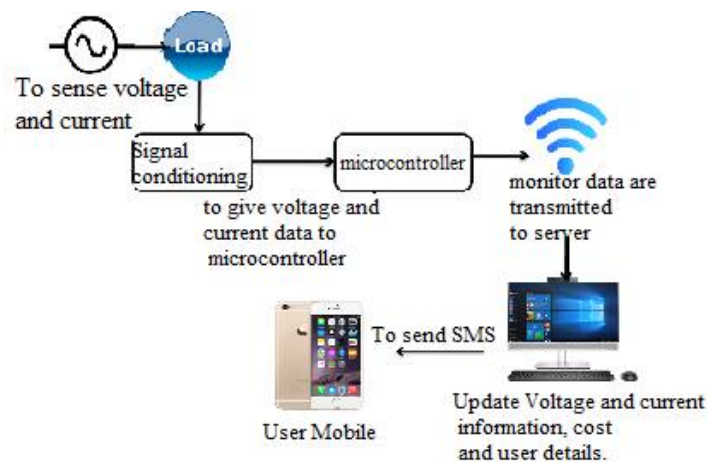

VII. MODULES

A.CALCULATION OF CURRENT AND VOLTAGE

When the AC supply is received, the system checks the supply. Accordingly the system calculates the voltage and current. Sensors are basically a device which can sense or identify and react to certain types of electrical or some optical signals. regulated power supply is used to convert unregulated AC supply into regulated DC supply. Both the data are sent to microcontroller and data are displayed in LCD. After the reading are noted in LCD the data are transmitted to server. sms are send through the wifi from server. Mobile phone will receive the sms.

B.SERVER MODULE

After the reading are noted in LCD the data are transmitted to server. SMS are send through the WiFi from server. Mobile phone will receive the SMS. This monitored data will be transmitted wirelessly using Wi-Fi to the Server. The complete information about the energy usage will be stored in server. The server will forward the usage of power alert as a message (SMS) to the user.

C.WEB APPLICATION

amount of energy used in the home and bill is generated accordingly. This web application contains details about the customers (name, date, month, meter number, data used, amount).

D.DATA RECEIVER

A receiver may be a hardware module or device accustomed receive signals of various types, betting on the context of the appliance. during this project, once the generation of the bill the bill quantity is shipped to the several client by SMS. The client refers the SMS and pays the bill.

VIII. CONCLUSION

In the epoch of digitalization, this work concentrates on connectivity and networking using IoT Technology. In many systems bill amount is sent as SMS to consumer, by this method consumer can't get the complete info about billing



International Journal of Innovative Research in Computer and Communication Engineering

(A High Impact Factor, Monthly, Peer Reviewed Journal)

Website: www.ijirce.com

Vol. 6, Issue 3, March 2018

details. The user can view month-wise load analysis curve along with current connected load data to energy meter. Hence power optimization can be achieved. Thus power usage is monitored using microcontroller and electricity bill is calculated automatically with IoT technology.

IX. FUTURE WORK & ENHANCEMENT

1. App can be created for the user to view the usage of electricity in their home.
2. The android application can append options for online payment of bill.
3. In the proposed method load analysis of single entity is performed; in future it can be boosted for area wise load analysis which will help for load forecasting.

REFERENCES

- [1] D.-M. Han and J.-H. Lim, "Design and implementation of smart home energy management systems based on ZigBee," IEEE Trans. on Consumer Electronics, vol. 56, no. 3, pp. 1417–1425, Aug. 2010.
- [2] J. Peppanen, M. J. Reno, M. Thakkar, S. Grijalva, and R. G. Harley, "Leveraging ami data for distribution system model calibration and situational awareness," IEEE Trans. on Smart Grid, vol. 6, 2015K.
- [3] P. A. Pegoraro, J. Tang, J. Liu, F. Ponci, A. Monti, and C. Muscas, "Pmu and smart metering deployment for state estimation in active distribution grids," in Proc. of IEEE ENERGYCON, 2012.
- [4] M. Simonov, G. Chicco, and G. Zanetto, "Exploiting event-driven metering to enable enhanced knowledge of electrical energy uses," in Proc. 15th IEEE Int. Conf. Environ. Elect. Eng. 2015, Rome, Italy, Jun. 10–13, 2015, pp. 1126–1131.
- [5] S. Ferg. Event-Driven Programming: Introduction, Tutorial, History Feb. 2006. [Online]. Available: <http://Tutorial.EventDrivenProgramming.ksourcforge.net>, Accessed on Jun. 1, 2016.
- [6] C. Petzold, Programming Microsoft Windows With C#. Redmond, WA, USA: Microsoft Press, 2002.
- [7] C. Petitpierre, "Synchronous C++: A language for interactive applications," Computer, vol. 31, no. 9, pp. 65–72, 1998.
- [8] Neuron C Reference Guide, Echelon, Santa Clara, CA, USA, 2009.
- [9] Y. Tsvividis, "Event-driven data acquisition and digital signal processing—A tutorial," IEEE Trans. Circuits Syst. II, Exp. Briefs, vol. 57, no. 8, pp. 577–581, Aug. 2010.
- [10] Android programming and application development. android.com /index.html
- [11] TM4C1294NCPDT microcontroller data sheet
- [12] Code composer studio <http://www.ti.com/tool/ccstudio-tm4x>
- [13] Amazon Web Service <https://aws.amazon.com/ec2>
- [14] OASIS MQTT protocol <https://www.oasis-open.org/>
- [15] SatishPalaniappan, RaghulAsokan, SrinivasBharathwaj, Sujaudeen "Automated Meter Reading System - A Study" .IJCA, April 2015
- [16] D.-M. Han and J.-H. Lim, "Design and implementation of smart home energy management systems based on ZigBee," IEEE Trans. on Consumer Electronics, vol. 56, no. 3, pp. 1417–1425, Aug. 2010.
- [17] J. Peppanen, M. J. Reno, M. Thakkar, S. Grijalva, and R. G. Harley, "Leveraging ami data for distribution system model calibration and situational awareness," IEEE Trans. on Smart Grid, vol. 6, 2015K.
- [18] P. A. Pegoraro, J. Tang, J. Liu, F. Ponci, A. Monti, and C. Muscas, "Pmu and smart metering deployment for state estimation in active distribution grids," in Proc. of IEEE ENERGYCON, 2012.
- [19] M. Simonov, G. Chicco, and G. Zanetto, "Exploiting event-driven metering to enable enhanced knowledge of electrical energy uses," in Proc. 15th IEEE Int. Conf. Environ. Elect. Eng. 2015, Rome, Italy, Jun. 10–13, 2015, pp. 1126–1131.
- [20] S. Ferg. Event-Driven Programming: Introduction, Tutorial, History Feb. 2006. [Online]. Available: <http://Tutorial.EventDrivenProgramming.ksourcforge.net>, Accessed on Jun. 1, 2016.
- [21] C. Petzold, Programming Microsoft Windows With C#. Redmond, WA, USA: Microsoft Press, 2002.
- [22] C. Petitpierre, "Synchronous C++: A language for interactive applications," Computer, vol. 31, no. 9, pp. 65–72, 1998.
- [23] Neuron C Reference Guide, Echelon, Santa Clara, CA, USA, 2009.
- [24] Y. Tsvividis, "Event-driven data acquisition and digital signal processing—A tutorial," IEEE Trans. Circuits Syst. II, Exp. Briefs, vol. 57, no. 8, pp. 577–581, Aug. 2010.