



International Journal of Innovative Research in Computer and Communication Engineering

(An ISO 3297: 2007 Certified Organization)

Website: www.ijirccce.com

Vol. 5, Issue 3, March 2017

An Advanced ATM Crime Prevention System

Shubham Patil¹, Mayuri Balure², Prof. S.D. Panchal³

B.E. Student, Dept. of Electronics & Telecommunication, Sandipani Technical Campus, Latur, India¹

B.E. Student, Dept. of Electronics & Telecommunication, Sandipani Technical Campus, Latur, India²

Asst. Professor, Dept. of Electronics & Telecommunication, Sandipani Technical Campus, Latur, India³

ABSTRACT: Our proposed system will provide advanced ATM theft security system. The Afflatus for our project is gained from the news and issues which are happening in our daily life. Now a day's larceny or robbery of ATM is superabundantly increased so due to that we trying to disclose remedy for it. Keeping the technique of keep it simple in our mind, we recommended advanced ATM crime prevention system for ATM machine, starting from sensors at the entrance to GPS technology in the ATM machine. Followed by the smart unauthorized access detection and informed to the nearest police station and the bank authority.

KEYWORDS: GSM Module, Vibration System, Tilt Sensor, ATM security.

I. INTRODUCTION

We belong to the edge of digitized and smart world. People are getting smarter day by day with the help of new technology, new innovations. Main reason behind the up gradation of new technologies is nothing but to overcome the existing problems. Economic growth of world makes the life smarter and better as compared to previous lifestyle. A smart step towards economy is the introduction of automated teller machine (ATM), for faster and easier money transfer. But a group of people do malpractices over this ATM system to put people, organization or bank into a millions pounds of loses.

This system proposed in our project, maintain the entry of a single card holder at a time with the help of auto sensor detection. Follows by the vibration detection and GPS technology used in the ATM Machine. If any types of unexpected events occurred, nearest police station and the authority will be informed automatically.

II. LITERATURE OVERVIEW

In 1975, Korea exchange bank introduced the first ATM, followed by Shinhan bank in 1982, According to ATM industry Association (ATMIA). There are now close to 2 million ATM in this World ^[1].

Currently, the ATM machines are not secured that much. Those are only having the card swapping facility ^[2] at the entrance at the door. But this facility doesn't control the number of users entered at a particular instance. Number of ATMs are also covered under this system are also very few. Another proposed secured system is to place vibration sensor ^[3] into the ATM machine. But if the complete machine is stolen then it has not that much physical use. For that situation we need a tracking device on that machine, which is not in use yet. ATM robbery and fraud occurrence is noticeable increase in last few years.

International Journal of Innovative Research in Computer and Communication Engineering

(An ISO 3297: 2007 Certified Organization)

Website: www.ijirccce.com

Vol. 5, Issue 3, March 2017

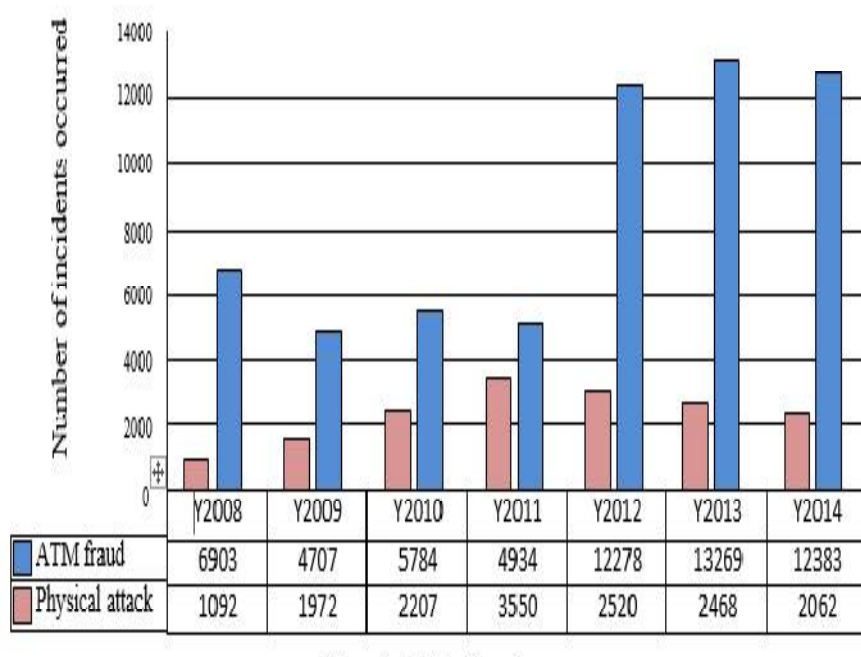

Figure 1: ATM robbery in per year

This project will help to fix all this vital issues with the help of some advanced sensors^[4] and global positioning system (GPS)^[5].

III. OBJECTIVES

- To overcome the ATM theft.
- Restrict the entry of any unauthorized person.
- Provide more security.
- Formal step towards smart city.

IV. WORKING OVERVIEW

- **Sensor on the Machine :**
 - Vibration Sensor: Vibration sensor will sense any type of the unwanted hit or attack on the metallic machine, and alarm will be started.
 - Tilt Sensor: Any type of moment by the ATM machine will sense in this sensor, due to unwanted proceedings the alarm will be started.
- **GSM System :**
 - GSM system will work at the most highest security level.
 - If any kind of misplace of ATM machine is occurred, the GSM system will automatically sends the message to the nearest Police Station and the Bank Authority. They will take the suitable action.

International Journal of Innovative Research in Computer and Communication Engineering

(An ISO 3297: 2007 Certified Organization)

Website: www.ijirccce.com

Vol. 5, Issue 3, March 2017

V. HARDWARE RESOURCES

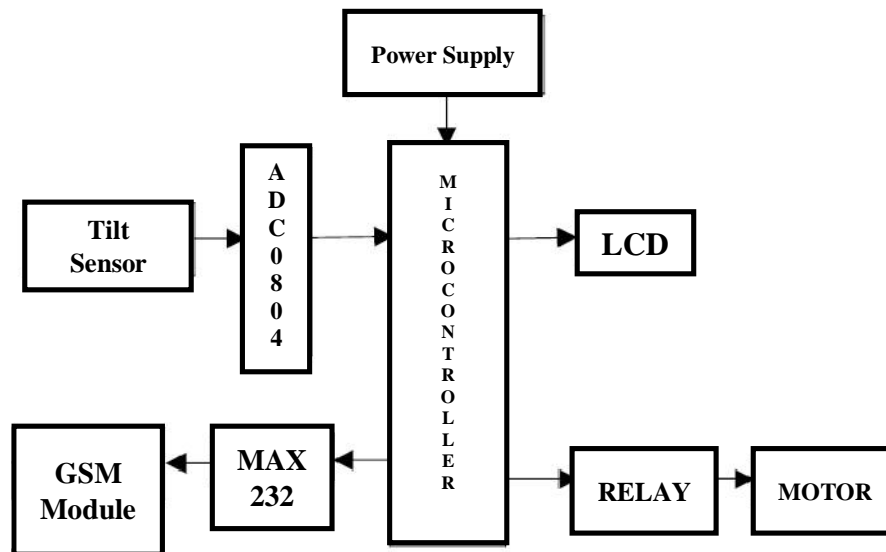

Figure 2: Block Diagram of System

- A. Microcontroller:** A microcontroller can be compared to a small stand-alone computer; it is a very powerful device, which is capable of executing a series of pre-programmed tasks and interfacing with other hardware devices. Being packed in a tiny integrated circuit (IC) whose size and weight is usually negligible, it is becoming the perfect controller for robots or any machines requiring some kind of intelligent automation. A single microcontroller can be sufficient to control a small mobile robot.
- B. Power Supply Circuit:** The main building block of any electronic system is the power supply to provide required power for their operation. For the microcontroller keyboard, LCD, GSM, +5V are required & for driving buzzer +12V is required. The power supply provides regulated output of +5V & non-regulated output of +12V. the hardware part consists of the components and the sensors used in the system. This system mainly collects the status of the sensors and stores it into the micro controller's EEPROM.
- C. LCD (Liquid Crystal Display):** LCD screen is an electronic display module and find a wide range of applications. A 16x2 LCD display is very basic module and is very commonly used in various devices and circuit.
- D. DC Motor:** For the closing the ATM door, we are using DC Motors. It is operated by 12V DC power supply. In any electric motor, operation is based on simple electromagnetism.
- E. L293D Driver:** L293D driver is dual H-Bridge motor driver integrated circuit (IC). Motor drivers act as current amplifiers since the take a low-current control signal and provide a higher-current signal. This higher current signal is used to drive circuits.
- Features:**
- Wide supply-voltage range: 4.5V to 36V.
 - Output Current 1 A per Channel (600mA for L293D)
 - Peak Output Current 2 A per Channel (1.2A for L293D)
- F. Buzzer:** Piezo buzzer is an electronic device commonly used to produce sound. Light weight, simple construction and low price make it usable in various applications like car/truck reversing indicator, computer, call bells etc.



International Journal of Innovative Research in Computer and Communication Engineering

(An ISO 3297: 2007 Certified Organization)

Website: www.ijirccce.com

Vol. 5, Issue 3, March 2017

VI. CONCLUSION

As we all know, these days most of the ATMs have been attacked by the robberies. From the first ATM being installed in the world till now, ATM has gradually become a target of crimes. While with the constantly evolving of reported ATM crime ATM industry has begun to pay attention to the safety of ATM, even cardholders. This paper demonstrates how an automation of ATM crime prevention can be implemented using GSM technology, 8051 microcontroller, Tilt Sensor, DC Motor, Buzzer with KEIL Micro Vision 4.0 in ATM Machines Centre. By implementing this project we can easily prevent the crime and also we can save our precious time.

REFERENCES

- [1] http://en.wikipedia.org/wiki/Automated_teller_machine
- [2] M. Ajaykumar & N. Bharath Kumar, "Anti-Theft ATM Machine Using Vibration Detection Sensor", December 2013
- [3] Sivakumar T, Gajjala Askok & K. Sai Venuprathap, "Design and Implementation of Security Based ATM Theft Monitoring System", August 2013.
- [4] Jason Hill and David Culler "A wireless embedded sensor architecture for system-level optimization".
- [5] https://en.wikipedia.org/wiki/Global_Positioning_System

BIOGRAPHY



Shubham Patil is Final Year student in the Electronics & Telecommunication, Sandipani Technical Campus, Latur. Currently, He is doing his BE Project in "An Advanced ATM Crime Prevention System". His areas of interests are Robotics, C language Programming and Mathematics. He has won Gold Medal in Zonal Robotics Championship and also participated in National Robotic Championship held at IIT BOMBAY.



Mayuri Balure is Final Year student in the Electronics & Telecommunication, Sandipani Technical Campus, Latur. Currently, She is doing his BE Project in "An Advanced ATM Crime Prevention System".



Prof. S.D. Panchal is an Assistant Professor and H.O.D. in the Electronics & Telecommunication Department, Sandipani Technical Campus, Latur. He is an expert in Embedded System and VLSI. He has more than 5 years of experience in these fields.