



International Journal of Innovative Research in Computer and Communication Engineering

(An ISO 3297: 2007 Certified Organization)

Website: www.ijircce.com

Vol. 5, Issue 10, October 2017

An Arduino Based Systematic Approach to Trap Carnapper

Vishnu C R¹, Surag M T¹, C. Raseek²

U.G. Student, Dept. of Computer Science, Govt. Engg. College, Palakkad, Kerala, India¹

Asst. Professor, Dept. of Computer Science, Govt. Engg. College, Palakkad, Kerala, India²

ABSTRACT: The proposed system is very much useful in the increasing vehicle robberies of the world. This system has been implemented with Arduino, Global Positioning System(GPS) and Global system for mobile communication (GSM) technology, with a relay in order to stop the vehicle and android phone application in order to provide a user friendly environment. In addition to this a trapping and locking system is implemented. Trapping system is an internal ring gear attached with a DC motor which lock the driver in the seat and don't let him escape. The locking system is a rack and pinion arrangement with a DC motor, installed inside the door by making a hole. In this advanced world simple tracking system is not effective, by chance we reach the vehicle there is a chance to the escape of the thief. We can't control these robberies if the thief is escaped. This system is helpful to give real punishment to the intruder. In such a situation everything set in a simple mobile application in a cost effective way is very convenient for the user.

KEYWORDS: Tracking, Arduino, GPS, GSM, Real Time Systems

I. INTRODUCTION

In the last few decades, there was a tremendous increase in the number of vehicles as well as the crimes related to the vehicles. One of the main crime was vehicle theft. According to the news report published by The Times of India [1] a vehicle is stolen every 13 minutes in Delhi. This value is based on the crime reported in just three months and this value is about 44% greater than the previous year. The fact is that only 4% vehicles are recovered. The situation is not different in other places. So it is clear that, The proper vehicle security system is much needed.

There are so many researches occurring in this field. So many persons have written their papers. In 2011, a design and implementation of vehicle tracking system using GPS [2] has been Reported. This system makes use of GSM/GPRS technology to establish the communication between the system and tracking server. In [3] a tracking system was proposed. The same GPS and GPRS modem are used and it is controlled by ARM7 LPC2148. Which is a 32 bit micro controller. This work was in 2013. In the same year another work reported that was vehicle tracking and locking system based on GPS and GSM [4]. That was a good, advanced system, able to lock the engine and the door and require a password to reset it. A design and implementation of vehicle tracking system using GPS/GSM/GPRS technology and smart phone application [5] was reported in 2014. They illustrated the functionality of tracking with smart phone application. So the user can easily perform the tracking. In 2014 itself, a system for tracking and monitoring system [6] was proposed. This system was implemented with ARM processor and able to track, sense temperature, detect alcohol and face, etc. The main purpose of this system is monitoring rather than tracking. In 2015, two vehicle tracking systems [7], [8] using GPS/GSM/GPRS technology and smart phone application were designed and implemented. A system [9] that aims to provide a low cost means of monitoring a vehicle's performance and tracking by communicating the obtained data to a mobile device via Bluetooth. A real time Google map and Arduino based vehicle tracking system [11] were reported in 2016. This system is user friendly and ensures safety and surveillance at low maintenance cost. These all are some researches in the field. The main objective of this work is to provide a proper system to recover the vehicle and trap the thief.

This work is able to perform multiple functionalities. Track, stop the vehicle, lock the door and trap the thief in the seat. The advancement in the satellite technology made the vehicle tracking easy. This can be easily done by GPS shield attached with micro controller, here Arduino. And the communication is established through GSM technology.

International Journal of Innovative Research in Computer and Communication Engineering

(An ISO 3297: 2007 Certified Organization)

Website: www.ijircce.com

Vol. 5, Issue 10, October 2017

There is an additional lock added to the door which is only operated by mobile. This is installed by making holes in the side of doors. The locking system cannot be hacked simply. Sometimes Locking only can trap the thief, there is a chance to break the glass and escape. In order to trap the thief completely there is a special seat belt like lock also added. If there is no mechanism to lock the door any third party can help him, since the locking system cannot be opened without registered mobile phone no one else can help the thief. All these functionalities will be useful if the intruder is inside the car, to ensure that we use a vibration sensor. Totally, the recovery processes have been simplified and also the vehicle theft can be decreased by giving proper punishments.

II. OBJECTIVE

1. The objective of the project is tracking of the vehicle and trap the driver inside the car in case of any odd situation
2. Provide a permanent solution to the increasing car theft in a cost effective way.
3. Easy to use environment with advanced functionalities.
4. Clear all the possibilities of the intruder to escape from the vehicle

III. SYSTEM OVERVIEW

The main system contains different subsystems, which includes locking system, trapping system. The hardware part of the system is installed in the vehicle and the software is in the android phone. The connection between subsystems and the components in the subsystem is as in Fig.1.

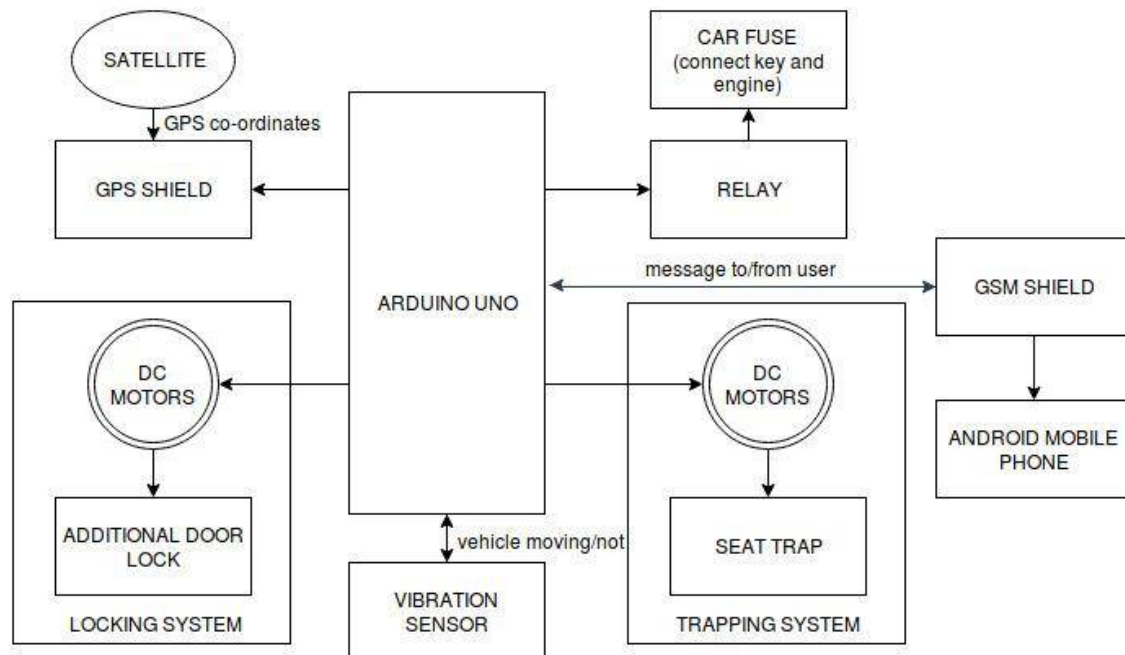

Fig.1 Illustrate the overall block diagram of the system. The Arduino UNO is the brain of system and there is a GSM shield in order to establish the communication with owner's phone where all controlling and management takes place. Both the locking and trapping system contains DC motor. The vibration sensor is used to ensure the vehicle is in motion so that the driver will be in driving seat and trapping can be done effectively. In order to stop the vehicle there is a relay connected with the fuse connecting car key and ignition system.

International Journal of Innovative Research in Computer and Communication Engineering

(An ISO 3297: 2007 Certified Organization)

Website: www.ijirccce.com

Vol. 5, Issue 10, October 2017

IV. HARDWARE SPECIFICATION

- *Arduino Micro-controller*
Arduino UNO is a microcontroller board based on the Atmega328P, works as brain of the system. This act as the interface for the shields and the motor. A program written in c programming language, compiled and stored into the flash memory of microcontroller.
- *Arduino-GSM Shield*
The Arduino GSM Shield 2 allows an Arduino board to connect to the Internet, make/receive voice calls and send/receive SMS messages. This is responsible of establishing connections between a tracking system and mobile phone. On its own, this shield can't do anything. It requires a micro-controller like an Arduino to drive it and Additionally a SIM Card with cellular connectivity.
- *Arduino GPS Shield*
Global Positioning System is a network of orbiting satellites that send precise details of the position in space back to earth. So GPS is the key technology for every vehicle tracking system. The GPS is employed to provide users the coordinates of current location of vehicle.
- *DC Motor*
DC motor is one in the class of rotary machine that convert direct current electrical energy into mechanical energy. We use 12v DC motor with 200rpm for locking the person in the driving seat. The motor is attached with the ring gear which is in contact with circular pinion. It is rotated for ward to lock and reverse to unlock.
- *Vibration Sensor*
This sensor module produce logic states depends on vibration and external force applied on it. If there is no vibration this module gives logic LOW output. When it feels vibration then output of this module goes to logic HIGH. We use this sensor in order to ensure that the vehicle is in motion.
- *Relay*
A relay is a electrically operated switch [4]. This is used to stop the vehicle. Actually we require a 12V, 40A relay but it is rarely available so we use 4 relays of 12V,10A those are connected in parallel to get required values. The NC pin and the middle pin connected with the car fuse connect key and the ignition system.
- *Trapping system*
A system for locking the driver in the seat and don't let him to escape. A portion of internal ring gear is the main part. It has locking technique to stop to and fro motion as shown in fig.2 .
- *Locking system*
The locking system in this work contains one rack and pinion together with a DC motor. Which is fitted inside the door. A hole is made on the door frame, So the rack can completely lock the door and can open according to user preference. Rack and pinion of any hard substance can be used.

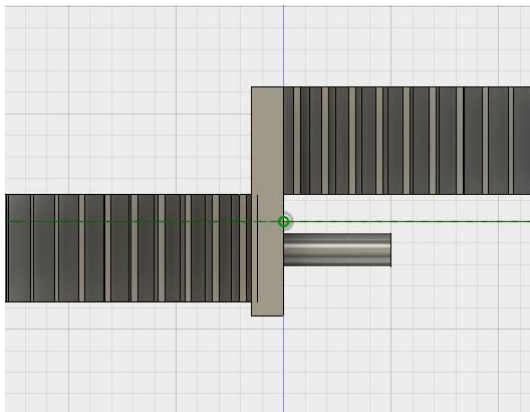

Fig. 2 Arrangement in Trapping system to prevent to and fro motion

- *Motor Driver*

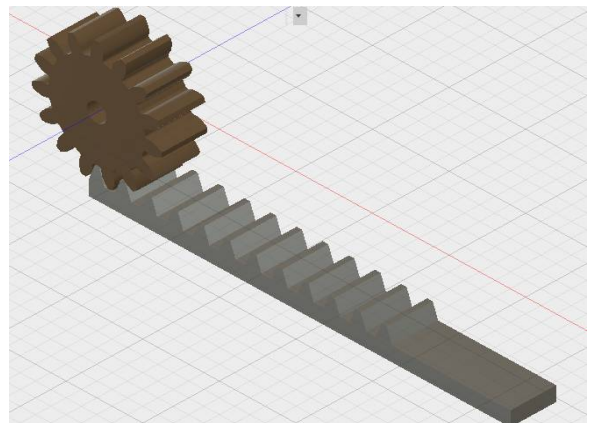

Fig.3 Rack and pinion arrangement in Locking system.

International Journal of Innovative Research in Computer and Communication Engineering

(An ISO 3297: 2007 Certified Organization)

Website: www.ijircce.com

Vol. 5, Issue 10, October 2017

The micro-controller usually operates in low current and voltage which is not sufficient for powerful motors. In order to solve this problem it is necessary to use a motor driver.L298N motor driver is used in this work, which is capable of providing a maximum supply voltage of 46V and Maximum output DC current of 4A [14]. It can also control the direction of motor.

V. SOFTWARE SPECIFICATION

- *Arduino IDE Software*
A software used for compiling the program. It can be used to write the program into the micro-controller. This software uses C programming language for coding. We use this software in order to write the program, which direct micro-controller to control and coordinate every peripheral used in the system.
- *Fusion 360*
This is a designing software by auto-desk , which allow us to simulate the system as well. It is used to design the locking and trapping system,also to simulate.
- *Android Studio*
Android studio is an integrated development environment (IDE) for android operating system, specially designed for application development. The programs are written in JAVA. Here it is for developing a simple user interface, which can send, read messages in background and perform other functionalities in less complicated way.

VI.FLOWCHARTS

The proposed System contains a hardware part and a software part. The flowchart of hardware part is shown in Fig.4. The software part is just a mobile application which will send message when button pressed according to the button name also it read the message and read the co-ordinate and locates in Google maps as in Fig.5.

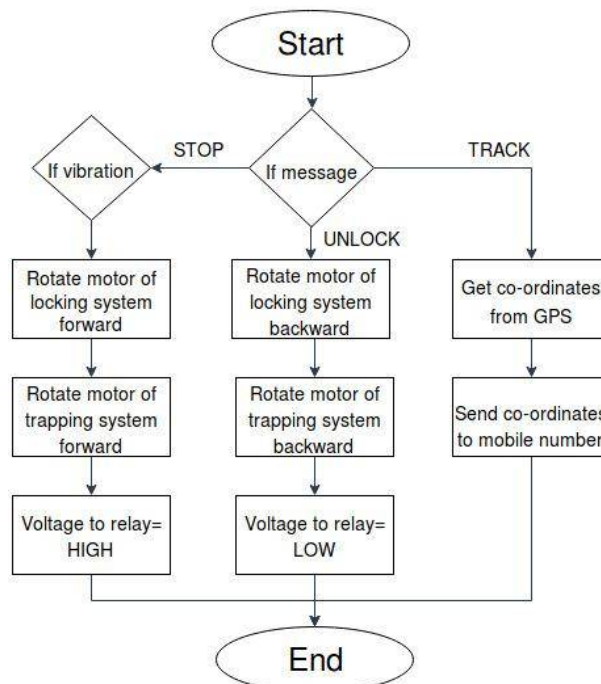

Fig.4 Illustrate the flow chart of hardware in the proposed system. It waits for a message and when a message received it will check the content. If it is STOP the system will check for the vibration sensor value. This is to ensure that the vehicle is in motion then only the driver will be in seat. If no vibration it will wait until vibration occurs. Then it will rotate the motor of the locking and trapping system. If the message received is TRACK it receives the co-ordinates and send to the mobile number. It will rotate the motor backward if the message is UNLOCK the trap and lock can open through mobile only.

International Journal of Innovative Research in Computer and Communication Engineering

(An ISO 3297: 2007 Certified Organization)

Website: www.ijircce.com

Vol. 5, Issue 10, October 2017

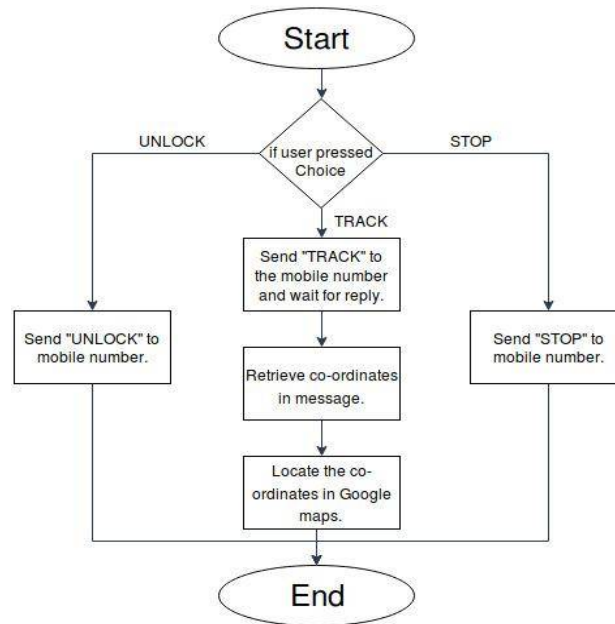

Fig.5 Illustrate the flow chart of software in the proposed system. It provides 3 choices to user. If the selection is STOP or UNLOCK it will send a message to registered number with the option name as content. It will send a TRACK message for the corresponding option and wait for the reply from hardware. If the message is received, It will retrieve the latitude and longitude from the message and locate in Google map thereafter

VII. RESULT AND DISCUSSION

1) Test of Vehicle Tracking functionality, of the Proposed System.

When owner triggers the operation by single button click on the mobile application, this functionality gets initiated and SMS sends to GSM modem inside the vehicle. The GPS receiver receives geographic coordinates (longitude & latitude) from the satellites. Then the data is read by Arduino based microcontroller and information about location of vehicle is then transmitted through GSM network to owners mobile phone. A test was done to detect the location of the tracking system. The system worked well and location was sent to owner/user through SMS successfully. The mobile application successfully retrieved the latitude, longitude positions and located in Google maps.

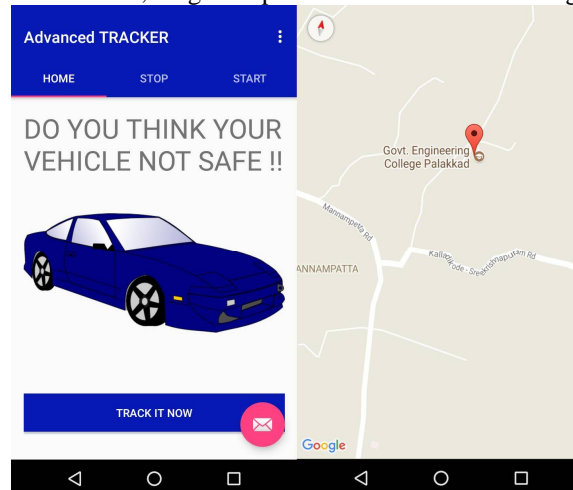

Fig.6 Illustrate the tracking functionality in the mobile application. When pressed the "TRACK IT NOW" button in the home screen loads the map activity. The marker is added according to the Latitude and longitude received. The figure on the right side shows the current location of the system while testing.

International Journal of Innovative Research in Computer and Communication Engineering

(An ISO 3297: 2007 Certified Organization)

Website: www.ijircce.com

Vol. 5, Issue 10, October 2017

2) Test of Vehicle stopping functionality, of the Proposed System.

In-order to stop the vehicle we use a relay module, a test was done to test this functionality. We connected a LED to the relay, and the stop button in the android application pressed. The LED turned off and the functionality tested successfully.

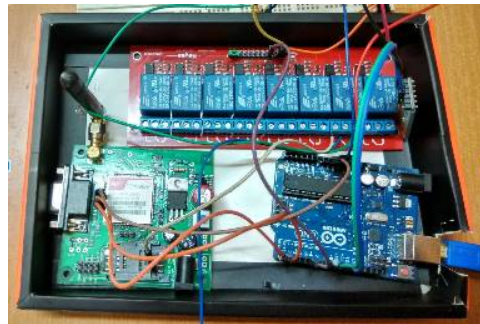

Fig.7 Illustrate a part of our proposed system, it contains an Arduino, relay and GSM shield.

3) Simulation of locking system

A pinion of 15 teeth have been generated with add-ons in fusion 360 and pinion teeth have been generated as in [15]. Then the simulation have been created. As a result, when the pinion rotates clockwise direction the rack move forward and the movement is in reverse direction if the rack rotated anticlockwise.

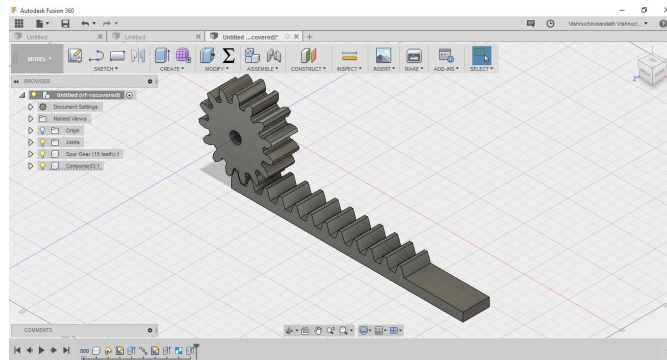

Fig.8 Illustrate the rack and pinion arrangement of the locking system during simulation.

4) Simulation of trapping system

A spur teeth of 150 teeth with the Fusion 360 add-ons, and a cylinder of same height were created. With these two components an internal ring gear war created. Then we split it into two parts and a little displacement added in-order to make the rotation complete in reverse direction. A lock arrangement also added so that it restrict movement when it locked. The motion of the two piece is tested with simulation. Just need to add a DC motor with corresponding spur teeth to complete the system.

International Journal of Innovative Research in Computer and Communication Engineering

(An ISO 3297: 2007 Certified Organization)

Website: www.ijirccce.com

Vol. 5, Issue 10, October 2017

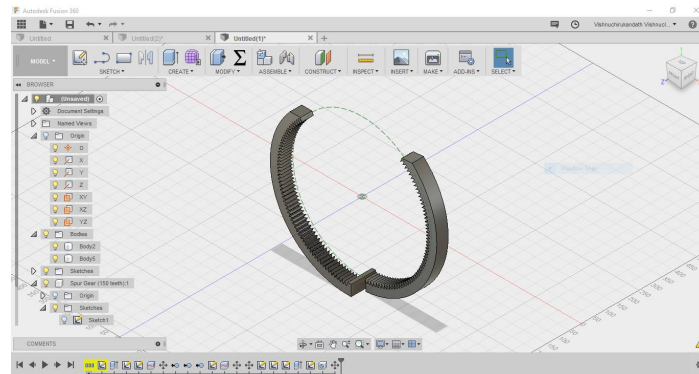

Fig.9 Illustrate the special arrangement of the locking system during simulation.

VIII. ADVANTAGES AND APPLICATIONS

- Applications of the System

The main application of the system is to recover the stolen vehicle. The additional subsystem helps to catch the thief, so that the rate can be controlled easily. The system can also used to lock the children in side vehicle when the parent gone out, so many such incidents have been reported recently. If we pressed “STOP” button in mobile application the chance for kids to start car can be eliminated.

- Advantages of the System

This system make use of Arduino and GSM module so the complexity can be reduced easily. The system is cost effective, that is there are so many functionalities. The rate of robberies can be controlled. Ensure safety for children in car.

IX. CONCLUSION AND FUTURE SCOPE

The proposed vehicle tracking system using GPS and GSM technology was developed and tested successfully to track the exact location of a vehicle in real time where action is triggered upon owners interest remotely through mobile application. The vehicle stopping functionality will stop the vehicle so vehicle can be easily recovered ,but this will not stop the rate of vehicle theft. The trapping and locking system provides better way to catch the intruder by punishing him morally we can control the rate of robberies.

This system has a lot of future scopes, we can use IP camera to capture the images of thief and to give notification when someone else started the car. We can add a buzzer to the system so local people can inform police. The trapping system can me modified into a automatic seat belt. Since the existing car door locking system is not efficient, we can use the locking system in this work to provide better safety.

REFERENCES

- 1) News,”A vehicle is stolen every 13 minutes in Delhi; rate up 44% since last yr”,The Times of India, Delhi,2016. [Online] Available : <http://timesofindia.indiatimes.com/city/delhi/A-vehicle-is-stolen-every-13-mins-in-Delhi-rate-up-44-since-last-yr/articleshow/51836205.cms> Accessed on: 15 september 2017.
- 2) Ambade Shruti Dinkar and S.A Shaikh, “Design and Implementation Of Vehicle Tracking System Using GPS”, *Journal of Information Engineering and Applications*, Vol 1, No 3, 2011.
- 3) Sathe Pooja, “Vehicle Tracking System Using GPS”, *International Journal of Science and Research*, Vol 2, No 9, 2013.
- 4) R.Ramani, S.Valarmathy, Dr. N.Suthanthira Vanitha, S.Selvaraju, M.Thirupathi, “Vehicle Tracking and Locking System Based on GSM and GPS”, *I.J. Intelligent Systems and Applications*, Published online August 2013
- 5) SeokJu Lee, Girma Tewolde, Jaerock Kwon, “Design and Implementation of Vehicle Tracking System Using GPS/GSM/GPRS Technology and Smartphone Application”, *IEEE World Forum on Internet of Things*, 2014.
- 6) Selvamurugan T, “Design and Implementation of Vehicle Tracking and Monitoring System using GPS and ARM Processor”, *International Journal of Innovative Research in Advanced Engineering*, Vol 1, No 10, 2014.



ISSN(Online): 2320-9801
ISSN (Print): 2320-9798

International Journal of Innovative Research in Computer and Communication Engineering

(An ISO 3297: 2007 Certified Organization)

Website: www.ijircce.com

Vol. 5, Issue 10, October 2017

- 7) Mohammed K Haizer , K. S Antha, "Design and Implementation of Vehicle Tracking System using GPS/GSM/GPRS Technology and Smartphone Application" , *International Journal of Scientific Engineering and Technology Research*, Vol 4, No 35, 2015
- 8) P.Ramesh, L.Chandra Shekar, "Design and Implementation of Vehicle Tracking System Using GPS/GSM/GPRS Technology and Smart Phone Application", *International Journal & Magazine of Engineering, Technology, Management and Research* , Vol 2, No 3, 2015
- 9) M. Venkatesh, Dr.ShaikMeeravali, "Design and Implementation of Vehicle Tracking System Using GPS, GSM and GPRS Mobile Communication Technology", *International Journal of Professional Engineering Studies*, Vol 7. No 1, 2016
- 10) Md. Marufi Rahman, Jannatul Robaiat Mou , Kusum Tara , Md. Ismail Sarkar, "Real Time Google Map and Arduino Based Vehicle Tracking System", 2nd International Conference on Electrical, Computer & Telecommunication Engineering, 8-10 December 2016.
- 11) <http://www.electronicshub.org/arduino-servo-motor/>
- 12) M.Sailaja,M. Raja Roy,S. Phani Kumar , "Design of Rack and Pinion Mechanismfor Power Generation at Speed Breakers",*International Journal of Engineering Trends and Technology*, Volume 22 Number 8-April 2015
- 13) <http://micro-controllerslab.com/l298n-motor-driver-circuit/>