



International Journal of Innovative Research in Computer and Communication Engineering

(An ISO 3297: 2007 Certified Organization)

Website: www.ijirce.com

Vol. 5, Issue 3, March 2017

A Survey on RF-ID based Automatic Pesticide Dosing

Himanshu Chaudhari¹, Sagar Patel¹, Piyush Patel¹, Dhananjay Shinde¹, Vinita V. Yerande²

Student, Dept. of Instrumentation and Control Engineering, D. Y. Patil College of Engineering, Akurdi, Savitribai
Phule University, Pune, India¹

Assistant Professor, Dept. of Instrumentation and Control Engineering, D. Y. Patil College of Engineering, Akurdi,
Savitribai Phule University, Pune, India²

ABSTRACT: This paper focuses on the automatic pesticide dosing using microcontroller 8051. In India, 70% of the population is engaged in farming; hence most of the earning is from farming. Farmers used various types of pesticides for proper growth of the crop in large scale. And 75-80% of farmers preferred manual method for mixing and spraying those toxic chemicals which are hazardous for health. This project provides the solution to this mixing problem; and we have achieved it by design and construction of an automatic pesticide mixing system. The function of the project is that it senses the moisture level in the soil. If the moisture level in the soil is below the threshold then it will turn on the motor for water. The other part of the paper is the mixing of pesticides and solvents in a container. The proportions of the pesticide and solvents to be mixed is decided using a RF-ID tag, i.e. different proportions of solvents and pesticides will get mixed in the mixing container for different RF-ID tags. This helps avoiding the job of mixing toxic pesticides manually for the farmer and avoids health hazards. And also the accurate proportions of the mixture help in increasing the efficiency of the pesticides to be dosed.

KEYWORDS: Microcontroller 8051,RFID reader, Soil Moisture sensor, Motor, LCD

I. INTRODUCTION

Poorly stored pesticides and improper mixing/loading practices can present a potential risk to our health and to the integrity of the environment. The quality of surface water, groundwater and soil can be degraded in areas where pesticides are stored under inappropriate conditions, improperly mixed and loaded into application tanks and where equipment is washed and rinsed after application. Accidents involving spills or leakages may have serious health and environmental consequences. Over the past several years, Questions concerning proper mixing and loading procedures have also been common. The purpose of this project is, very simply, to provide an automatic and easy to use system for the mixing and loading of pesticides. Often, there is a requirement of fungicides and pesticides for optimal growing of plant and full life of plant. Automating tasks within the farm will enable the avoidance of hazardous human exposure to pesticide and can increase in overall efficiency and productivity of farm. For the achievement of the desired conditions, the use of fungicides, pesticides often done by farmers. Also temperature of greenhouse is high, and the level of CO₂ and humidity is high. Prolonged exposure to these conditions of greenhouse workers leads a hazardous and uncomfortable working environment often there are substantial risks. This project aims at providing a solution to this problem, by doing semi-automation in handling pesticides mixing operation.

II. LITERATURE SURVEY

The moisture levels of the soil used for farming need to be constant at a certain level. Here a moisture level sensor can be used. [1]The detected signal from the soil moisture sensor is processed by a conditional comparator circuit corresponding to different levels of actual soil moisture content. A logic circuit follows the conditional circuit with its



International Journal of Innovative Research in Computer and Communication Engineering

(An ISO 3297: 2007 Certified Organization)

Website: www.ijirce.com

Vol. 5, Issue 3, March 2017

output signals used to activate a system of relays that control the power circuit of the motors used for water pumping. The speed of the motor is varied according to the level of the soil moisture content; the motor is OFF during maximum wet and is running with HIGH speed during dry soil conditions respectively. The duration of water pumping is controlled by a timer circuit where the timer can be designed according to the desired watering time. The preservation of water and need based irrigation are essential for effective operations and management of water in agriculture. A precise estimate of water requirement can be made at each stage of growth of a crop only through electronic sensors. An irrigation control system uses moisture sensor as a feedback element that takes soil moisture as an input, enabling the system to manage the necessary water flow.

Here [2] a constructive attempt has been made to introduce the concept of sensors, methodology of their working and different types of sensors that are used for water management. A clear description of sensors, the inherent technology and the evaluation of parameters are presented. In doing so, the desirable characteristics of sensors and their significance have been clearly brought out. This critical review enables a judicious design and usage of sensors in agriculture. An algorithm was developed [3] with threshold values of temperature and soil moisture that was programmed into a microcontroller-based gateway to control water quantity. The system was powered by photovoltaic panels and had a duplex communication link based on a cellular-Internet interface that allowed for data inspection and irrigation scheduling to be programmed through a web page. The automated system was tested in a sage crop field for 136 days and water savings of up to 90% compared with traditional irrigation practices of the agricultural zone were achieved. Three replicas of the automated system have been used successfully in other places for 18 months. Because of its energy autonomy and low cost, the system has the potential to be useful in water limited geographically isolated areas.

An irrigation machine was converted to be electronically controlled by a programming logic controller [4] that updates geo-referenced location of sprinklers from a differential Global Positioning System (GPS) and wirelessly communicates with a computer at the base station. Communication signals from the sensor network and irrigation controller to the base station were successfully interfaced using low-cost Bluetooth wireless radio communication. Graphic user interface-based software developed in this paper offered stable remote access to field conditions and real-time control and monitoring of the variable-rate irrigation controller. Here the author proposes a cost-effective automatic stand-alone liquid mixer with chaotic PWM controls. [5] The system design utilizes a new diode-based Rossler chaotic system as a random source for chaotically random Pulse Width Modulation (PWM) for controlling speed of DC motor. The simple propeller can be used for chaotically radial advection. Experimental results with image processing inspection show that the chaotic PWM motor control provides a fast and efficient liquid mixing rather than that of periodic mixing processes. The proposed liquid mixer offers a potential alternative to liquid mixing in industrial automation systems.

International Journal of Innovative Research in Computer and Communication Engineering

(An ISO 3297: 2007 Certified Organization)

Website: www.ijircce.com

Vol. 5, Issue 3, March 2017

III. METHODOLOGY

Block Diagram

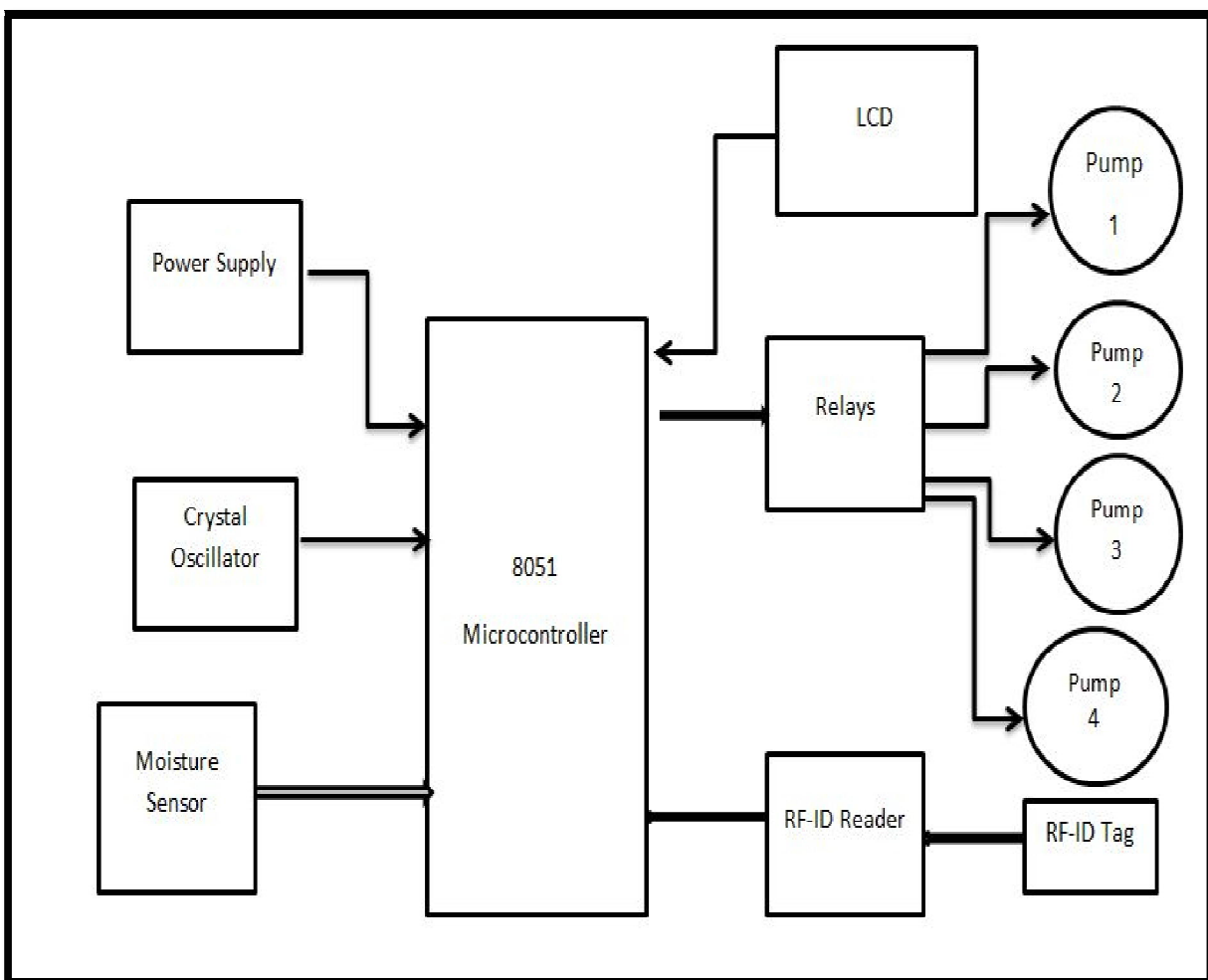

Fig.1: Block diagram

In our paper we propose to implement our Automatic Pesticide Mixing and Irrigation System. It mainly consists of three parts.

- First part is the moisture sensor. This sensor can be used to test the moisture of soil, when the soil is having water shortage, the module output is at high level else the output is at low level. This sensor is placed in the soil for which the moisture has to be sensed. When the output of this sensor is high i.e. the soil is not moist enough then the sensor sends a signal to the controller and the controller performs the action of turning on the water motor.
- Second part is the reading of the RF-ID tag for mixing. This RF-ID tag is read using an RF-ID reader. This RF-ID reader is interfaced with the 8051 microcontroller using serial communication through the Rxd pin of the

International Journal of Innovative Research in Computer and Communication Engineering

(An ISO 3297: 2007 Certified Organization)

Website: www.ijircce.com

Vol. 5, Issue 3, March 2017

controller. Here we have used an RF-ID tag for specifying the proportions of the pesticide and solvent that have to be mixed in the mixing pot. Hence for each different RF-ID tag different ratios of the pesticides and solvents will get mixed.

- The third part is rotating the motors. There are three motors that have been used here. Each for water, pesticide and solvent. These three motors are connected to the 8051 microcontroller using the L293d motor driving IC.. For different proportions of each liquid each motor will be rotated for different time periods. These time periods are decided by which RF-ID tag is read by the RF-ID reader at a particular time. These three motors are connected to the 8051 microcontroller using the L293d motor driving IC.

III.FLOWCHART

- Mixing of Pesticides:

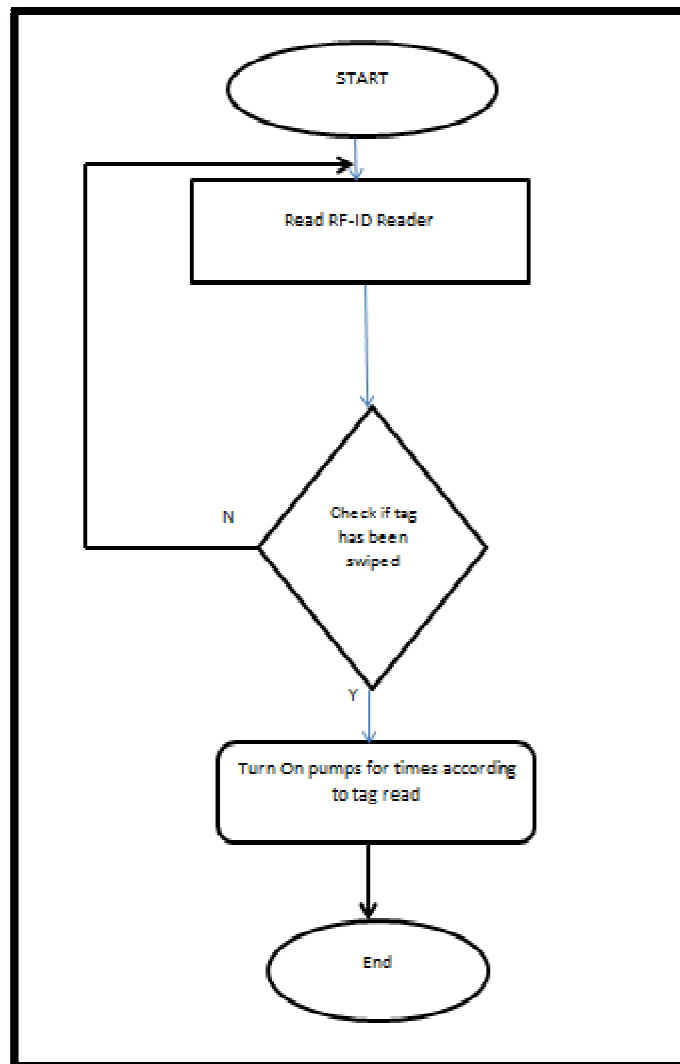

Fig.2: Flow Chart for Mixing of pesticides

International Journal of Innovative Research in Computer and Communication Engineering

(An ISO 3297: 2007 Certified Organization)

Website: www.ijircce.com

Vol. 5, Issue 3, March 2017

STEPS:

1. Turn On RF-ID Reader
2. Check if RF-ID tag is read
3. If No go back to step 1
4. If Yes turn on motor for time periods according to RF-ID tag read

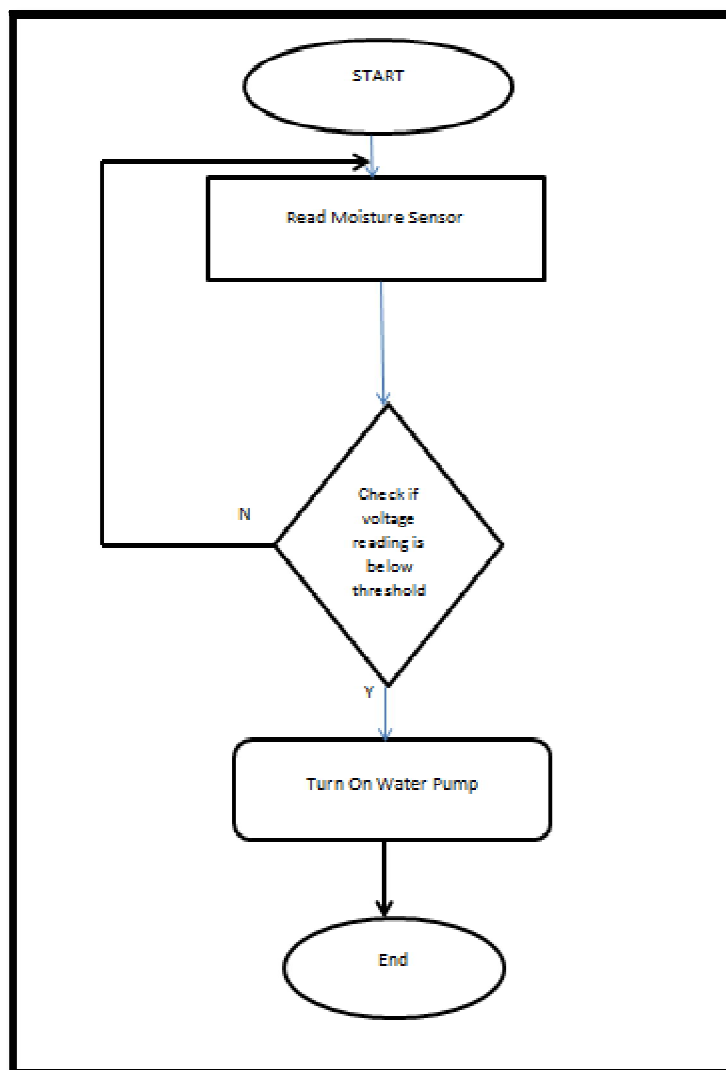

Fig.3: Moisture Sensing and Water Motor Control

STEPS:

1. Read Moisture sensor
2. Check if moisture level is below threshold value
3. If No go back to step 1.
4. If yes turn the water motor or Pump



International Journal of Innovative Research in Computer and Communication Engineering

(An ISO 3297: 2007 Certified Organization)

Website: www.ijircce.com

Vol. 5, Issue 3, March 2017

Advantages:

1. Helps protect farmers from toxic material in the pesticides.
2. Mixtures can be made with highly accurate proportions.
3. Timely watering of the soil and crops avoids them being dried and dead.
4. As water is turned off after proper moisture level is achieved no excess watering is done and wastage of water is avoided.

IV.CONCLUSION

The project was aimed at not just to extend the application of advanced technology in the field of agriculture, but also to bring the technology close to the reach of farmers in financial aspect, in a very convenient way. The project implements smart machinery for agriculture which promises to overcome certain challenges which lie in the present day agriculture. It encourages the use of technology to improve the productivity in agriculture. It reduces certain tedious and hazardous works in agriculture and hence encourages many people to use automatic systems to avoid toxic materials. In this regard, the paper proposes automatic mixing process of pesticides and solvents. The system is easy to operate and is user friendly. It also helps the farmers avoiding hazardous chemicals along with secured farming. The mixing system for pesticides proposed in this project is a collaboration of all basic feasible technologies, to bring out a new and reliable alternative for farmers in tasks involving risks. This project also proposes a system to constantly monitor the moisture levels of the soil and automatic watering in case of low moisture levels. Projects like this encourage farmers to take up automatic systems and avoid unnecessary health risks.

REFERENCES

- [1]"Automatic Control of Agricultural Pumps Based on Soil Moisture Sensing", Beza Negash Getu, Hussain A. Attia Department of Electrical, Electronics and Communications Engineering American University of Ras Al Khaimah Ras Al Khaimah, UAE.
- [2]"Sensors For Managing Water Resources In Agriculture", V. S. Kuncham, N.V. Rao, *IOSR Journal of Electronics and Communication Engineering (IOSR-JECE) e-ISSN: 2278-2834, p- ISSN: 2278-8735. Volume 9, Issue 2, Ver. V (Mar - Apr. 2014), PP 145-163*
- [3] "Automated Irrigation System Using a Wireless Sensor Network and GPRS Module", Joaquin Gutierrez, Juan Francisco Villa-Medina, Alejandra Nieto-Garibay, Miguel Angel Porta-Gandara.,
- [4]"Remote Sensing and Control of an Irrigation System Using a Distributed Wireless Sensor", Network Yunseop (James) Kim, *Member, IEEE*, Robert G. Evans, and William M. Iversen. *IEEE TRANSACTIONS ON INSTRUMENTATION AND MEASUREMENT*, VOL. 57, NO. 7, JULY 2008
- [5]"Automatic stand-alone liquid mixer with chaotic PWM control using diode-based Rössler system", Somchart Hoglad and Wirnol San-Urn. *Proceedings of the International Electrical Engineering Congress 2014*