



Design and Modeling of I2C Bus Controller Using VHDL

Pankaj Kumar Mehto*, Ashish Radhuvansi , Sonu Lal

M.Tech, Dept. of EC, IES College of Technology, Bhopal, India

M.Tech, Dept. of EC, IES College of Technology, Bhopal, India

Assistant Professor, Dept. of EC, IES College of Technology, Bhopal, India

Corresponding author

ABSTRACT: In this paper we focus on the design of I2C bus controller and the interface between the two integrated devices *i.e.* microcontroller and EEPROM, the microcontroller like as a master controller and, the EEPROM like as slave for serial communication in embedded system. The I2C Interface is operating in 7-bit address mode. We can say one master is able to manage 27 or 128 slaves. The components of the I2C bus controller is consist of only a bidirectional two wire and standard protocol which communicate between two integrated circuit or device. First one is serial data (SDA) line and second is serial clock (SCL) line. The I2C protocol was given by Philips Semiconductors for faster devices to communicate with slower devices and each other without data loss. The complete module of I2C bus controller is designed in VHDL and simulated in ModelSIM. The design is also synthesized in Xilinx XST 14.1.

KEYWORDS: I2C Bus, microcontroller, VHDL, ModelSIM, Xilinx XST 14.1.

I. INTRODUCTION

The I2C Master Controller is designed to interface with up to 127 different I2C slave devices. In order to achieve this task, the I2C Master Controller requires several components to make a complete I2C bus interface system. The first components required are a microprocessor and second chip select unit and others I2C slave devices. The microprocessor initiates and configures to all I2C bus transactions. After that, the chip select unit assures that the microprocessor's bus cycles comply to the I2C Master Controller requirements. So, the I2C slave device can be any I2C slave device operating within the specification created by Philips Semiconductor. This thesis is aimed at designing of a Master controller for I2C bus using the **VHDL**. I2C is a two-wire, bi-directional serial bus that provides a simple and efficient method of data exchange between devices. It is most useful for applications requiring occasional communication over a short distance between many devices. The I2C standard is a real multi-master bus including collision detection and arbitration that prevents data corruption if two or more masters attempt to control the bus at the same time. This core, however, supports only single master operations, in which the core is the master. The I2C interface uses a serial data line (SDA) and a serial clock line (SCL) for data transfers.

II. I2C BUS CONTROLLER DESIGN

I2C Protocol generally, a standard communication protocol consists of four parts:

- 1) START signal generation
- 2) STOP signal generation
- 3) Slave address transfer
- 4) Data transfer

International Journal of Innovative Research in Computer and Communication Engineering

(An ISO 3297: 2007 Certified Organization)

Vol. 3, Issue 2, February 2015

III. INTERFACING SERIAL EEPROM (AT24C16) WITH 8051 MICROCONTROLLER (AT89C51) USING I2C BUS

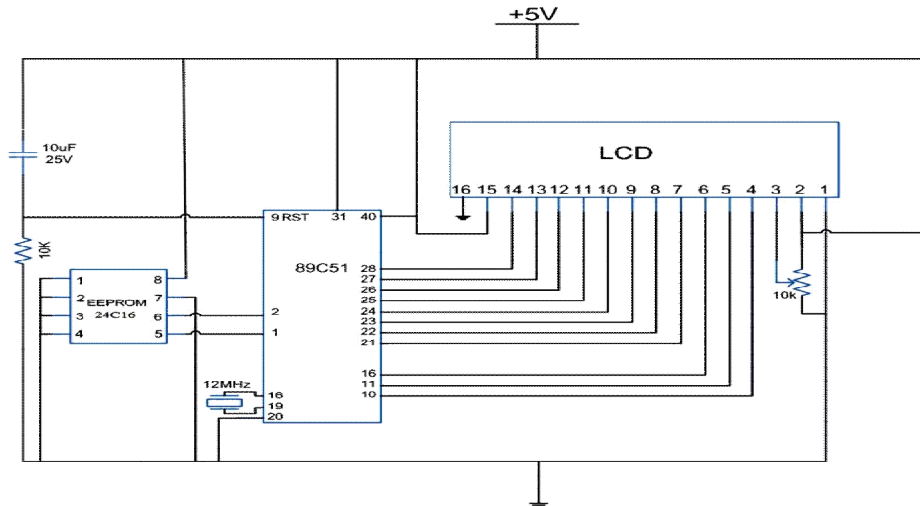

Figure 1 Architecture of AT89C51 microcontroller and AT24C16 EEPROM Interfacing

IV. I2C BUS ARCHITECTURE



Figure1.2 I2C master controller pin level architecture

V. MICROPROCESSOR INTERFACE DESIGN REQUIREMENTS

The subsequent list contains requirements that the microprocessor must follow to make sure proper operation of the



International Journal of Innovative Research in Computer and Communication Engineering

(An ISO 3297: 2007 Certified Organization)

Vol. 3, Issue 2, February 2015

system:

- Chip decides on must be synchronized to the microprocessor clock frequency.
- Address and data must be applicable the entire time chip select is asserted during a write cycle.
- Data is latched into the appropriate I2C Master Controller registers on the rising edge of the third microprocessor clock.
- Data strobe acknowledges is controlled externally to the I2C Master Controller. It is up to the designer to insert the appropriate wait states to achieve the requirements above.

VI. TOP-LEVEL SIGNAL DESCRIPTIONS

Table-1 consists of the input/output signals of the I2C bus Master bus controller. The address bus is used to 3-bit input pin for the I2C master bus controller. The data input to the master bus controller is 8-bit and data output from the master bus controller is too 8-bit. Serial data line (SDA) and Serial clock line (SCL) both are in out pins between master controller and slave devices. Chip Select is the input pin to the controller which is synchronizes with the clock from microprocessor. RD and WR both are input pins to the master controller from the microprocessor.

Table1 Signal Description of I2C Master Controller

Signal	Type	Description
madr [7:0]	Input	I2C slave address
mbdr_i2c [7:0]	In-out	I2C data for uP
mbdr_micro	Input	uP data to output on I2C bus
sda	In-out	I2C serial data
Scl	In-out	I2C serial clock
cs	Input	master/slave select
srw	In-out	slave read/write from microprocessor
txak	Input	I2C write signal from microprocessor
Sys_clock	Input	I2C Input clock from microprocessor
reset	Input	Reset
msta_rst	Out	resets MSTA bit if arbitration is lost
rsta	Input	repeated start
rsta_rst	Out	repeated start reset
mbb	Out	bus busy
mcf	In-out	data transfer
maas	In-out	addressed as slave
mal	In-out	arbitration lost
mif	Out	interrupt pending
mbr_cr_wr	Input	indicates that MCBR register was written
mif_bit_reset	Input	indicates that the MIF bit should be reset
mal_bit_reset	Input	indicates that the MAL bit should be reset

VII. DESIGN STEPS

The practical explanation of I2C master has to be explained in the VHDL. That is called intend module / core. The test bench program has to be urbanized to test the intend module. The test bench provides the input to the intend module and verifies the outputs. The test bench has to be written in such way to ensure the intend module in all feasible conditions. VHDL simulator device is utilized to modelsim which confirm the intend functioning.

International Journal of Innovative Research in Computer and Communication Engineering

(An ISO 3297: 2007 Certified Organization)

Vol. 3, Issue 2, February 2015

VIII. FLOWCHART

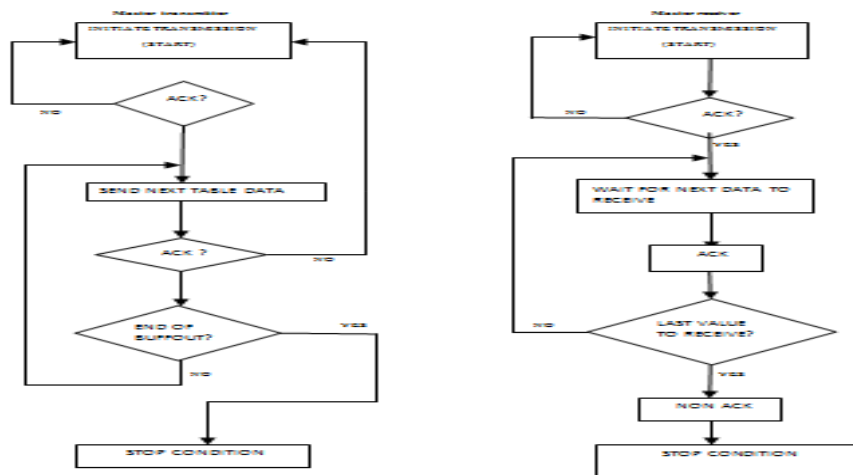

Figure 1.3 Communication application flowchart

IX. SIMULATION RESULT

The VHDL code for I2C master controller is compiled in the ModelSim PE Student Edition 10.4 software tool. The test bench of this module is simulated and followings are the results.

Here in all the cases I have taken clock frequency of 20MHZ that is time period of 50ns and duty cycle of 50%.

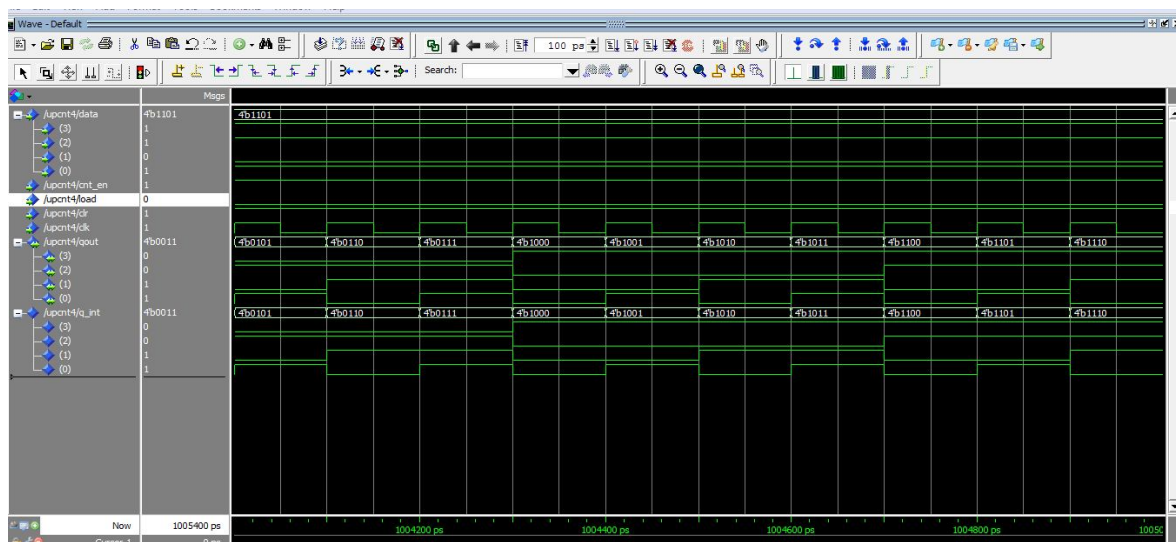

Figure 1.4 Clock count of I2C master controller.

International Journal of Innovative Research in Computer and Communication Engineering

(An ISO 3297: 2007 Certified Organization)

Vol. 3, Issue 2, February 2015

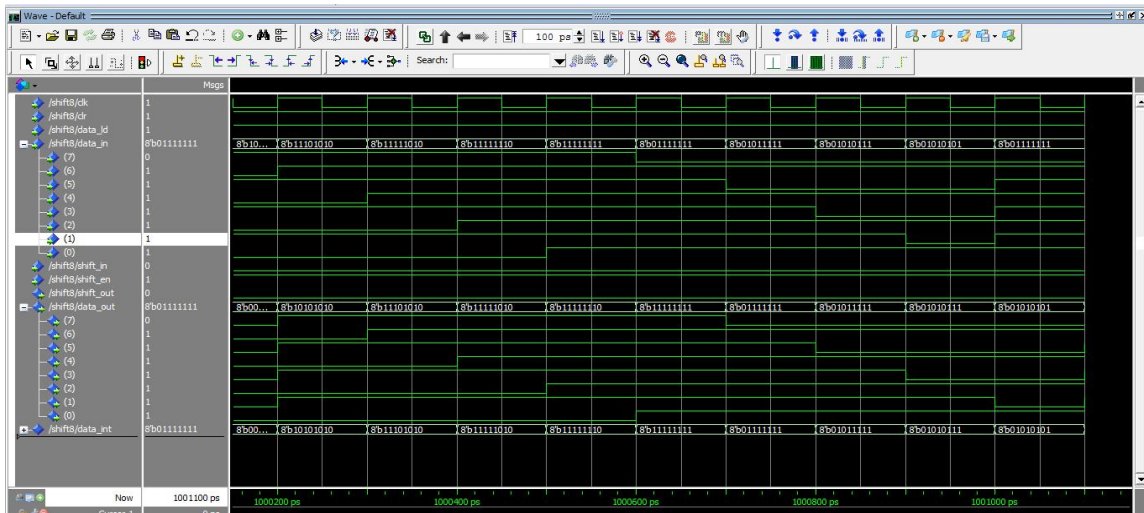

Figure1.5 Data register of I2C master controller.

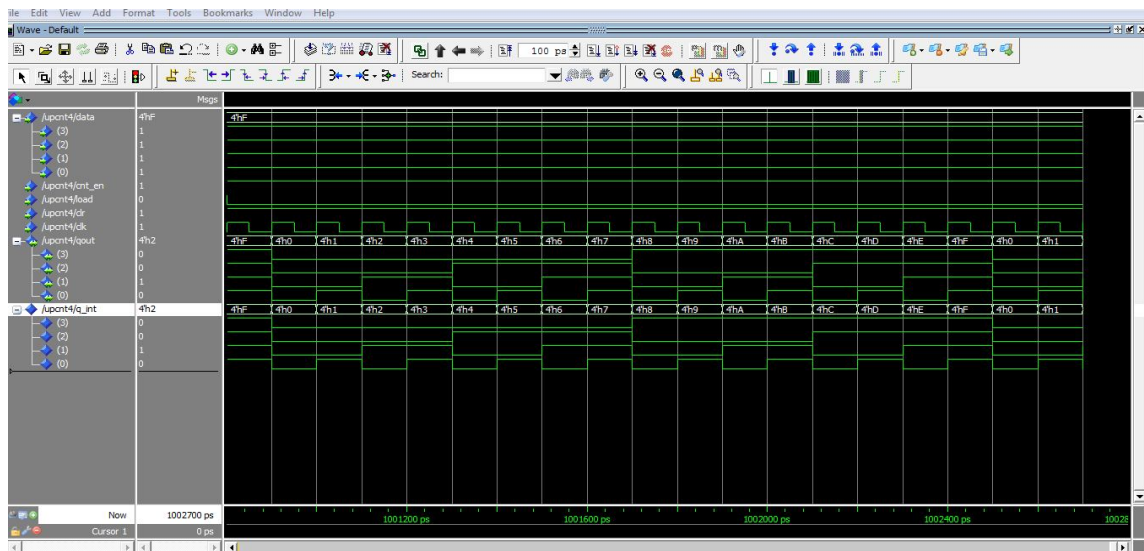

Figure1.6 Bit count of I2C master controller.

International Journal of Innovative Research in Computer and Communication Engineering

(An ISO 3297: 2007 Certified Organization)

Vol. 3, Issue 2, February 2015

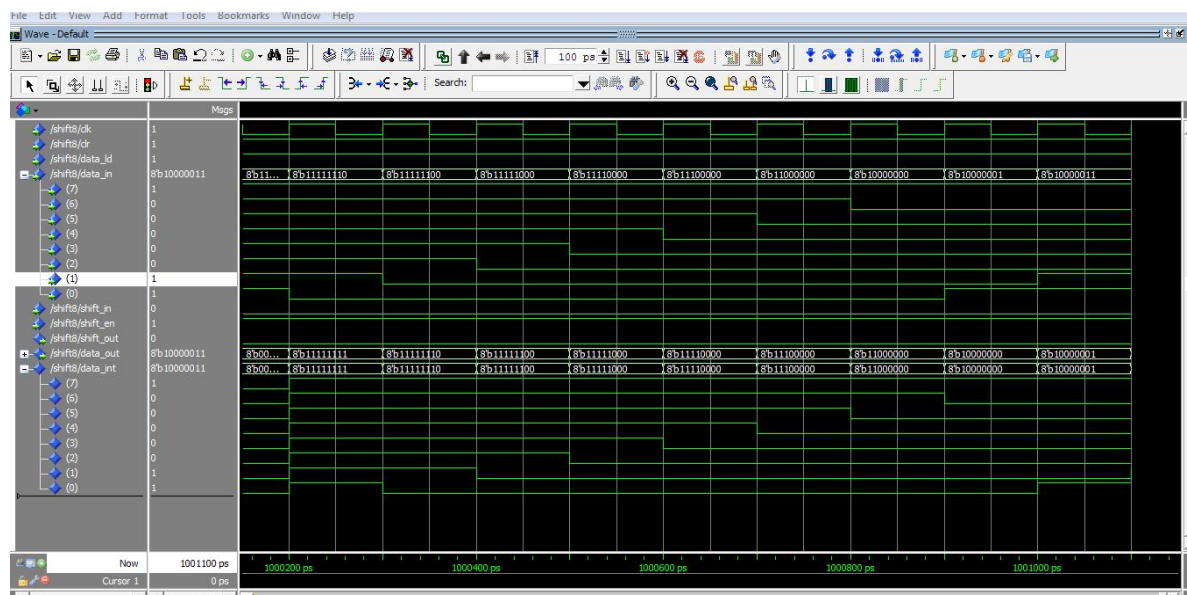

Figure 1.7 Header data register of I2C master controller.

X. CONCLUSION

The results of simulation and desired behaviour of the I2C bus controller agree. The interfacing of microcontroller (master) and serial EEPROM (slave) has done by using I2C bus which elaborates that I2C components are working as our desired conditions. The design of I2C controller using VHDL, simplifies the design process. The designer can write his design report not including any specific fabrication equipment. If a new technology emerges, designers do not require redesigning the circuit. He plainly input the intend program to the logic synthesis tool and creates a new gate level netlist using the new fabrication equipment. The judgment synthesis tool will optimize the circuit in area and timing for the new technology.

ACKNOWLEDGEMENT

The correspondence author is thankful to all the faculty members of department of Electronics & Communication, IES College of Technology Bhopal, M.P. and India for continuous support and encouragement. This is an opportunity to prove our technical skill for the benefit of social civilization.

REFERENCES

1. D. Paret: Le bus I²C, de la théorie à la pratique, ISBN2100017179, ed. DUNOD, Paris 1993.
2. IEEE Computer Society. IEEE Standard Verilog® Hardware Description Language, IEEE Std 1364-2001, The Institute of Electrical and Electronics Engineers, Inc, 28 September 2001.
3. J. Bhaskar, second Edition, BSP, A Verilog HDL Primer.
4. Muhammed Ali Mazidi, Janice Gillispie Mazidi & Rolin D. Mckinlay, second Edition, Pearson Education. The 8051 Microcontroller and Embedded Systems, using Assembly and C.
5. M. D. Ciletti. Advanced Digital Design with the Verilog HDL, Publishing House of Electronics Industry, 2004.4
6. <http://www.engineersgarage.com/microcontroller/8051projects/interface-serial-eprom-24c02-AT89C51-circuit>
7. http://www.charmedlabs.com/index.php?option=com_smf&Itemid=36&topic=640.0.
8. SAA1064, 4-digit Led-driver with I²C bus interface datasheet, <http://www.semiconductors.philips.com>
9. www.latticesemi.com, I²C Master Controller reference design
10. Embedded Platform Excalibur Altera, <http://www.altera.com>
11. PCF 8584, I²C bus controller datasheet, <http://www.semiconductors.philips.com>
12. The I²C -Bus specifications version 2.1 January 2000 <http://www.semiconductors.philips.com/buses/i2c>
13. R. Herveille. I2C-Master Core Specification, Rev. 0.9, 2003.7