



# International Journal of Innovative Research in Computer and Communication Engineering

(An ISO 3297: 2007 Certified Organization)

Website: [www.ijircce.com](http://www.ijircce.com)

Vol. 5, Issue 5, May 2017

## Solar Powered Lawn Mower for Grass Trimming

Prof. Mrunali P. Makwana, Vynkatesh Pandit, Saurabh Sindphalkar, Vinayak Kamble

Department of E&TC, RMD Sinhgad School of Engineering, Warje Pune, India

**ABSTRACT:** In order to solve the problem of the traditional intelligent mower, which cannot cover the lawn area and operate complexly, a visual, wireless, autonomous mower system via machine vision is designed. Unlike other robotic lawn mowers on the market, this design requires no perimeter wires to maintain the robot within the lawn and also with less human effort in the manual mode operation. Through an array of sensors safety takes major consideration in the device, this robot will not only stay on the lawn, it will avoid and detect objects and humans. And also it detect the land boundaries and start mowing upon the predefine pattern with the help of installed with the help of color sensor and ultrasonic sensor.

**KEYWORDS:** Intelligent lawn mower, machine vision, color sensing, obstacle detection, automation,

### I. INTRODUCTION

In the time where technology is merging with environmental awareness, consumers are looking for ways to contribute to the relief of their own carbon footprints. Pollution is manmade and can be seen in our own daily lives, more specifically in our own homes. And also for electrically powered mowers it consumes large amount of energy for the working. Nowadays everything going under automation so here also I tried to reduce the human effort for the mowing job. Our new design for an old and outdated habit will help both the consumer and the environment. This robotic mowing device is solar powered which gets charged its battery while mows on the lawn from sunlight and also we can charge it manually from main supply. IR sensors are used for obstacle avoidance [1]. This research aim to develop a device that will relieve the consumer from mowing their own lawns and will reduce both environmental and noise pollution. It also helpful to reduce the human effort for the mowing work and designing of the lawn. This design is meant to be an alternate green option to the popular and environmentally hazardous gas powered lawn mower [2]. The microcontroller moves the vehicle motors in forward direction in case no obstacle is detected. On obstacle detection the IR sensor monitors it and the microcontroller thus stops the grass cutter motor to avoid any damage to the object/human/animal whatever it is. Microcontroller then turns the robotic as long as it gets clear of the object and then moves the grass cutter in forward direction again. Ultrasonic sensors "are based on the measurement of the properties of acoustic waves with frequencies above the human audible range," often at roughly 40 kHz. They typically operate by generating a high-frequency pulse of sound, and then receiving and evaluating the properties of the echo pulse. Color light sensors are awesome devices for everything from environmental sensors to general robotics. They can be used to monitor slowly changing events like algae blooms or leaf death, or to determine light absorption through a medium. But for all their utility, they have some flaws. First off, they can be complicated to interface to since RGB data often has to be derived using complex signal processing [3]. Secondly, they're less than rugged, and when you want to deploy one in the field you need a device that can stand up to the weather. Even moisture in the air can make an unprotected sensor unreliable.

However, they has the following problems: the reference can only achieve simple obstacle avoidance, but not analysis external environment dynamically.

### II. DESIGN OF WHOLE SYSTEM

The hardware structure is consisted of mobile, mowing subsystem, Wi-Fi communication subsystem and so on, the structure diagram of system is shown in Fig.1,. By the host computer software written by C,you can use mouse to

# International Journal of Innovative Research in Computer and Communication Engineering

(An ISO 3297: 2007 Certified Organization)

Website: [www.ijircce.com](http://www.ijircce.com)

Vol. 5, Issue 5, May 2017

draw the mowers mowing range or mowing patterns to the mowers which are working at the same time. The host computer software make decisions of action signals for mover by mowing range (or mowing pattern) and scene information, give the decisions to mowing subsystem through Wi-Fi wireless communication subsystem. The lawn mower will not repeat the same path through the decisions which are made by host computer software, and coverage all the mowing range. Similarly IR sensor is used to detect the obstacle in the path of the robotic mower. In the device Lithium polymer battery is used because its gives an higher power for the motor. For the movement of the system dc motor with 30 rpm rating are used. And for the cutting blade it choose BLDC motor with 1200KV rating which gives 500 rpm at 12.V supply. solar panel 10 Watts 16.4 volts is used to convert solar energy that is sun light to electrical energy[4].

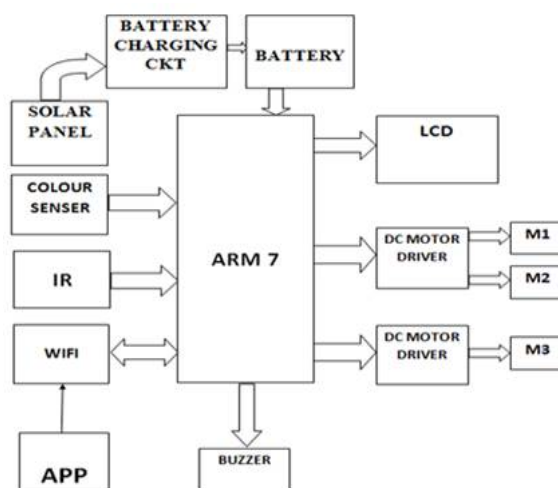

Fig.1 The structure diagram of system

### III. DESIGN OF HARDWARE OF MOWING SUBSYSTEM

Mowing machine system is mainly composed of minimum system of SCM, motor driver module, wireless communication module, power supply module and so on.

#### 3.1 Microcontroller LPC2138

The LPC2131/32/34/36/38 microcontrollers are based on a 16/32-bit ARM7TDMI-S CPU with real-time emulation and embedded trace support, that combine the microcontroller with 32 kB, 64 kB, 128 kB, 256 kB and 512 kB of embedded high-speed flash memory. A 128-bit wide memory interface and a unique accelerator architecture enable 32-bit code execution at maximum clock rate. For critical code size applications, the alternative 16-bit Thumb mode reduces code by more than 30 % with minimal performance penalty. Due to their tiny size and low power consumption, these microcontrollers are ideal for applications where miniaturization is a key requirement, such as access control and point-of-sale. With a wide range of serial communications interfaces and on-chip SRAM options of 8 kB, 16 kB, and 32 kB, they are very well suited for communication gateways and protocol converters, soft modems, voice recognition and low-end imaging, providing both large buffer size and high processing power. Various 32-bit timers, single or dual 10-bit 8-channel ADC(s), 10-bit DAC, PWM channels and 47 GPIO lines with up to nine edge or level sensitive external interrupt pins make these microcontrollers particularly suitable for industrial control and medical systems.

# International Journal of Innovative Research in Computer and Communication Engineering

(An ISO 3297: 2007 Certified Organization)

Website: [www.ijirccce.com](http://www.ijirccce.com)

Vol. 5, Issue 5, May 2017

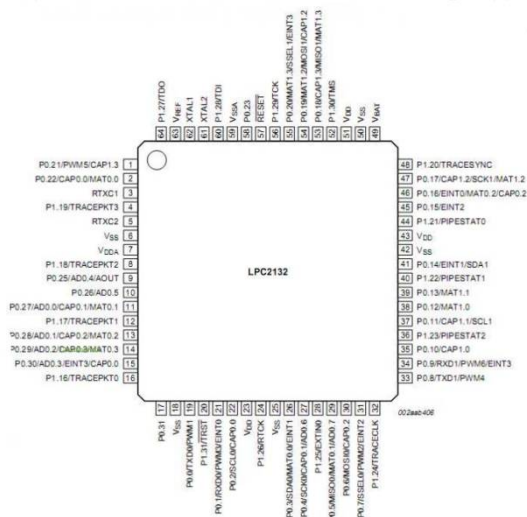

Fig. 2 ARM LPC2138

### 3.2 Motor driver

L293D is a dual H-bridge motor driver integrated circuit (IC). Motor drivers act as current amplifiers since they take a low-current control signal and provide a higher-current signal. This higher current signal is used to drive the motors. L293D contains two inbuilt H-bridge driver circuits. In its common mode of operation, two DC motors can be driven simultaneously, both in forward and reverse direction. The motor operations of two motors can be controlled by input logic at pins 2 & 7 and 10 & 15. Input logic 00 or 11 will stop the corresponding motor. Logic 01 and 10 will rotate it in clockwise and anticlockwise directions, respectively. Enable pins 1 and 9 (corresponding to the two motors) must be high for motors to start operating. When an enable input is high, the associated driver gets enabled. As a result, the outputs become active and work in phase with their inputs. Similarly, when the enable input is low, that driver is disabled, and their outputs are off and in the high-impedance state.

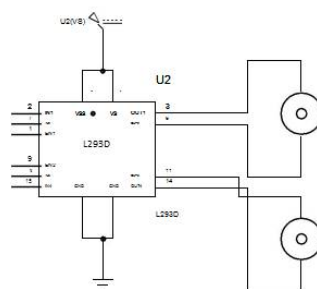

Fig. 3 Motor driver module

### 3.3 WIFI Module

The ESP82XX Wi-Fi Module is a self contained SOC with integrated TCP/IP protocol stack that can give any microcontroller access to your Wi-Fi network. The ESP82XX is capable of either hosting an application or offloading all Wi-Fi networking functions from another application processor. This module comes with AT commands firmware which allows you to get functionality like arduino Wi-Fi shield, however you can load different firmwares to make your own application on the modules' memory and processor. It's a very economic module and has a huge and growing

# International Journal of Innovative Research in Computer and Communication Engineering

(An ISO 3297: 2007 Certified Organization)

Website: [www.ijircce.com](http://www.ijircce.com)

Vol. 5, Issue 5, May 2017

community support. This module has onboard 80Mhz low power 32 bit processor which can be used for custom firmwares. This also means that you can host small webpages without any external controller. For more details see :NODEMCU . The ESP8266 supports APSD for VoIP applications and Bluetooth co-existence interfaces, it contains a self-calibrated RF allowing it to work under all operating conditions, and requires no external RF parts. ESP8266 is transforming the world with its low cost and high features which makes it an ideal module for Internet Of Things (IOT). It can be used in any application where you need to connect a device to your local network or internet.

The ESP8266 is a low-cost Wi-Fi chip with full TCP/IP stack and microcontroller capability produced by Shanghai-based Chinese manufacturer, Expressif Systems.

The chip first came to the attention of western makers in August 2014 with the ESP-01 module, made by a third-party manufacturer, AI-Thinker. This small module allows microcontrollers to connect to a Wi-Fi network and make simple TCP/IP connections using Hayes-style commands. However, at the time there was almost no English-language documentation on the chip and the commands it accepted. The very low price and the fact that there were very few external components on the module which suggests that it could eventually be very inexpensive in volume, attracted many hackers to explore the module, chip, and the software on it, as well as to translate the Chinese documentation.

The ESP8285 is an ESP8266 with 1 MB of built-in flash, allowing for single-chip devices capable of connecting to Wi-Fi.

## IV. FLOWCHART

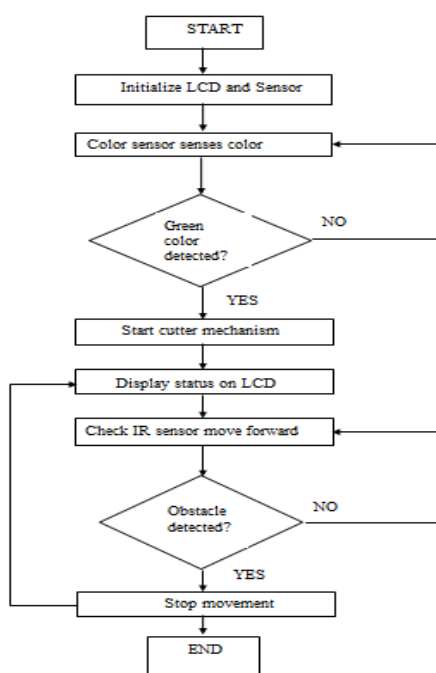

## V. CONCLUSION

The main aim of this project is to make a solar powered automated robotic lawn mower system which will help to mow the lawn in different design with lesser human effort. Advantages of this system are used components are of low cost so and in bulk production and adding of few more sensors doesn't make any difference.



ISSN(Online): 2320-9801  
ISSN (Print): 2320-9798

# International Journal of Innovative Research in Computer and Communication Engineering

*(An ISO 3297: 2007 Certified Organization)*

Website: [www.ijircce.com](http://www.ijircce.com)

Vol. 5, Issue 5, May 2017

## REFERENCES

- [1] MingCong, "Intelligent robot mowers areview", Robot, Vol 29, NO.4,pp. 407-416, July 2007.
- [2] Jie Huang, "Designof robot lawn mower", Embedded technology, Vol 36, NO.8,pp. 33-40, 2010.
- [3] MingxuanFan,"Design and research of full area coverage mobile robot obstacle avoidance strategy and multi sensor", Nanjing, Nanjing University of Science and Technology, 2002.
- [4] Guo-Shing Huang And Keng-ChihLin proposed " Intelligent auto saving energy robotic lawn mower". IEEE transaction on robotics .pg 4130 to 4136, 2010