



International Journal of Innovative Research in Computer and Communication Engineering

(An ISO 3297: 2007 Certified Organization)

Website: www.ijircce.com

Vol. 5, Issue 3, March 2017

IOT BASED Smart Garbage Monitoring and Air Pollution Control System

Kalyani Ghute¹, Gayatri Thakare², Mayuri Wahane³, Akshay Holey⁴, Prof. Mayuri.M.Soni⁵

Students, Department of Electronics and Telecommunication, Prof Ram Meghe Institute of Technology and
Research Badnera, Amravati, Maharashtra, India^{1,2,3,4}

Assistant Professor, Department of Electronics and Telecommunication, Prof Ram Meghe Institute of
Technology and Research Badnera, Amravati, Maharashtra, India⁵

ABSTRACT: This project IOT Garbage Monitoring system is a very innovative system which will help to keep the cities clean. This system monitors the garbage bins and informs about the level of garbage collected in the garbage bins via a web page. For this the system uses ultrasonic sensors placed over the bins to detect the garbage level and compare it with the garbage bins depth. This system also detects the harmful gases in the air with the help of gas sensors. Whereas a web page is built to show the status to the user monitoring it. The web page gives a percentage of harmful gases and shows the level of garbage collected. The LCD screen shows the status of the garbage level and percentage of harmful gases. The system puts on the buzzer when the level of garbage collected crosses the set limit. Thus this system helps to keep the city clean by informing about the garbage levels of the bins by providing graphical image of the bins via a web page.

KEYWORDS: Internet of Things, Ultrasonic Sensors, Gas Sensors, Arduino, Web Portal

I. INTRODUCTION

This project IOT Based Smart Garbage Monitoring system is a very innovative system which will help to keep the cities clean. This system monitors the garbage bins and informs about the level of garbage collected in the garbage bins via a web page. This system uses ultrasonic sensors placed over the bins to detect the garbage level and compare it with the garbage bins depth. This system also detects the harmful gases in the air with the help of gas sensors. The system makes use of AVR family microcontroller, LCD screen, Wifi modem for sending data and a buzzer. The system is powered by a 12V transformer. The LCD screen is used to display the status of the level of garbage collected in the bins. Whereas a web page is built to show the status to the user monitoring it. The LCD screen shows the status of the garbage level. The system puts on the buzzer when the level of garbage collected crosses the set limit. Thus this system helps to keep the city clean by informing about the garbage levels of the bins and carbon gas value in percentage by providing graphical image of the bins via a web page.

II. RELATED WORK

In our project we are using two ultrasonic sensors which sense the level of garbage bin and two gas sensors which detect the harmful gases in the air. These sensors are connected to the AVR family microcontroller which is interfaced with LCD display which shows the status of bins. We also used Wi-Fi module which is used to transmit data for webpage applications. We are using one buzzer which gives beep whenever any dustbin is full. The whole system is powered by 12V transformer.

Here, we are indicating four levels: Low, Medium, High and Full by using Embedded C programming. In the first case when both the dustbins are empty, the webpage and LCD will display Low level. Then according to the different levels of garbage it will show Medium, High or Full level on LCD as well as webpage. When any of the dustbin is full it gives beep and when both the dustbins are full it gives loud beep. Along with this the web page and LCD will display the level of harmful gases in the surrounding. In this way Authority can collect the garbage whenever dustbin is full.

International Journal of Innovative Research in Computer and Communication Engineering

(An ISO 3297: 2007 Certified Organization)

Website: www.ijirccce.com

Vol. 5, Issue 3, March 2017

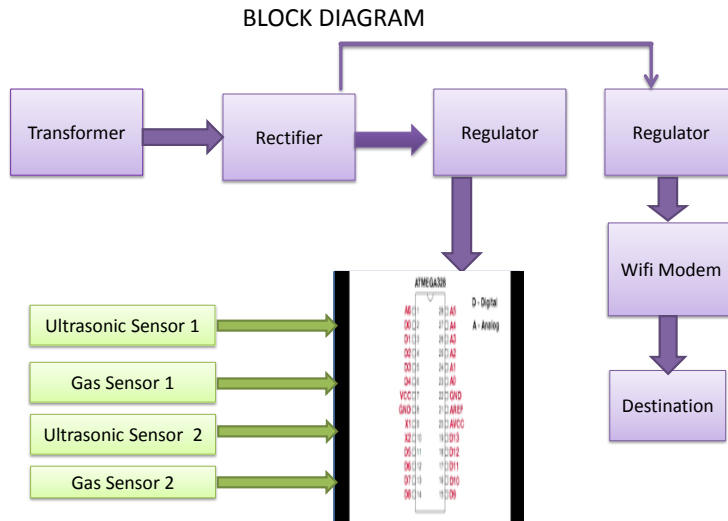

III. PROPOSED ALGORITHM

A. Design Considerations:

- AVR Family Microcontroller
- Ultrasonic Sensors
- Gas Sensors
- Arduino.
- Wifi Module

B. Description of the Proposed Algorithm:

• AVR Family Microcontroller:

The High-performance Atmel picopower 8 bit AVR RISC based microcontroller combines 32KB ISP flash memory with read while write capabilities, 1024B EEPROM, 2KB SRAM, 23 general purpose I/O lines, 32 general purpose working registers, three flexible timers/counters with compares modes, internal and external interrupts, serial programmable USART, a byte oriented 2-wire serial interface, SPI serial port, a 6 channel 10-bit A/D converter, programmable watchdog timer with internal oscillator and five software selectable power saving modes. The device operates between 1.8-5.5 volts. By executing powerful instructions in a single clock cycle, the device achieves throughputs approaching 1MIPS per MHz, balancing power consumption and processing speed.

• Ultrasonic Sensor

An ultrasonic Sensor transmit ultrasonic waves into the air and detects reflected waves from an object. There are many applications for ultrasonic sensors, such as in intrusion alarm systems, automatic door openers and backup sensors for automobiles

Features of ultrasonic Sensors

- 1) Compact and light-weight
- 2) High sensitivity and high sound pressure
- 3) High reliability



International Journal of Innovative Research in Computer and Communication Engineering

(An ISO 3297: 2007 Certified Organization)

Website: www.ijircce.com

Vol. 5, Issue 3, March 2017

- **Wifi Module:**

The ESP8266 WiFi Module is a self-contained SOC with integrated TCP/IP protocol stack that can give any microcontroller access to your WiFi network. This module has a powerful enough on-board processing and storage capability that allows it to be integrated with the sensors and other application specific devices through its GPIOs with minimal development up-front and minimal loading during runtime. Its high degree of on-chip integration allows for minimal external circuitry, including the front-end module, is designed to occupy minimal PCB area.

- **Arduino:**

The Arduino Uno is a microcontroller board based on the ATmega328 . It has 14 digital input/output pins (of which 6 can be used as PWM outputs), 6 analog inputs, a 16 MHz crystal oscillator, a USB connection, a power jack, an ICSP header, and a reset button. It contains everything needed to support the microcontroller; simply connect it to a computer with a USB cable or power it with a AC-to-DC adapter or battery to get started. The Uno differs from all preceding boards in that it does not use the FTDI USB-to-serial driver chip. Instead, it features the Atmega8U2 programmed as a USB-to-serial converter.

IV.SIMULATION RESULTS

Carbon Dioxide Percentage Level bin-1:85%	Container Level bin-1:LOW
Carbon Dioxide Percentage Level bin-2:65%	Container Level bin-2:LOW

We are indicating Four levels Low,Medium,High and Full by using Embedded C programming. In first case when both the dustbins are empty webpage and LCD will display Low level.Then according to the different levels of garbage it will show Medium,High or Full level on LCD as well as webpage.

IV. CONCLUSION AND FUTURE WORK

This project work is the implementation of smart garbage management system using sensor, microcontroller and Wi-Fi module. This system assures the cleaning of dustbins soon when the garbage level reaches its maximum. This system also helps to monitor the fake reports and hence can reduce the corruption in the overall management system. This reduces the total number of trips of garbage collection vehicle and hence reduces the overall expenditure associated with the garbage collection. It ultimately helps to keep cleanliness in the society. Therefore, the smart garbage management system makes the garbage collection more efficient.

The scope for the future work is this system can be implemented with a system which can separate different types of garbage and also we can connect a display in vehicle so that the particular vehicle can collect the dust.

REFERENCES

1. Narayan Sharma,, "Smart Bin Implemented for Smart City",International Journal of Scientific & Engineering Research, Volume 6, Issue 9,September-2015
2. Conservation (GTEC 2011), 2011 International Conference Chennai 21 – 24
Vikrant Bhor, "Smart Garbage management System International Journal of Engineering Research & Technology (IJERT),Vol. 4 Issue 03,March-2015
3. KanchanMahajan, "Waste Bin Monitoring System UsingIntegrated Technologies", International Journal of Innovative Research in



ISSN(Online): 2320-9801
ISSN (Print): 2320-9798

International Journal of Innovative Research in Computer and Communication Engineering

(An ISO 3297: 2007 Certified Organization)

Website: www.ijirccce.com

Vol. 5, Issue 3, March 2017

4. Science, Engineering and Technology, Issue 3, Issue 7, July 2014.
Anjum Asma and Gihan Nagib, 'Energy Efficient Routing Algorithms for Mobile Ad Hoc Networks–A Survey', International Journal of Emerging Trends & Technology in computer Science, Vol.3, Issue 1, pp. 218-223, 2012.
M. Al-Maaded, N. K. Madi, RamazanKahraman, A. Hodzic, N. G. Ozerkan, An Overview of Solid Waste Management and Plastic Recycling in Qatar, Springer Journal of Polymers and the Environment, March 2012, Volume 20, Issue 1, pp 186-194.
5. Islam, M.S. Arebey, M. ;Hannan, M.A. ; Basri, H,"Overview for solid waste bin monitoring and collection system" Innovation Management and Technology Research (ICIMTR), 2012 International Conference, Malacca, 258 – 262
6. Raghmani Singh, C. Dey, M. Solid waste management of Thoubal Municipality, Manipur- a case study Green Technology and Environmental