



# International Journal of Innovative Research in Computer and Communication Engineering

(An ISO 3297: 2007 Certified Organization)

Website: [www.ijirccce.com](http://www.ijirccce.com)

Vol. 5, Issue 3, March 2017

## Centralized Software Based Task Delegation System for Teams of MNC Company

R S Amirtha<sup>1</sup>, P Nandhini Devi<sup>2</sup>, M.Suguna<sup>3</sup>

<sup>1,2</sup> UG Scholar, Department of Computer Science and Engineering, Kumaraguru College Of Technology, Coimbatore, Tamilnadu, India.

<sup>3</sup> Assistant Professor II, Department of Computer Science and Engineering, Kumaraguru College Of Technology, Coimbatore, Tamilnadu, India

**ABSTRACT:** Cloud computing plays an significant role on achieving better performance and high system utilization. The goal of a task delegation system is to perform task allocation, task scheduling in project efficiently and to implement it in the cloud as the project is distributed over different countries. The existing system involves manual integration of data and management of different-different processes, so it takes more time. The proposed system integrates system with human resource information, client management and project management at one place. It will reduce overall project cost, time, manual effort and ensures project completion in time. It uses the resources efficiently and allowing the employers to complete the particular task in the given period of time. Software projects are people-intensive activity and require employees with different skills, so task allocation scheduling are crucial phases in project. Task allocation is prepared by the Event based scheduler where the tasks are delegated to the employees based on their skills and availability and Tasks are assigned to the corresponding employee automatically as per the schedule . Using Event based scheduler, the different level of tasks are assigned automatically to the corresponding employees based on their efficiency. The proposed system calculate the efficiency of the employee using working hours based on which the task is allocated.

**KEYWORDS:** Task allocation, Event based scheduler , Efficiency and cloud computing.

### I.INTRODUCTION

Cloud computing is the environment which gives on-demand access of the network to a computing resources like storage, servers, applications and the other services which can be released minimum efficient way . user retrieved data and modified data which is stored by client advantages on-demand, efficient, reliable, low cost. It will put huge computational processing program automatically divide into numerous smaller subroutines through the network, then give the vast system which is composition of a number of servers to calculate. The processing result after calculation and analysis will back to the user. Cloud is a design where cloud service provider provides services to user on demand and it is also known as CSP stands for “cloud service provider”.

There are three service models of cloud,

- 1) Software as a service(SaaS)
- 2) Platform as a service(PaaS)
- 3) Infrastructure as a service(IaaS)

SaaS is the capability of using applications that are running on cloud environment. The users access these applications through internet connections. These kind of cloud offer the implementation of some specific business threads that gives specific cloud capabilities. PaaS gives the computational resources on which services and



# International Journal of Innovative Research in Computer and Communication Engineering

(An ISO 3297: 2007 Certified Organization)

Website: [www.ijircce.com](http://www.ijircce.com)

Vol. 5, Issue 3, March 2017

applications can host and develop. IaaS has capability of processing, storing and run software which is given to the consumer. It is also referred as the “Resource code” which provides resources as the services to the user. This work is done by the service provider. Scheduling is the process where tasks in the project are ordered to execute by the time. Allocation is the process where available resources in the project are assigned in order to execute the given task. The efficient task allocation mechanism can meet users requirements

and improve the resource utilization, thereby enhancing the overall performance of project management. Depending upon the employee efficiency, the level of task can be allocated. The levels of task are differentiated in to low, medium, high. By calculating work time of the employee, the efficiency is calculated and high level of task is assigned to the employee whose efficiency is high and low level of task is assigned to the employee with low efficiency. This allocation is automated by the Event based scheduler. In the EBS, the beginning time of the project, the time when resources are released from finished tasks, and the time when employees join or leave the project are regarded as events. The basic idea of the EBS is to adjust the allocation of employees at events and keep the allocation unchanged at nonevents. The proposed system helps project manager in allocating projects to employees based on their efficiency automatically and thus identifies the employee with high performance and ensures successful project completion.

The efficiency of individual employee is calculated and annual increments are given based on the efficiency.

## II. RELATED WORK

Jeffcoat and Bulfin in 1993 applied Simulated Annealing (SA) to resource scheduling. While SA is easy to code, more time is needed to compute quality solutions. In SA the constants used in the heuristic have affect the quality of the results, hence have to choose good precision. Tabu Search which is similar to SA, but, it generates many mutations at a time before shifting to the optimal solution. It saves the bad solutions in order to avoid traversing in future. Due to this, it avoids getting trapped into local minima. Genetic algorithm (GA) is an optimization technology. When GA is combined with heuristic methods, it works well for scheduling, but less optimal solutions may be accepted. Hill Climbing works as efficiently as SA where random restart variant of hill climbing is used. In general, there exists a trade-off between run time and solution quality in all the above methods.

## III. SYSTEM MODEL

Task allocation is prepared by the Event based scheduler where the tasks are delegated to the employees based on their skills and availability and Tasks are assigned to the corresponding employee automatically as per the schedule . Project Scheduling is the important phase in the project which can be performed by Event Based scheduler. A schedule is a listing of a project's milestones, activities, and deliverables, usually with intended start and finish dates.

# International Journal of Innovative Research in Computer and Communication Engineering

(An ISO 3297: 2007 Certified Organization)

Website: [www.ijirccce.com](http://www.ijirccce.com)

Vol. 5, Issue 3, March 2017

### 3.1 Architecture:

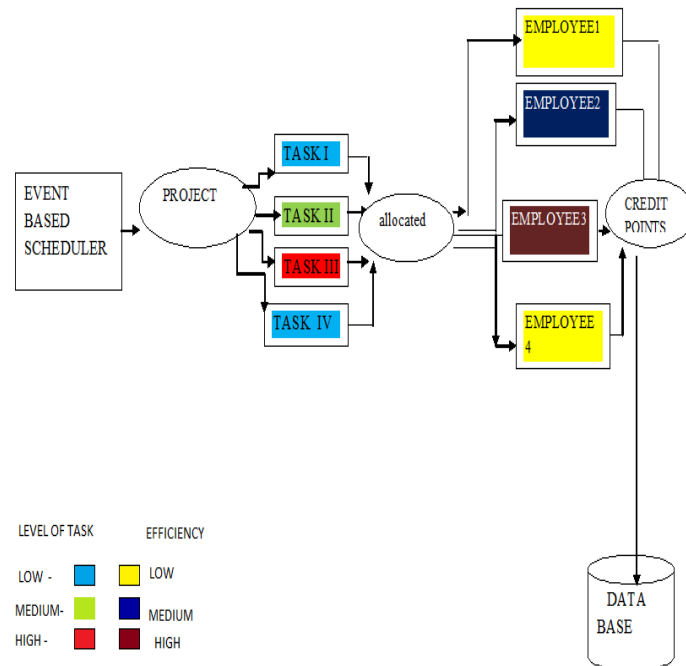

**Fig 1.EventBased Scheduler**

### 3.2 Work Break Down Structure:

Commits the individual who has the appropriate skills and expertise to the tasks requiring those skills.. Organization calls for the appointment of one man, the project manager, who has the responsibility for the detailed planning, coordination and ultimate outcome of the project. The project manager should perform the following actions before the commencement of the project. Resource Planning which is determining what recourses (people, equipment, materials) and what quantities of each should be used to perform project activities. Cost Estimating, that means developing an estimate of the costs of the recourses needed to complete project activities. Analysis & break down of project into smaller pieces of work Development of checklist of everything that needs to be done. Selection of team members,. This is an important role for project manager. Initially the project is divided into tasks and assigned to the employees by the project manager and followed by automation

### 3.3 Event Based Scheduling:

The main aim of EBS is to improve the allocation whenever events occur and set it constant when events do not occur. The events are Starting of the project, Resource released by completed task, Employee comes and leaves the project. In EBS, tasks are scheduled to the available resources to complete the projects.

Steps to represent scheduling:

1. Determining sequence of work.
2. Building interdependence
3. Estimation of total duration and determination of Critical Path of tasks to be done in order



# International Journal of Innovative Research in Computer and Communication Engineering

(An ISO 3297: 2007 Certified Organization)

Website: [www.ijirccce.com](http://www.ijirccce.com)

Vol. 5, Issue 3, March 2017

#### 4. Establish milestones

The above actions are performed by project manager.

Determining human resources to cross milestones, which is done by Event Based Scheduler.

Task allocation is automated by the following algorithm.

#### **EBS Algorithm:**

Step 1: Initialize the no of available employees

Step 2: Identify the task

Step 3: If the planned working hours is lesser than the remaining working hours of the employee, planned working hours of the particular task is assigned to the no of working hours of the that employee for the task j

Step 4: Else, the number of working hours of the that employee for the task j is set to the remaining working hours of the that employee at t.

Step 5: Compute the completion status of the task at time t

Step 6: If any task is completed at t, set t+1 as event

Step 7: next,t is incremented

The above algorithm allocates tasks automatically to the employee based on their availability and efficiency.

#### **3.4 Efficiency calculation:**

The efficiency of the employee is calculated by the working hours for a particular task. If employee finish the task before the end time of the task, his efficiency is high and higher level of task is automatically assigned to him. So the tasks are differentiated into low, medium, high and according to the efficiency the corresponding task is assigned. Based on efficiency the credit points are added to the database for particular employee and the annual increments are computed for individual employee based on credit points. So individual employee's performance is tracked for all project he has completed.

#### **3.5 Implementation in Cloud:**

As the project in MNC Company is distributed over different countries, the proposed application should be stored in cloud. So that the application can be used and data can be shared by the team members at different countries.

## **IV. PROPOSED SYSTEM**

The information can be stored in centralized database which can be maintained by the system. Authentication is provided for this application, so only registered members make any changes in the database. The new system requires integrating systems for Human Resource. Information, Client management and Project management at one place. The proposed system reduced the manual effort by automatic allocation..Here, the proposed system uses Event Based Scheduler which consider the beginning time of the project, the time when resources are released from finished tasks, and the time when employees join or leave the project and efficiency of employee to allocate the task. So the project can be completed in a efficient way. The efficiency of individual employee is computed and rewarded.

## **V. CONCLUSION**

Therefore, the centralized software task delegation system achieves the project completion on time and reduces project cost, time and manual effort. As the proposed web application combines with cloud computing, it is used across different countries where employees can share the data that helps working in same project efficiently. Existing systems consider beginning time of project, availability of employee and resources availability to allocate tasks. But In



ISSN(Online): 2320-9801  
ISSN (Print): 2320-9798

# International Journal of Innovative Research in Computer and Communication Engineering

(An ISO 3297: 2007 Certified Organization)

Website: [www.ijirccce.com](http://www.ijirccce.com)

Vol. 5, Issue 3, March 2017

proposed system, Event Based Scheduler consider efficiency of employee besides the above events, so it promises efficient project completion.

## REFERENCES

- [1] Prajakta Joglekar, Pallavi Jaiswal, Vandana Jagta, "Study of Project Scheduling And Resource Allocation Using Ant Colony Optimization "International Journal Of Current Engineering and Scientific Research (2015)
- [2] Arjita Sharma, Niyati R Bhele, Snehal S Dhamale, Bharati Parkhe "A Proposed Scheme For Software Project Scheduling And Allocation With Event Based Scheduler Using Ant Colony Optimization "International Journal Of Application Or Innovation In Engineering & Management (2015)
- [3] C. Chantrapomchai, D. Sawangkokrouk and T. Leadprathom "Project Management Software: Allocation And Scheduling Aspects, International Journal Of U- And E- Service, Science and Technology (2013)
- [4] Vivek Kurien, Rashmi S Nair "Software Project Planning and Resource Allocation Using Ant Colony Optimization With Uncertainty Handling ", Toc H Institute Of Science & Technology, Kerala (2014).
- [5] Massimiliano Di Penta , Mark Harman, And Giuliano Antoniol "The Use Of Search-Based Optimization Techniques To Schedule And Staff Software Projects: An Approach And An Empirical Study" , Software—Practice And Experience,Pp.1-7,(2009).
- [6] Cristina Selaru, Msc Student, "Resource Allocation In Project Management", International Journal Of Economic Practices and Theories,(2012).
- [7] Jinn-Tsong Tsai A,N , Jia-Cen Fang A , Jyh-Hornng Chou," Optimized Task Scheduling And Resource Allocation On Cloud Computing Environment Using Improved Differential Evolution Algorithm ",Computers & Operations Research (2013).
- [8] Timothy W. Rauenbusch And Kenneth Conley "Tracking And Learning Acceptance Criteria For Delegated Tasks", Artificial Intelligence Centre SRI International Menlo Park,(2007).
- [9] Jihun Park, Dongwon Seo, Gwangui Hong, Donghwan Shin, Jimin Hwa, Doo-Hwan Bae," Practical Human Resource Allocation In Software Projects Using Genetic Algorithm ",Korea Advanced Institute Of Science And Technology.
- [10] Nandkishor Patil , Kedar Sawant , Pratik Warade , Yogesh Shinde, "Survey Paper For Software Project Scheduling And Staffing Problem", International Journal Of Advanced Research In Computer And Communication Engineering,(2014).