



A Review on Power Factor Control Techniques for DC-DC Converters

Apurva Patel¹ Vaishali Patel²

PG Student, Department of Electrical, Merchant Engineering College, Basna, India¹

Assistant Professor, Department of Electrical, Merchant Engineering College, Basna, India²

ABSTRACT: The importance of power-factor correction and the related line-harmonics reduction is increasing as the amount of line-fed electronic equipment grows and the requirements of regulatory agencies tighten. In this paper a comprehensive overview of power-factor correction in DC-DC converters, including the definition of power factor and its relation to total harmonic distortion; many passive and active power-factor corrector topologies and control methods; modelling issues reviewed.

KEYWORDS: DC-DC converters, PFC, THD, CCM, DCM

I. INTRODUCTION

DC-DC converters are one of the important electronic circuits, which are widely used in power electronics. The main problem with operation of DC-DC converter is unregulated power supply, which leads to improper function of DC – DC converters. There are various analogue and digital control methods used for dc-dc converters and some have been adopted by industry including voltage- and current-mode control techniques. The DC-DC converter inputs are generally unregulated dc voltage input and the required outputs should be a constant or fixed voltage. Application of a voltage regulator is that it should maintains a constant or fixed output voltage irrespective of variation in load current or input voltage. Various kinds of voltage regulators with a variety of control schemes are used to enhance the efficiency of DC-DC converters. Today due to the advancement in power electronics and improved technology a more severe requirement for accurate and reliable regulation is desired. This has led to need for more advanced and reliable design of controller for dc-dc converters. There are various types of DC-DC converters required for particular purpose like Buck, Boost, Buck and Boost, Ćuk and Flyback. These all DC-DC converters have their specific configurations to complete their tasks. Varieties in DC-DC converter required different type of controlling techniques because single technique cannot be applied to all converters as the all have different specifications. Aim of this paper is to have an overview of all the control techniques used to ease the performance of various kinds of DC-DC converters. We will briefly discuss the basic concept, advantages and disadvantage of each control technique throughout this review.

II. POWER FACTOR CONTROL TECHNIQUES

Power Factor Correction is a technique that promotes efficient energy consumption from the power grid. Power Factor correction is employed inside common electrical and electronic equipment that are powered from the AC outlet. Power factor correction enables the equipment to maximize the active power draw and minimize the reactive power draw from the AC outlet. To operate the converter as a power factor corrector, consider continuous conduction mode: as the current stress and current ripple are minimum in this mode. A number of continuous inductor current mode control strategies such as average voltage control, hysteresis current control, and non-linear control techniques are reviewed in this paper.

a.) Average Voltage Control

In most of the power electronic converter applications the output variable is the voltage and is involved in the outer loop. The variable within the inner loop is current, this is the reason this technique is called as average current control technique. The average current controlled interleaved boost PFC converter, is designed to

International Journal of Innovative Research in Computer and Communication Engineering

(An ISO 3297: 2007 Certified Organization)

Website: www.ijircce.com

Vol. 5, Issue 3, March 2017

operate in CCM, it may transit to DCM when the load becomes light. Figure 1. shows the main circuit and control block diagram of the average current controlled converter. It uses voltage control loop and current control loop.

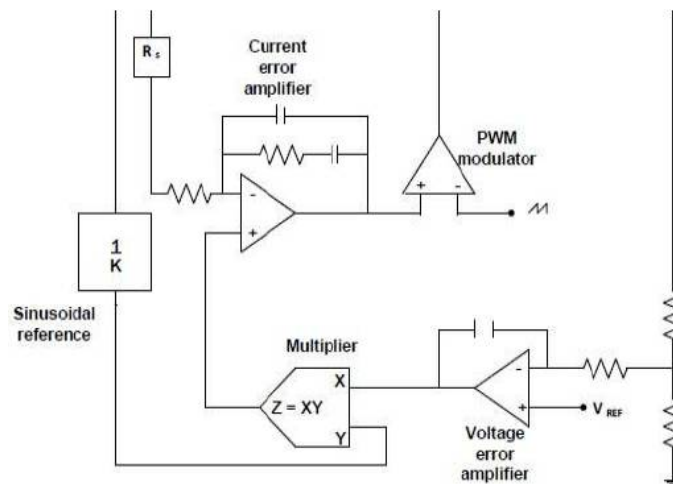

Fig.1. Control circuit for average voltage control

Advantages:

- Constant switching frequency;
- No need of compensation ramp;
- Control is less sensitive to commutation noises, due to current filtering;
- better input current waveforms than for the peak current control since, near the zero crossing of the line voltage, the duty cycle is close to one, so reducing the dead angle in the input current [4].

Disadvantages:

- Inductor current must be sensed; a current error amplifier is needed and its compensation network design must take into account the different converter operating points during the line cycle. This control technique is becoming very popular and detailed design criteria can be found in [4, 7, 8, and 10].

b.) Hysteresis Current Control

Among the various control methods, hysteresis current control[7] is the extensively used technique owing to its noncomplex implementation, enhanced system stability, fast response, less distortion in input current waveform and regulating the output voltage.

International Journal of Innovative Research in Computer and Communication Engineering

(An ISO 3297: 2007 Certified Organization)

Website: www.ijirccce.com

Vol. 5, Issue 3, March 2017

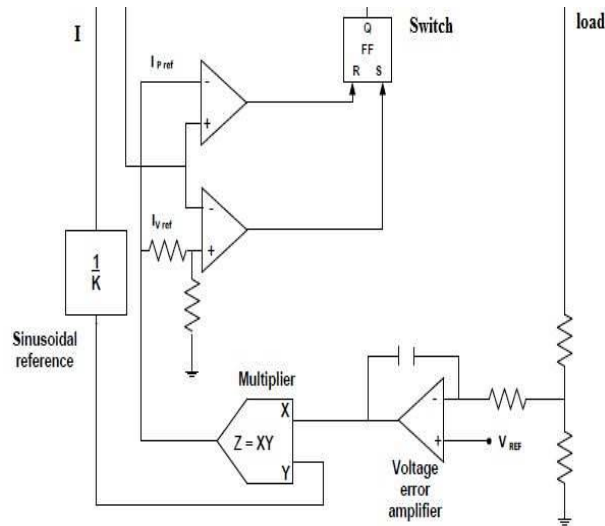

Fig.2. Control circuit for hysteresis control^[7]

This technique is believed to exhibit greater stability. According to this control technique, when the inductance current is less than the lower current reference, power switch is turned ON and when the inductance current is more than the upper current reference, power switch is turned OFF. The boost converter is being operated at continuous current mode (CCM). For the hysteresis control, the inductance current is switching at a variable switching frequency. The switch must be turned ON while zero crossing of the line voltage for restraining very high switching frequency. In order to avoid too high switching frequency, the switch can be kept open near the zero crossing of the line voltage so introducing dead times in the line current.

Advantages:

- no need of compensation ramp;
- low distorted input current waveforms.

Disadvantages:

- variable switching frequency;
- inductor current must be sensed;
- control sensitive to commutation noises.

c.) Non linear Carrier Control

Nonlinear carrier controllers are proposed for high power factor boost rectifiers with low total harmonic distortion [8]. In this type of controllers, the duty ratio is determined by comparing a signal derived from the main switch current with a periodic nonlinear carrier waveform. As a result, the average input current follows the input line voltage. This technique is suitable for boost converters operating in the continuous conduction mode. The proposed controller obtains the duty ratio in each switching period from the comparison of the negative ramp carrier waveform and the sensed inductor current signal as shown in Figure 3, and sensed switch current signal as shown in Figure 4.

International Journal of Innovative Research in Computer and Communication Engineering

(An ISO 3297: 2007 Certified Organization)

Website: www.ijircce.com

Vol. 5, Issue 3, March 2017

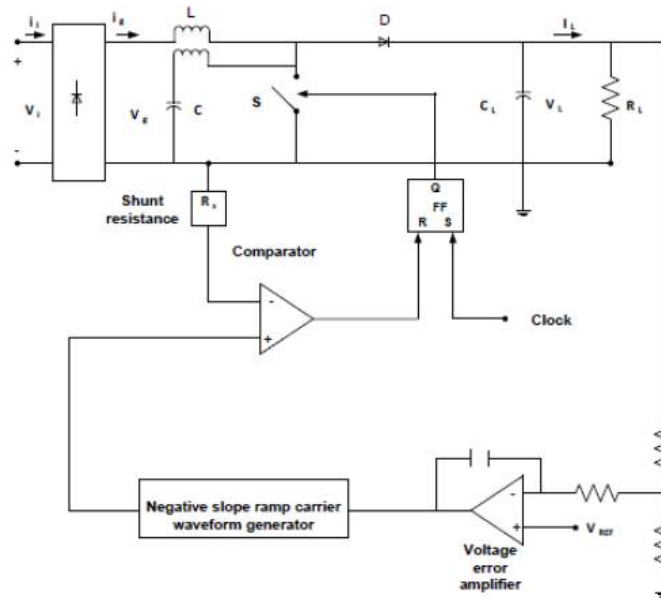

Fig.3. Control circuit for non-linear current control^[8]

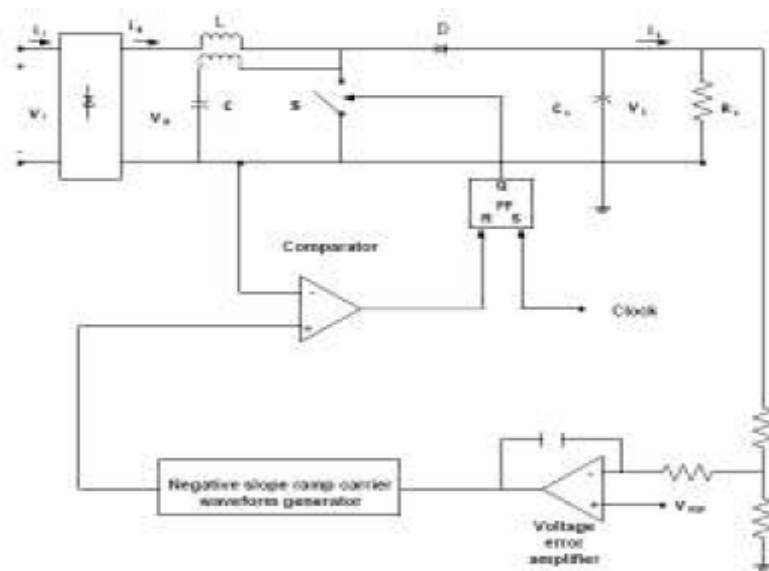

Fig.4. Control circuit for non-linear current technique-inductor current sensing^[8].

so, the input voltage sensor, the error amplifier in the current feedback loop, and the multiplier as used in the conventional control technique are not required.



International Journal of Innovative Research in Computer and Communication Engineering

(An ISO 3297: 2007 Certified Organization)

Website: www.ijircce.com

Vol. 5, Issue 3, March 2017

III. CONCLUSION

In this paper we review on power factor control techniques used for DC-DC converters. Also we briefly explained the basic concepts of each control techniques.

REFERENCES

1. L. Rossetto, G. Spiazzi, P. Tenti, "control techniques for power factor correction converters.
2. Zhou, C., Ridley, R.B. and Lee, F.C. (1990) "Design and Analysis of a Hysteretic Boost Power Factor Correction Circuit", 21st Annual IEEE Power Electronics Specialists Conference, San Antonio, 11-14 Jun 1990, 800-807.
3. Maksimovic, D., Yungtaeklang and Erickson, R.W. (1995) "Nonlinear-Carrier Control for High Power Factor Boost Rectifiers", 10th Annual Applied Power Electronics Conference and Exposition, 2, 635-641.
4. Miwa, B.A., Otten, D. and Schlecht, M.E. (1992), "High Efficiency Power Factor Correction Using Interleaving Techniques", Proceedings of the 7th Annual Applied Power Electronics Conference and Exposition, Boston, 23-27 February 1992, 557-568.
5. M. Brkovic, S. ČUK, "Input Current Shaper using ČUK Converter", INTELEC Conf.Proc., pp. 532-539, 1992.
6. J. Klein, M. K. Nalbant, "Power Factor Correction - Incentives, Standards and Techniques", PCIM Conf. proc., 1990, pp. 26,28-31.
7. B. Andreyčak, "Optimizing Performance in UC3854 Power Factor Correction Applications", Unitrode, Products & Applications Handbook, 1993/94.
8. Rashid M.H., Power Electronics: Circuits, Devices and Applications vol. (3rd Edition), Prentice Hall (2003).
9. Robert W. Erickson, Fundamentals of Power Electronics," 2nd Edition, Kluwer Academic Publishers.
10. Chen Z., Wu Q., Li M., Xu Y., Wang Q., "A three-port DC-DC converter with low frequency current ripple reduction technique.", APEC; 2015: 2069 - 2074.
11. C. A. Canesin, I. Barbi, "A Unity Power Factor Multiple Isolated Outputs Switching Mode Power Supply Using a Single Switch", APEC Conf. Proc., 1991, pp. 430-436.
12. R. B. Ridley "Average Small-Signal Analysis of the Boost Power Factor Correction Circuit", VPEC Seminar Proceedings, 1989, pp. 108-120.
13. B. Andreyčak, "Optimizing Performance in UC3854 Power Factor Correction Applications", Unitrode, Products & Applications Handbook, 1993/94.

BIOGRAPHY

Apurva J. Patel has received his Bachelor degree in Electrical Engineering from Gujarat University, Ahmedabad, India. Currently she is pursuing M.E (Power system engineering) from Gujarat Technological University. His area of interest include Power System.

Mrs. Vaishali Y. Patel has received the B.E. and M.E. degrees in Electrical Engineering Gujarat, India. Currently she is working as an Assistant Professor in MEC, Basna, Gujarat.