



IJIRCCCE

e-ISSN: 2320-9801 | p-ISSN: 2320-9798



INTERNATIONAL JOURNAL OF INNOVATIVE RESEARCH

IN COMPUTER & COMMUNICATION ENGINEERING

Volume 11, Issue 4, April 2023

ISSN INTERNATIONAL
STANDARD
SERIAL
NUMBER
INDIA

Impact Factor: 8.379



9940 572 462



6381 907 438



ijircce@gmail.com



www.ijircce.com

Automatic Hand Sanitizer Dispenser Using Arduino

Mule Sakshi^{1*}, Adsul Sakshi^{2*}, Kabhare Pooja^{3*}, Gaikwad Nachiketa^{4*}, Mr. Panke S. R.

¹⁻⁴Department of Electronics and Telecommunication Engineering, Govt. Polytechnic, India

⁵Head of Department of Electronics and Telecommunication Engineering, Govt. Polytechnic

Osmanabad, India

ABSTRACT: COVID pandemic has influenced human life in individual sectors. Various attempts were made to shorten the virus transferring by work from home (WFH), social distancing, and besides including hand hygiene. As COVID-19 are transferrable through touch and contact, there are WHO guidelines to immaculate or sanitize hands regularly to reduce the risk of infection. Dispensing of sanitizer from bottle and storage would require manual intervention. In addition, so far, most of the available hand sanitizers do not operate automatically. This article aims to make an automatic hand sanitizer, which finds its use in hospitals, work places, offices, schools and much more to reduce the risk due to contact. Here, the system can sense the proximity with the help of ultrasonic sensor and sends signal to microcontroller (Arduino Nano). The controller processes the sensor data & actuates the pump and solenoid valve. In addition, the result is the sanitizer liquid dispenses through mist nozzle.

I. INTRODUCTION

1.1 Research Background

Hygiene is an important aspect to remain healthy. There are various aspects of hygiene. A clean hand is one of them. Hands generally are touched at various surfaces and can be exposed to direct contamination. Cleaning hands at regular interval is recommended by various health organizations including WHOM. Hand hygiene is now regarded as one of the most important element of infection control activities. In the wake of the growing burden of health care associated infections (HCAIs), the increasing severity of illness and complexity of treatment, superimposed by multi-drug resistant (MDR) pathogen infections, health care practitioners (HCPs) are reversing back to the basics of infection preventions by simple measures like hand hygiene. This is because enough scientific evidence supports the observation that if properly implemented, hand hygiene alone can significantly reduce the risk of cross-transmission of infection in healthcare facilities (HCFs) [1-5]. Evidence suggests that hand sanitization significantly reduces the transmission of healthcare-associated pathogens and the incidence of HCAI (healthcare associated infections) [6]. According to the Centre for Disease Control and Prevention (CDC), hand hygiene encompasses the cleansing of your hands using soap and water, antiseptic hand washes, alcohol-based hand sanitizers (ABHS), or surgical hand antiseptics. These days, alcohol-based hand sanitizers are increasingly being used instead of soap and water for hand hygiene in healthcare settings. Poor or inadequate hand washing and/or hand hygiene is known to be problematic in hospital settings, and is a major source of infections contracted while patients are admitted to a hospital. While hand washing and hygiene policies and training are important and can be effective in reducing the spread of infections, the problem of infections due to unsatisfactory hygiene of staff, medical professionals, and even patients continues to be problematic. It is known to place hand washing stations and hand sanitizer dispensers throughout medical facilities including in examination rooms, hallways, lobbies, and even patient rooms. However, such systems are purely mechanical and are incapable of providing an automated means of establishing accountability of good hygienic practices [7]. During the last quarter of 2019, a collection of unusual pneumonia cases went from a local concern to a global pandemic in a matter of 70 days. The infamous Severe Acute Respiratory Syndrome Coronavirus 2 (SARS-CoV-2) is the virus [8] that was first reported in Wuhan, China on December 31, 2019, and was announced as a pandemic by the World Health Organization on March 11, 2020. This virus is zoonotic (a virus that is transmitted between animals and humans) and originates from bats [9]. Besides, this virus can also be transmitted from humans to humans. Coronavirus can be transmitted either by air, direct contact, or indirectly. However, it is most commonly spread by droplets. Symptoms caused by this virus include the mild flu, namely a cold, sore throat, cough, fever, and difficulty breathing. In severe cases, Covid-19 can manifest as pneumonia. Patients can develop acute respiratory distress syndrome for a short time and die from multiple organ failure [10]. The existence of this disease has a big impact on both socials and economics. WHO has declared this a pandemic disease and many cities around the world are in a lockdown situation. To prevent the cause of this virus, it can be done by keeping a distance at least 1 meter, avoid going to crowded places, avoid touching the eyes, mouth,

and nose when outside, and cleaning hands with soap or alcohol-based hand rub [11]. Providing containers for cleaning fluids in public spaces is a form of Covid-19 prevention, but the provision of containers is currently ineffective because there are parts that are often touched. This could be a point of transmission for Covid-19. Many health actions are carried out using automatic systems including air quality monitoring [12], hand sanitizers [13], hand hygiene [14]. Hand sanitizers are an alternative for washing hands during a pandemic. It can be used when and water are not available. Hand sanitizer is also available in several forms such as liquid (spray) or gel [15]. Hand sanitizer is usually made from materials such as alcohol, polyacrylic acid; glycerine, propylene glycol, or plant extracts [16]. The process of killing germs starts with removing the oil on the skin, then the bacteria in the body will come to the surface. Soap or alcohol will kill bacteria after rubbing to your hand. Hand sanitizer is effective against Covid-19. So far, most of the available hand sanitizers do not operate automatically. This article aims to make an automatic hand sanitizer where sanitizer liquid can come out automatically. Here, the circuit includes an ultrasonic sensor SC-04. The sensor senses the proximity of hands under the machine. The machine is designed for wall mount at a height of 4ft such that anyone can reach to get sanitizer dispense. The sensor send signal to the microcontroller and the controller takes decision to actuate the pump and valve simultaneously to dispense the liquid sanitizer through a mist nozzle.

II. LITERATURE SURVEY

The paper says about emergence of the novel Coronavirus (SARS-CoV2), which has caused unexpected challenges to health of the people of this world, the paper also aims at reducing the transmission rate of the disease. In the absence of availability of vaccine or effective antiviral drugs, hand hygiene is a mainstay of efforts to prevent the spread of severe acute respiratory syndrome corona virus 2 (SARS-CoV-2), the virus that causes COVID-19. In the hand sanitizer study, the researchers evaluated the effectiveness of different concentrations of two WHO-recommended and two modified hand sanitizer formulations on COVID-19 virus. The WHO recommends two formulas: (1). 80% ethanol, 1.45% glycerol and 0.125% hydrogen peroxide and (2). 75% 2-propanol, 1.45% glycerol and 0.125% hydrogen peroxide. However, these formulas failed to meet the effectiveness requirements of European Norm 1500. So, the modified versions used in this study was (1). 80% ethanol, 0.725% glycerol and 0.125% hydrogen peroxide and (2). 75% 2-propanol, 0.725% glycerol and 0.125% hydrogen peroxide. It has been found that WHO formulation had a virus reduction factor of ≥ 3.8 , while the modified versions had a reduction factor of ≥ 5.9 . [17] This paper showed the effectiveness of the alcohol based hand sanitizers, which reduced infection rates by whopping 30%. The paper also explains about the virus structure and how it is different from that of the bacterial structure, which means that virus has single stranded or double stranded RNA or DNA encapsulated in 'capsid' and virus can replicate only in presence of a host and described as 'living entities'. Bacteria also has almost the same structure including DNA or RNA along with 'Cell Membrane' and can replicate without a host. The paper also gives a complete comparison between hand sanitizers and soap, foam vs. gel, and it says that high concentration of ethanol can reduce the amount of virus particle present in the hand and hence proves the effectiveness of alcohol based hand sanitizer.

III. PROPOSED SYSTEM

Several steps were carried out in this research to test the Automatic hand sanitizer container has shown in Figure.1. Due to the spread of Covid disease, first we analyse the importance of environment needed for automatic hand sanitizer. The second step we make the literature study about the related article. We design the hardware, examine the product and report the result. Here is the flowchart of the events as follows: case analysis => research reference => design & modelling => creating an algorithm => connecting hardware => fabrication => testing & debugging => finish report

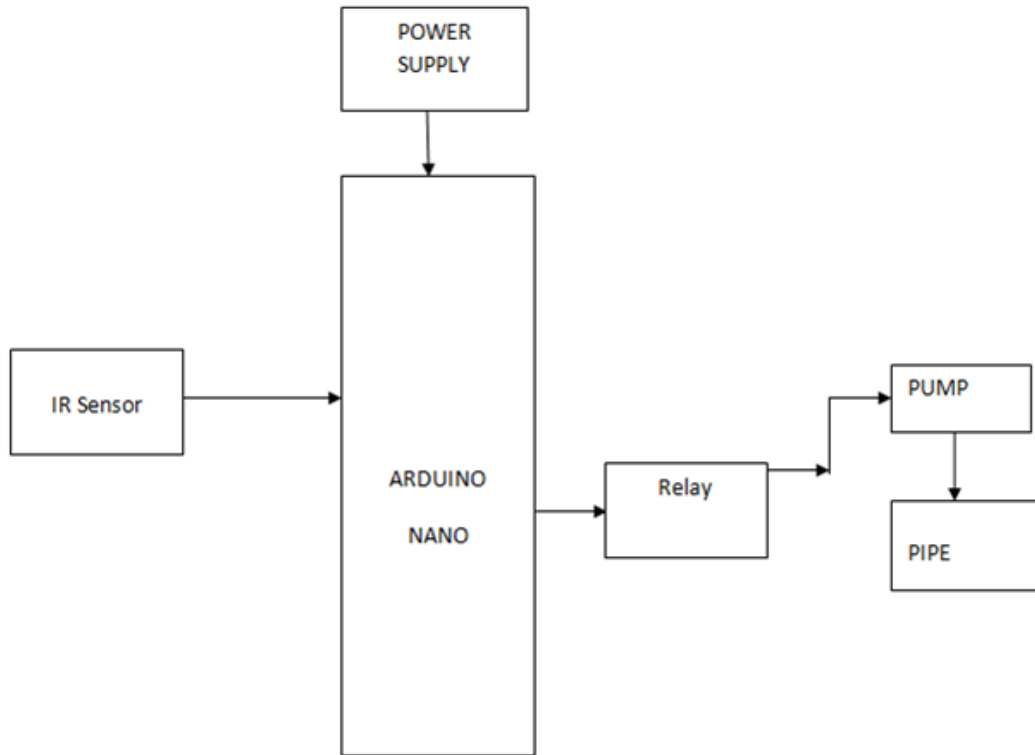

Fig 1: Block Diagram of Automatic Hand Sanitizer Dispenser Using Arduino

Here, An Arduino Nano microcontroller is used since it is easy to program, has inbuilt ADC, DAC. The input to the Arduino is given using an ultrasonic sensor, which is used to sense the distance, it emits ultrasonic frequency from one side and the notes the time taken by sound wave to get reflected back. The ultrasonic sensor is used to detect hands with a distance of approximately 7 cm from the sensor. If a human hand has been detected, the sensor will send input to the Arduino Nano as a microcontroller (central controller). The Arduino Nano microcontroller is the control main which has a program to access data from the input of the ultrasonic sensor. The Arduino gives a 100ms pulse from it's digital output pin. The pump cannot be used directly, hence a relay is used as a switch. The relay accepts the pulse from Arduino and makes the pump run. The pump is 3V to 6V submersible type, which pumps out a few drops of hand sanitizer on to the hands, after pumping, the distance is sensed for every 1000ms(1s) for scanning purposes.

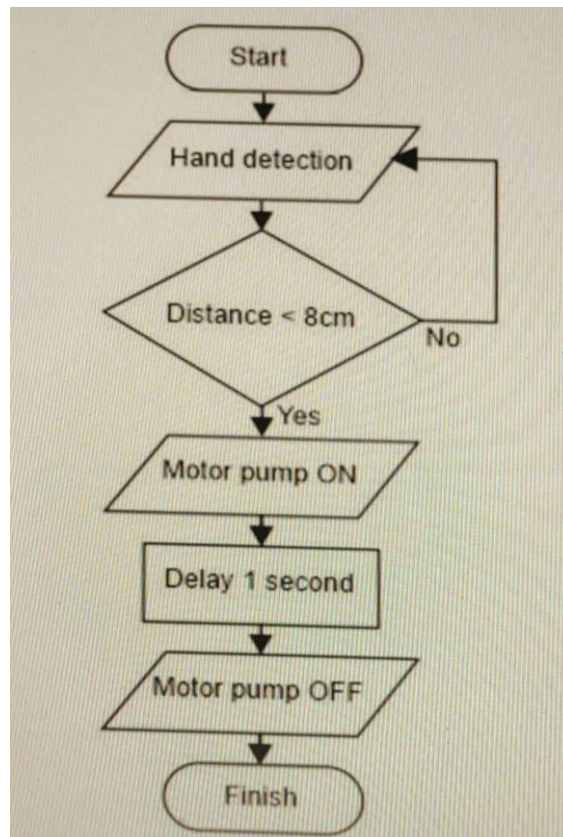

Fig 2: Flow Chart

1.4 Working Principle

At first, the device should be plugged in using a 12 V AC-DC adapter. Then the process will automatically start to run without any human interaction. The functionality of this dispenser device is simple. Whenever the user puts his/her hand at a distance less than 3 cm, the ultrasonic sensor detects it. The signal from the ultrasonic sensor is then processed and obtained in the Arduino Microcontroller. After that, Arduino will send an output signal to the motor driver. The motor driver is used to turn on the pump motor when getting commands from the microcontroller. The motor driver is used because the microcontroller cannot directly turn on the pump motor. After the pump motor runs for pre-programmed time of 1 (one) second, it turns off automatically and stops the flow of sanitizer. The hand sanitizer is equipped with a safety device in the form of hand detection which must be more than 1 (one) second in order not to waste the hand sanitizer unnecessarily. One time filling of hand sanitizer liquid can be used up to approximately 400 times.

IV. SIMULATION RESULTS

Testing of automatic hand sanitizer tools is carried out by testing the performance of automatic hand sanitizer. Testing of the automatic hand sanitizer tool is in the form of testing the success rate of the tool. In the above paper, Arduino is used as a microcontroller for calculating the distance between the sensor and the hand placed below it. If it is less than 7cm, then pump runs for 100ms through a relay and pumps out few mL of liquid alcohol based hand sanitizer and also senses the distance for every 1000ms. Components like pump, relay, Arduino microcontroller were tested. Testing is done by testing the ultrasonic sensor by placing your hands at a certain distance, namely 5 cm, 7 cm, and 10 cm. The test was carried out on 10 people with 10 detections for each person and the distance between the hands and the sensor.

Respondent	The Success Tool		
	5 cm	7 cm	10 cm
Respondent 1	100%	100%	0%
Respondent 2	100%	100%	0%
Respondent 3	100%	100%	0%
Respondent 4	100%	100%	0%
Respondent 5	100%	100%	0%
Respondent 6	90%	100%	0%
Respondent 7	100%	100%	0%
Respondent 8	100%	100%	0%
Respondent 9	100%	100%	0%
Respondent 10	100%	100%	0%
Respondent 11	100%	100%	0%

Fig 3 : Success Rate Of Hand Sanitizer

Based on Table, it shows that the automatic hand sanitizer sensor will work properly when the hand is at a distance of 7 cm. The successful discharge rate of hand sanitizer reaches 100%. The success rate of automatic hand sanitizer with a hand distance of 5 cm from the sensor reaches 90%. While the success rate of automatic hand sanitizer with a hand distance of 10 cm from the sensor reaches 0%. This is because the program is set at 7 cm to match the hand sanitizer fluid discharge pipe. The program distance can be adjusted via the Arduino program.

V. CONCLUSION

The paper says that non contact dispensing is very important to prevent pathogen spreading and finally, hand hygiene is most important and must be part of our daily life. In this study, a novel design of an automated hand sanitizer dispenser was demonstrated. The components needed for the device fabrication were described in detail. The circuit diagram was discussed, which clarifies the connection between the components with the microcontroller circuit (Arduino Nano). The piping conditions were shown and described accordingly. The relevant diagrams and components of the original device were presented in sequential order for a better understanding. Arduino Nano was used to input the program into the microcontroller. The algorithm used in this device was described with a flowchart to depict the functionality of the dispenser. Based on the results of the research on the design of the automatic hand sanitizer that the researchers did, it can be concluded that the hand sanitizer can work well when the hands are at a distance of 7 cm. According to the researchers, 7 cm is considered ideal because it has been adjusted to the discharge pipe for the hand sanitizer. The hand sanitizer can be active for approximately 20 hours and one time filling of the hand sanitizer liquid can be used up to 400 times.

REFERENCES

1. Guide to implementation of the WHO multimodal hand hygiene improvement strategy. Available from: <http://www.who.int/patientsafety/en/> , accessed on August 24, 2010.
2. WHO Guidelines on Hand Hygiene in Health Care. First Global Patient Safety Challenge. Clean Care is Safer Care. Available from: <http://www.who.int/patientsafety/en/> , accessed on August 24, 2010.
3. Boyce JM, Pittet D. Guideline for Hand Hygiene in Health-Care Settings. Recommendations of the Healthcare Infection Control Practices Advisory Committee and the HICPAC/SHEA/APIC/IDSA Hand Hygiene Task Force. PubMed, Google Scholar, Morb Mortal Wkly Rep. 2002;51:1–44.
4. Kampf G, Kramer A. Epidemiologic background of Hand Hygiene and evaluation of the most important agents for scrubs and rubs. Clin Microbiol Rev. 2004;17:863–93.
5. Daniels IR, Rees BI. Handwashing: simple, but effective. Ann R Coll Surg Engl. 1999;81:117–8.
6. Sickbert-Bennett EE, DiBiase LM, Willis TM, Wolak ES, Weber DJ, Rutala WA. Reduction of Healthcare-Associated Infections by Exceeding High Compliance with Hand Hygiene Practices. Emerging Infect. Dis. 2016 Sep;22(9):1628-30.
7. Knighton, 2013, Patent, google patent search.
8. World Health Organization 2020 Naming the Coronavirus Disease (COVID-19) and The Virus that Causes it (Internet) WORLD Health Organization, Available on [https://www.who.int/emergencies/diseases/novel-coronavirus2019/technical-guidance/naming-the-coronavirus-disease-\(COVID-2019\)-and-thevirus-that-causes-it](https://www.who.int/emergencies/diseases/novel-coronavirus2019/technical-guidance/naming-the-coronavirus-disease-(COVID-2019)-and-thevirus-that-causes-it).

9. Zakir K, Khayal M, Ali A, Hazir R March 2020 Coronavirus Outbreaks: Prevention and Management Recommendations, Drugs & Therapy Perspectives
10. Yan-R G, Qing-D C, et al 2020 The Origin, Transmission, and Clinical Therapies on Coronavirus Disease 2019 (Covid-19) Outbreak An Update on The Status, Military Medical Research 7.
11. World Health Organization 2020 Naming the Coronavirus Disease (COVID-19) and The Virus that Causes it (Internet) WORLD Health Organization Available on <https://www.who.int/emergencies/diseases/novel-coronavirus2019/advice-for-public>.
12. “Construction and Application of an Intelligent Air Quality Monitoring System for Healthcare Environment,” 2014, DOI: 10.1007/s10916-0140015-3.
13. T. S. Hong et al., “Systems-Level Quality Improvement A Hand Hygiene Compliance Check System :Brief Communication on a System to Improve Hand Hygiene Compliance in Hospitals and Reduce Infection,” 2015, DOI: 10.1007/s10916-015-0253-z.
14. S. Angelina et al., “Infection Prevention in Practice Assessing the Hawthorne effect on hand hygiene compliance in an intensive care unit,” vol. 2, pp. 10–13, 2020, DOI: 10.1016/j.infpip.2020.100049.
15. Aliya H June 2016 Antibacterial Effectiveness of Commercially Available Hand Sanitizers International Journal of Biology and Biotechnology.
16. Sally F B, Allison E A. et. Al 2007 The Effectiveness of Hand Hygiene Procedures in Reducing The Risks of Interactions in Home and Community Settings Including Hand washing and Alcohol-based Hand Sanitizers American Journal of Infection Control.
17. The study was published online in the Journal of Hospital Infection.
18. Pittet, D.; Hugonnet, S.; Harbarth, S.; Mourouga, P.; Sauvan, V.; Touveneau, S.; Perneger, T.V. Effectiveness of a hospital-wide programme to improve compliance with hand hygiene. *Lancet* 2000, 356, 1307–1312. [CrossRef]
19. Larson, E.L.; Eke, P.I.; Laughon, B.E. Efficacy of alcoholbased hand rinses under frequent-use conditions. *Antimicrob. Agents Chemother.* 1986, 30, 542–544. [CrossRef]
20. Larson, E.L.; Aiello, A.E.; Bastyr, J.; Lyle, C.; Stahl, J.; Cronquist, A.; Lai, L.; Della-Latta, P. Assessment of two hand hygiene regimens for intensive care unit personnel. *Crit. Care Med.* 2001, 29, 944–951. [CrossRef] [PubMed]
21. Widmer, A.F. Replace hand washing with use of a waterless alcohol hand rub? *Clin. Infect. Dis.* 2000, 31, 136–143. [CrossRef] [PubMed]
22. Maury, E.; Alzieu, M.; Baudel, J.L.; Haram, N.; Barbut, F.; Guidet, B.; Offenstadt, G. Availability of an alcohol solution can improve hand disinfection compliance in an intensive care unit. *Am. J. Respir. Crit. Care Med.* 2000, 162, 324–327. [CrossRef] [PubMed]
23. Bischoff, W.E.; Reynolds, T.M.; Sessler, C.N.; Edmond, M.B.; Wenzel, R.P. Handwashing compliance by health care workers: The impact of introducing an accessible, alcohol-based hand antiseptic. *Arch. Intern. Med.* 2000, 160, 1017–1021. [CrossRef] [PubMed]



INNO  **SPACE**
SJIF Scientific Journal Impact Factor
Impact Factor: 8.379

doi[®]
CROSS **ref**

ISSN INTERNATIONAL
STANDARD
SERIAL
NUMBER
INDIA



INTERNATIONAL JOURNAL OF INNOVATIVE RESEARCH

IN COMPUTER & COMMUNICATION ENGINEERING

 **9940 572 462**  **6381 907 438**  **ijircce@gmail.com**



www.ijircce.com

Scan to save the contact details