



International Journal of Innovative Research in Computer and Communication Engineering

(A High Impact Factor, Monthly, Peer Reviewed Journal)

Website: www.ijircce.com

Vol. 5, Issue 10, October 2017

Energy Efficiency with Reconfigurable Data Architecture Line Based Dissemination

H.Lookman Sithic, P.Nandhini

Assistant Professor, Department of BCA, Muthayammal College of Arts & Science, Rasipuram, Namakkal Dt, India
Muthayammal College of Arts & Science, Rasipuram, Namakkal Dt, India

ABSTRACT: In wireless sensor networks (WSNs), energy efficiency is considered to be a crucial issue due to the limited battery capacity of the sensor nodes. Considering the usually random characteristics of the deployment and the number of nodes deployed in the environment, an intrinsic property of WSNs is that the network should be able to operate without human intervention for an adequately long time. In existing system various hierarchical approaches have been experimented, in which each approach suffers from overhead, hotspot and flooding problem. In this paper we propose ring routing approach energy-efficient mobile sink routing protocol is introduced, which aims to minimize this overhead while preserving the advantages of mobile sinks. The technique forms a ring of nodes from the available regular nodes. Ring is formed with the help of certain radius from the centre, nodes closer to the ring which is defined by the radius is formed. The location of the sink node is found through a ring node and is shared between all the ring nodes. Then the source node with the data forwards it to the sink through the anchor nodes. The proposed system achieves higher performance, lifetime and less delay while compared with the existing system.

KEYWORDS: Anchor Node, Wireless Sensor Networks, Hotspot, Flooding, Mobile sinks, Energy Efficiency.

I. INTRODUCTION

1.1 INTRODUCTION ABOUT WIRELESS SENSOR NETWORK

A Wireless sensor network is a group of specialized transducers with a communications infrastructure intended to monitor and record conditions at diverse locations. Commonly monitored parameters are temperature, humidity, pressure, wind direction and speed, illumination intensity, vibration intensity, sound intensity, power-line voltage, chemical concentrations, pollutant levels and vital body functions.

1.2 OVERVIEW

A sensor network consists of multiple detection stations called sensor nodes, each of which is small, lightweight and portable. Every sensor node is equipped with a transducer, microcomputer, transceiver and power source. The transducer generates electrical signals based on sensed physical effects and phenomena. The microcomputer processes and stores the sensor output. The power for each sensor node is derived from the electric utility or from a battery. The solutions to the problem is rectified by mobile sink [1],[6],[7],[10].

International Journal of Innovative Research in Computer and Communication Engineering

(A High Impact Factor, Monthly, Peer Reviewed Journal)

Website: www.ijircce.com

Vol. 5, Issue 10, October 2017

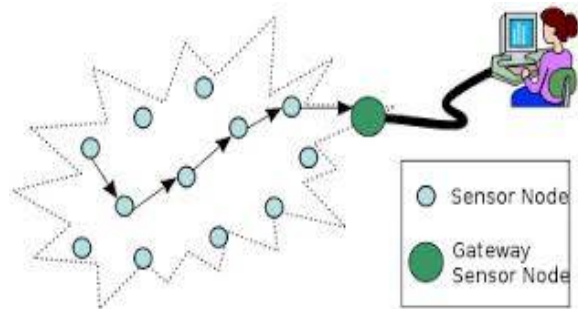

Figure 1.1 Sensor network

The WSN is built of "nodes" – from a few to several hundreds or even thousands, where each node is connected to one or several sensors. A sensor node might vary in size from that of a shoebox down to the size of a grain of dust, although functioning "motes" of genuine microscopic dimensions have yet to be created. The topology of the WSNs can vary from a simple star network to an advanced multi-hop wireless mesh network. Size and cost constraints on sensor nodes result in corresponding constraints on resources such as energy, memory, computational speed and communications bandwidth.

1.3.WSN CHARACTERISTICS AND ARCHITECTURE

A WSN is a homogenous or heterogeneous system consisting of hundreds or thousands of low cost and low-power tiny sensors to monitor and gather real-time information from deployment environment. Common functionalities of WSNs' nodes are broadcasting and multicasting, routing, forwarding and route maintenance. The sensor's components are: sensor unit, processing unit, storage unit, power supply unit and wireless radio transceiver; these units are communicating to each other.

Wireless communications and weak connections, Low reliability and failure capability in sensor nodes, Dynamic topology and self-organization, Hop-by-hop communications (multi-hop routing), Inter-nodes broadcast-nature communications.

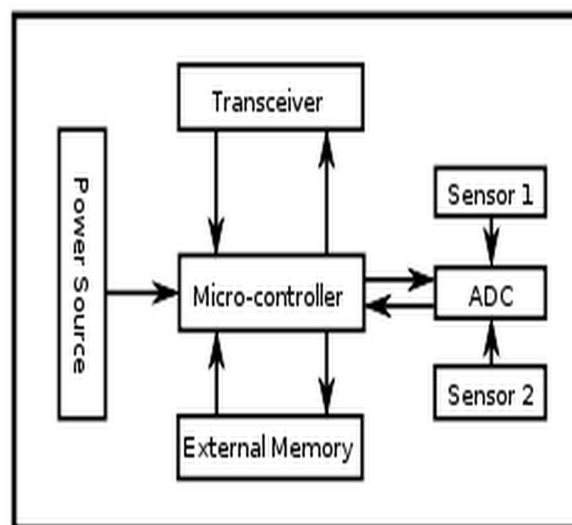

Figure 1.2 The typical architecture of the sensor node

International Journal of Innovative Research in Computer and Communication Engineering

(A High Impact Factor, Monthly, Peer Reviewed Journal)

Website: www.ijircce.com

Vol. 5, Issue 10, October 2017

The main components of a sensor node are a microcontroller, transceiver, external memory, power source and one or more sensors. The controller performs tasks, processes data and controls the functionality of other components in the sensor node. The functionality of both transmitter and receiver are combined into a single device known as a transceiver. The operational states are transmit, receive, idle, and sleep. Most transceivers operating in idle mode have a power consumption almost equal to the power consumed in receive mode. External memory used for storing application related or personal data, and program memory used for programming the device. An important aspect in the development of a wireless sensor node is ensuring that there is always adequate energy available to power the system. The sensor node consumes power for sensing, communicating and data processing. More energy is required for data communication than any other process. Sensors are hardware devices that produce a measurable response to a change in a physical condition like temperature or pressure. Sensors measure physical data of the parameter to be monitored. The continual analog signal produced by the sensors is digitized by an analog-to-digital converter and sent to controllers for further processing.

1.4 NEED FOR PROPOSED SYSTEM

Ring Routing establishes a virtual ring structure that allows the fresh sink position to be easily delivered to the ring and regular nodes to acquire the sink position from the ring with minimal overhead whenever needed. The ring structure can be easily changed. The ring nodes are able to switch roles with regular nodes by a straightforward and efficient mechanism, thus mitigating the hotspot problem. The wireless sensor network is battery operated. So the energy consumption is playing the major role. This work attempts to provide the fast delivery through quick accessibility and it can deal with increasing data rate successfully. Large sensor network can be managed efficiently as the multiple sink node reduces the energy consumption. Mobile sink can also be used for habitat monitoring, where a robot designated as the mobile sink gathers information from the sensors located in different areas of a large field [13].

II. EXISTING METHOD

In a typical wireless sensor network, the batteries of the nodes near the sink deplete quicker than other nodes due to the data traffic concentrating towards the sink, leaving it stranded and disrupting the sensor data reporting. To mitigate this problem, mobile sinks are proposed. The existing system introduced different routing protocol approaches with various drawback. The existing approaches are,

2.1(LBDD)-LINE BASED DATA DISSEMINATION

LBDD stands for line based data dissemination defines vertical strips of nodes centered on area of deployment. The information or data is first sent in to the line, the node which is first present in the line encounter the data. Sink node collects the data from the sensor nodes. In this LBDD straight forward mechanism is followed.

The drawback in this method are, It suffers from flooding problem which cause significant increase in overall energy consumption. In which flooding is the way to distribute routing information updates quickly to every node in a large network.

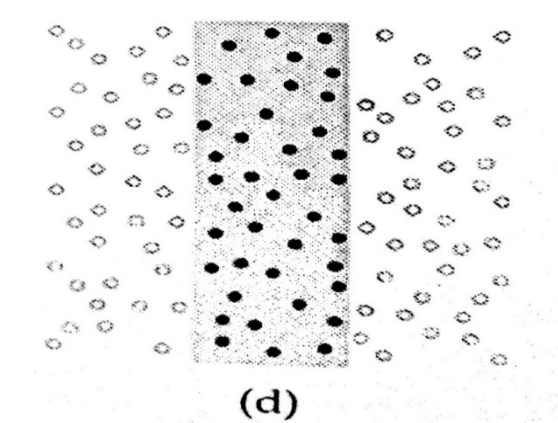

Fig 2.1 line approach

International Journal of Innovative Research in Computer and Communication Engineering

(A High Impact Factor, Monthly, Peer Reviewed Journal)

Website: www.ijircce.com

Vol. 5, Issue 10, October 2017

2.2 QUADTREE (QDD) APPROACH

QDD stands for Quad Tree based data dissemination protocol, by partitions of networks in to successive quadrants.

The quadrants are further divided in to smaller quadrants. The overhead that is present in the quadtree approach is minimum as compared to the other approaches.

The drawbacks present in this approach are, This method suffers from the hotspot problem, sensor nodes near to the base station are critical for the lifetime of sensor network because these nodes need to transmit more data than nodes away from base station. The structure of this approach is not flexible.

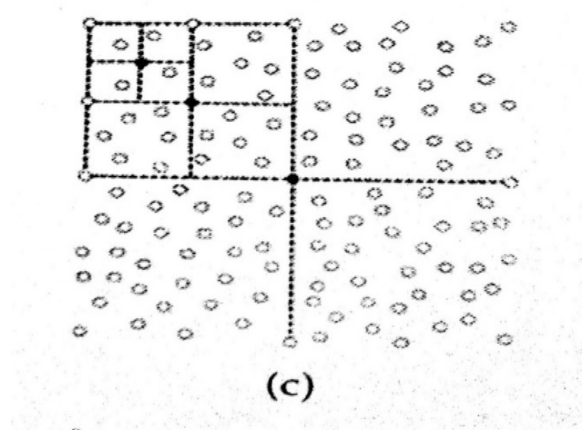

Fig 2.2 quadtree approach

2.3 RAIL ROAD APPROACH

Rail road constructs a structure called the rail, in which the strip of nodes are in closed loop. The nodes on the rail are called rail nodes. The sensor node data sends information to the node which is the nearest rail node. When the sink node is ready to collect data from the sensor nodes, that is when it comes nearer to the railroad all the sensor nodes will become active and results in wastage of energy.

The drawback in this approach it suffers from protocol overhead, resulting in delay and excess use of resources.

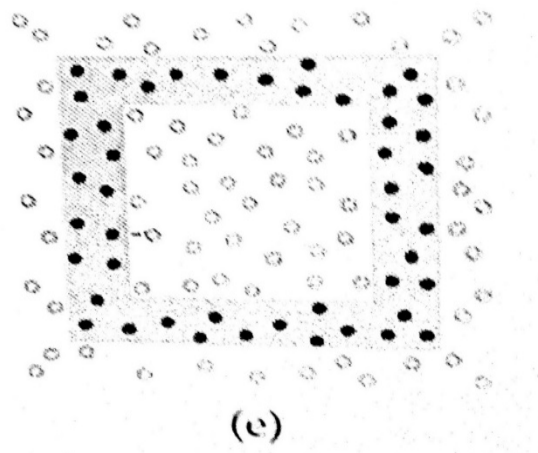

Fig 2.3 rail road approach

International Journal of Innovative Research in Computer and Communication Engineering

(A High Impact Factor, Monthly, Peer Reviewed Journal)

Website: www.ijircce.com

Vol. 5, Issue 10, October 2017

III. PROPOSED METHOD

Proposed system introduced a Ring Routing mechanism, a hierarchical routing protocol for wireless sensor networks with amobile sink. The protocol imposes three roles on sensornodes:(i) Ring nodes (ii) The Regular nodes (iii)anchor nodes. The three sensor roles are not fixed on its roles, meaning that sensor nodes can change their functions while operating in the wireless sensor network.The location of the sink node is found through a ring node and is shared between all the ring nodes. Then the source node with the data forwards it to the sink.

3.1 RING ROUTING WITH SINGLE MOBILE SINK

Ring routing it establishes a ring structure. The ring is formed with a certain radius from the centre node.It can able to form the ring structure with the node which has higher energy, ring can be easily changed.The ring consists of a node-width distance of one, strip of nodes that is closed are called the ring nodes. The shape of the ring may not be perfect as long as it forms a closed loop. After the deployment of the WSN, the ring is initially constructed by the following mechanism: An initial radius for the ring is determined.

The nodes nearer to the ring, that is defined by this radius and the center of network, by a certain threshold point are determined to be ring node candidates. From the starting of certain node (e.g. the node closest to the leftmost point on the ring) by geographic forwarding in a certain direction (clockwise/counter clockwise), the ring nodes are selected in a greedy manner until the starting node is reached and the closed loop is complete. If the starting node is not at a reachable distance, the procedure is repeated with selection of different neighbors at each hop. If after a certain number of trials the ring cannot be formed, the radius is set to a different value and the procedure above is repeated. The advantages of this approach are given

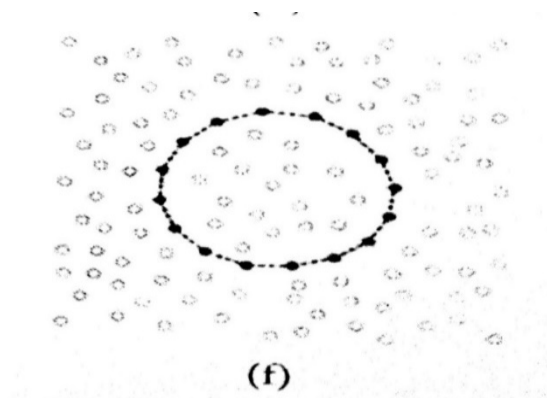

Fig 3.1 ring routing approach

- Protocol overhead is very low.
- Ring structure is flexible.
- Sink mobility pattern is random.

3.2 PROCEDURE FOR CREATING SINK POSITION ADVERTISEMENT

When the sink moves, it selects anchor nodes (ANs) with in its neighbors. The AN serves as a delegate managing the communications between the sink and the sensor nodes. As a first step, the sink chooses the closest node (e.g., the node with the greatest SNR value) as its anchor, and broadcasts an AN Selection (ANS) packet. Before the sink leaves the communication range of the AN, it selects a new anchor nodes and informs about the position of old anchor node and the MAC address of the new AN by another ANS packet. Since now the old AN knowsabout the new AN, it can relay

International Journal of Innovative Research in Computer and Communication Engineering

(A High Impact Factor, Monthly, Peer Reviewed Journal)

Website: www.ijircce.com

Vol. 5, Issue 10, October 2017

any data which is destined for it to the new AN. The current AN relays data packets directly to the sink. This mechanism is referred to as the follow-up mechanism. The AN selection and follow-up mechanisms are based on progressive footprint chaining [7]. Progressive AN selection provides a challenge in terms of finding out when and how a new AN should be selected, which is closely dependent on continuous link quality estimation. Although in ideal radio channel conditions, distance to the neighboring nodes, calculated via their geographic coordinates, may be indicative of the status of the link, it is rarely the case, not only the distance factor affects the radio link quality it can be affected by many factors. One of the more resilient methods of link quality estimation is beaconing. In this approach, the sink broadcasts periodically beacon messages, and a link quality estimation metric (e.g., RSSI) is calculated from the reply messages originating from the neighboring nodes. Depending on the value of this metric, the sink node takes decision whether to change the current AN and which node to select as the new AN. The period of the beacon messages should be tuned according to the mobility and speed of the sink, which are assumed to be known since the sink itself usually makes the mobility decisions.

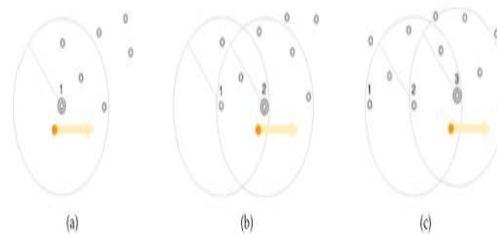

Anchor node (AN) selection: (a) time instance 1, AN: Node 1, (b) time instance 2, new AN: Node 2, and (c) time instance 3, new AN: Node 3.

Fig 3.2 advertisement of sink position

IV. ARCHITECTURE DIAGRAM

Starting from a certain node (e.g. the node closest to the leftmost point on the ring) by geographic forwarding in a certain direction (clockwise/counter clockwise), the ring nodes are selected in a greedy manner until the starting node is reached and the closed loop is complete. If the starting node cannot be reached, the procedure is repeated with selection of different neighbors at each hop. If after a certain number of trials the ring cannot be formed, the radius is set to a different value and the procedure above is repeated.



Fig 4.1 ring architecture

V. SOFTWARE SPECIFICATION

5.1 ABOUT NS-2

NS-2 is an open-source simulation tool running on Unix-like operating systems. It is a discreet event simulator targeted at networking research and provides substantial support for simulation of routing, multicast protocols and IP protocols, such as UDP, TCP, RTP and SRM over wired, wireless and satellite networks. It has many advantages that make it a useful tool, such as support for multiple protocols and the capability of graphically detailing network traffic. Additionally, NS-2 supports several algorithms in routing and queuing. LAN routing and broadcasts are part of routing algorithms. Queuing algorithm includes fair queuing, deficit round robin and FIFO.



International Journal of Innovative Research in Computer and Communication Engineering

(A High Impact Factor, Monthly, Peer Reviewed Journal)

Website: www.ijircce.com

Vol. 5, Issue 10, October 2017

NS-2 started as a variant of the REAL network simulator. REAL is a network simulator originally intended for studying the dynamic behavior of flow and congestion control schemes in packet-switched data networks. In 1995 ns development was supported by Defense Advanced Research Projects Agency DARPA through the VINT project at LBL, Xerox PARC, UCB, and USC/ISI.

5.2 PERFORMANCE EVALUATION

The performance comparison is done for various hierarchical approaches. Life time comparison is done for various nodes ($n=30$) for ring routing, LBDD, and rail road. Ring Routing slightly in most cases while Railroad has the worst performance for all cases. This behavior is due to the ANPI request/response mechanism employed by Ring Routing and Railroad. LBDD sends data packets directly to the line which relays them to the sink, thus eliminating the delay cost of waiting for the response to an ANPI request.

The delay comparisons for various nodes ($n=30$), is done for various approaches such as ring routing, rail road and LBDD approaches.

The total delay for data deliveries are broken down into two components. The ANPI request/response delay per data component is the time until a response to the ANPI request is received by a source node. The second component is the actual data dissemination delay of the path from the source to the sink.

The two components of Ring Routing's data delivery delays are compared with LBDD's average reporting delays. The delay cost of the request/ response mechanism is apparent. The actual data dissemination delays of Ring Routing is lower than LBDD's reporting delays.

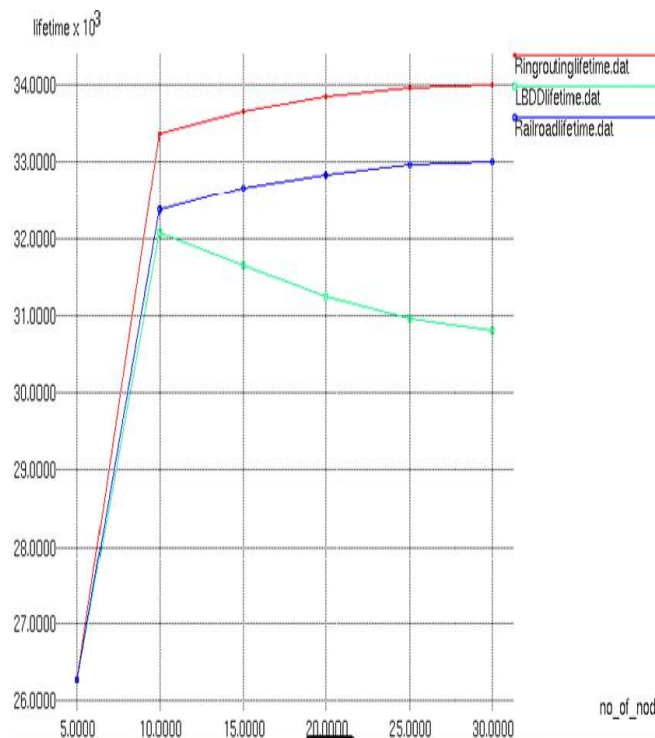

Fig 5.1 life time comparisons for various methods ($n=30$) nodes

International Journal of Innovative Research in Computer and Communication Engineering

(A High Impact Factor, Monthly, Peer Reviewed Journal)

Website: www.ijircce.com

Vol. 5, Issue 10, October 2017

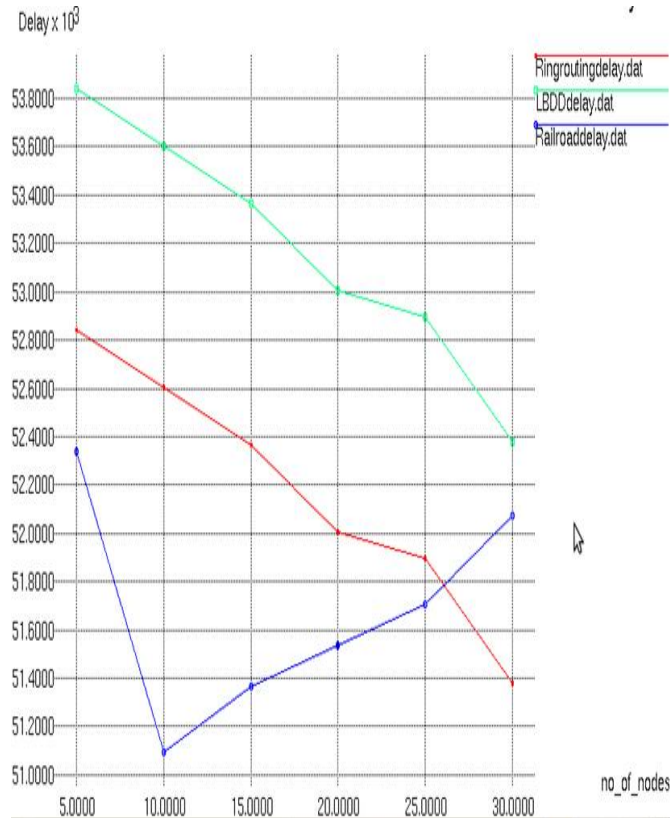

Fig 5.2 delay comparisons for various methods (n=30) nodes

VI.CONCLUSION

A novel mobile sink routing protocol is proposed Ring Routing, by both considering the benefits and the drawbacks of the existing protocols in the literature. Ring Routing is an hierarchical routing protocol based on a virtual ring structure which is designed to be easily accessible and easily reconfigurable. The design requirement of our protocol is to mitigate the anticipated hotspot problem observed in the hierarchical routing approaches and minimize the data reporting delays considering the various mobility parameters of the mobile sink. The performance of Ring Routing is evaluated extensively by simulations conducted in the network simulation environment. A wide range of different scenario with varying network sizes and sink speed values are defined and used. Comparative performance evaluation results of Ring Routing with two efficient mobile sink protocols, LBDD and Railroad, which are also implemented in NS 2, are provided. The results show that Ring Routing indeed is an energy-efficient protocol which extends the network lifetime. The reporting delays are confined within reasonable limits which proves that Ring Routing is suitable for time sensitive applications.

In the future, we can modify Ring Routing to support multiple mobile sinks, and clustering approach is used for large wireless sensor network to mitigate traffic and congestion problem.

REFERENCES

- [1] M. Buettner, G. V. Yee, E. Anderson, and R. Han, "X-MAC: A short preamble mac protocol for duty-cycled wireless sensor networks," in Proc. 4th Inter. Conf. Embedded Network Sensor Syst., ser. SenSys '06. New York, NY, USA: ACM, 2006, pp. 307–320.
- [2] I. Chatzigiannakis, A. Kinalis, and S. Nikolettseas, "Efficient data propagation strategies in wireless sensor networks using a single mobile sink," Comput. Commun., vol. 31, no. 5, pp. 896–914, 2008.



International Journal of Innovative Research in Computer and Communication Engineering

(A High Impact Factor, Monthly, Peer Reviewed Journal)

Website: www.ijirccce.com

Vol. 5, Issue 10, October 2017

- [3] Can Tunca, SinanIsik, Mehmet YunusDonmez, and CemErsoy, "Ring Routing: An Energy-Efficient Routing Protocol for Wireless Sensor Networks with a Mobile Sink," IEEE transactions on mobile computing, vol. 14, no. 9, september 2015.
- [4] M. Di Francesco, S. K. Das, and G. Anastasi, "Data collection in wireless sensor networks with mobile elements: A survey," ACM Trans. Sens. Netw., vol. 8, no. 1, pp. 1–31, 2011.
- [5] D. K. Goldenberg, J. Lin, A. S. Morse, B. E. Rosen, and Y. R. Yang, "Towards mobility as a network control primitive," in Proc. 5th ACM Int. Symp. Mobile ad hoc Networ. comp., ser. MobiHoc '04. New York, NY, USA: ACM, 2004, pp. 163–174.
- [6] A. Gopakumar and L. Jacob, "Localization in wireless sensor networks using particle swarm optimization," in Proc. IET Int. Conf. Wireless, Mobile Multimedia Netw., 2008, pp. 227–230.
- [7] R. Jaichandran, A. Irudhayaraj, and J. Raja, "Effective strategies and optimal solutions for hot spot problem in wireless sensor networks (WSN)," in Proc. 10th Int. Conf. Inf. Sci. Signal Process. Appl., 2010, pp. 389–392.
- [8] I. Kang and R. Poovendran, "Maximizing static network lifetime of wireless broadcast ad hoc networks," in Proc. IEEE int. Conf. Commun., vol. 3, 2003, pp. 2256–2261.
- [9] W. Liang, J. Luo, and X. Xu, "Prolonging network lifetime via a controlled mobile sink in wireless sensor networks," in Proc. IEEE Global Telecommun. Conf., 2010, pp. 1–6.
- [10] K. Lin, M. Chen, S. Zeadally, and J. J. Rodrigues, "Balancing energy consumption with mobile agents in wireless sensor networks," Future Generation Comput. Syst., vol. 28, no. 2, pp. 446–456, 2012.
- [11] C.-J. Lin, P.-L. Chou, and C.-F. Chou, "HCDD: Hierarchical cluster-based data dissemination in wireless sensor networks with mobile sink," in Proc. Int. Conf. Wireless Commun. Mobile Comput., 2006, pp. 1189–1194.
- [12] X. Li, J. Yang, A. Nayak, and I. Stojmenovic, "Localized geographic routing to a mobile sink with guaranteed delivery in sensor networks," IEEE J. Sel. Areas Commun., vol. 30, no. 9, pp. 1719–1729, Sep. 2012.
- [13] J. Luo and J.-P. Hubaux, "Joint mobility and routing for lifetime elongation in wireless sensor networks," in Proc. INFOCOM 24th Annu. Joint Conf. IEEE Comput. Commun. Soc., vol. 3, 2005, pp. 1735–1746.
- [14] D. Moss, and P. Levis, "BoX-MACs: Exploiting physical and link layer boundaries in low-power networking," Stanford Univ., Stanford, CA, USA, Tech. Rep. SING-08-00, 2008.
- [15] D. Niculescu, "Positioning in ad hoc sensor networks," IEEE Netw., vol. 18, no. 4, pp. 24–29, Jul. 2004.
- [16] S. Oh, Y. Yim, J. Lee, H. Park, and S.-H. Kim, "Non-geographical shortest path data dissemination for mobile sinks in wireless sensor networks," in Proc. IEEE Veh. Technol. Conf., Sep. 2011, pp. 1–5.
- [17] S. Olariu and I. Stojmenovi, "Design guidelines for maximizing lifetime and avoiding energy holes in sensor networks with uniform distribution and uniform reporting," in Proc. IEEE INFOCOM, 2006, pp. 1–12.
- [18] J. Rao and S. Biswas, "Network-assisted sink navigation for distributed data gathering: Stability and delay-energy trade-off," Comput. Commun., vol. 33, no. 2, pp. 160–175, 2010.
- [19] Z. Wang, S. Basagni, E. Melachrinoudis, and C. Petrioli, "Exploiting sink mobility for maximizing sensor networks lifetime," in Proc. 38th Annu. Hawaii Int. Conf. Syst. Sci., 2005, p. 287.
- [20] Y. Yun and Y. Xia, "Maximizing the lifetime of wireless sensor networks with mobile sink in delay-tolerant applications," IEEE Trans. Mobile Comput., vol. 9, no. 9, pp. 1308–1318, Jul. 2010.