



IJIRCCCE

e-ISSN: 2320-9801 | p-ISSN: 2320-9798



INTERNATIONAL JOURNAL OF INNOVATIVE RESEARCH

IN COMPUTER & COMMUNICATION ENGINEERING

Volume 12, Issue 1, January 2024

ISSN INTERNATIONAL
STANDARD
SERIAL
NUMBER
INDIA

Impact Factor: 8.379

 9940 572 462

 6381 907 438

 ijircce@gmail.com

 www.ijircce.com

Optimization of PAPR Reduction for MIMO System using DCT and DWT Technique

Farhan Ansari¹, Anand Singh Rajput², Ashish Pournanike³

M. Tech. Scholar, Department of Electronics and Communication Engineering, All Saints College of Technology, Bhopal, India¹

Assistant Professor, Department of Electronics and Communication Engineering, All Saints College of Technology, Bhopal, India²

Head of Dept., Department of Electronics and Communication Engineering, All Saints College of Technology, Bhopal, India³

Abstract: Orthogonal frequency division multiplexing (OFDM) is one of such popular method for achieving this high information rate. OFDM has several advantages, but one of the main drawbacks is its high peak-to-average power ratio (PAPR). However, the challenging part is that most of the PAPR reduction schemes come with high computational complexity. Recent PAPR reduction techniques such as partial transmit sequence (PTS) has been considered as most popular for PAPR reduction. This research work explores to find a solution for the PAPR reduction by using PTS technique, which has been implemented by using sub-blocks partitioning. In sub-block partition consists of OFDM data frame which is partitioned into several sub-blocks. An adjacent partitioning (AP) method can be perceived as the best of the existing partitioning method when the cost and PAPR reduction performance are considered together. In this paper a new partial transmit sequence (PTS) technique, based on PTS with discrete cosine transform (DCT) and discrete wavelet transform (DWT), for 32 antennas MIMO-OFDM system, is proposed which can achieve better PAPR performance at much less bit error rate (BER). Simulation results show that the proposed approach can reduce BER and achieve a better PAPR reduction compared to previous PTS technique.

KEYWORDS: PTS, DCT, MIMO-OFDM, PAPR, BER

I. INTRODUCTION

The present mobile multimedia networks such as 4G networks have different Quality of Service (QoS) requirements for diverse applications starting from voice to Multi Media Services (MMS) with major objectives such as better modulation control schemes, effective bandwidth utilization, support for real-time and non-real time content transfer and mobility. So the network aims to satisfy their demands without much degradation of quality. Orthogonal Frequency Division Multiplexing (OFDM) is the modulation technique used in many new broadband communication schemes including digital television, digital audio, Asymmetric Digital Subscriber Line (ADSL) and wireless LANs (HIPERLAN 2, IEEE 802.11a). Due to its efficient use of transmission bandwidth and tolerance of multipath impairments, OFDM is also being considered for many other wireless communication systems including 4G wireless. Many recent multimedia communication systems use OFDM and its band is subdivided into many smaller narrow-band channels. In OFDM, the maximum amplitude of the time domain signal is very large. It results in the amplification to move into the non-linear region. It creates various problems that reduce the performance of the whole system. Hence, the performance analysis plays a key role in the resource management of the OFDM system. The need for proposed work is:

- i) In OFDM, with respect to Peak-to-Average-Power-Ratio (PAPR) problem is to reduce the operating point of the amplifier with a back-off margin. This margin is chosen and it avoids most of the occurrences of high peaks falling in the nonlinear region of the amplifier.
- ii) PAPR reduction is a significant signal processing technique in multi-carrier transmission and a large number of techniques have been proposed in the literature. Simulation techniques have been proposed, analyzed, compared and better performance results have been obtained.

The present implementations of OFDM do not fully utilize the capabilities of OFDM. Many areas can be explored to minimize the Peak-to Average Power Ratio (PAPR) of OFDM signal. The PAPR performance of existing schemes is either unique or poor than normal OFDM signal. The necessity to reduce the PAPR of normal OFDM signal and OFDM signal obtained from conventional schemes has been a prime motivating factor for this research work. The thesis aims at exploring and arriving at the schemes for PAPR reduction in OFDM based systems of practical interest in an effective and efficient way.

II. MIMO-OFDM SYSTEM

MIMO in combination with OFDM is widely used nowadays due its best performance in terms of capacity of channels, high data rate and good outcome in frequency selective fading channels [7]. In addition to this it also improves reliability of link. This is attained as the OFDM can transform frequency selective MIMO channel to frequency flat MIMO channels [8]. So it is widely used in future broadband wireless system/communications. Cyclic prefix is the copy of last part of OFDM symbol which is appended to the OFDM symbol that is to be transmitted. It is basically 0.25% of the OFDM symbol. We can say that one fourth of the OFDM symbol is taken as CP (cyclic prefix) and appended to each OFDM symbol. IFFT is used at the transmitter and FFT is used at the receiver which substitutes the modulators and demodulators. Doing so eliminates the use of banks of oscillators and coherent demodulators. Moreover the complex data cannot be transmitted as it is; therefore it is first converted to analog form which is accomplished by IFFT. It basically converts the signal from frequency domain to time domain. Prior to IFFT operation symbol mapping is performed which is nothing but the modulation block. Any of the widely used modulation techniques can be applied like BPSK, QPSK, QAM, PSK etc. Further there are higher order modulations are also available which provide more capacity at little expense of BER performance degradation [9]. After IFFT block pilot insertion is done and then CP (cyclic prefix) is added. Figure 1 below shows the block diagram constituting MIMO and OFDM. Any antenna configuration for the MIMO can be used according to the system requirement. Higher the configuration more will be the capacity and more will be the computational complexity of the transceiver design. It is seen that in the case of estimating channel the computational complexity is increased. Mapper defines the modulation to be used. Symbol encoder takes the shape of the STBC (Space Time Block Code) if spatial diversity is to be used and it takes the shape of the de-multiplexer/multiplexer if spatial multiplexing is to be used.

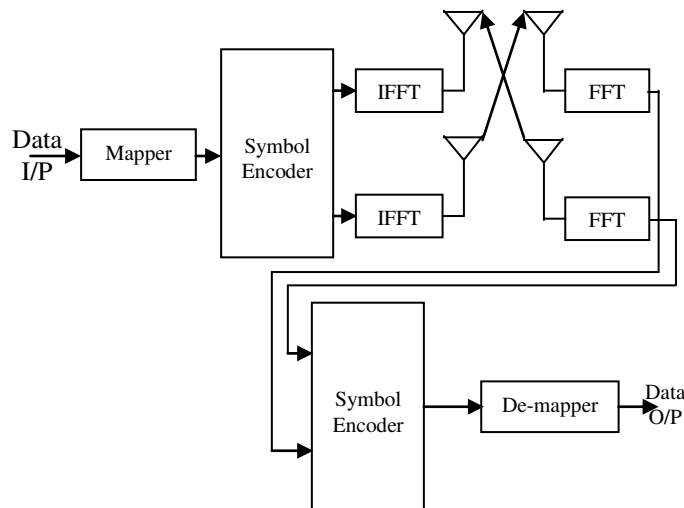

Figure 1: MIMO-OFDM system model

The received signal at j^{th} antenna can be expressed as

$$R_j[n,k] = \sum H_{ij}[n,k] X_i[n,k] + W[n,k] \quad (1)$$

Where H is the channel matrix, X is the input signal and W is noise with zero mean and variance. Also $b_i[n,k]$ represents the data block i^{th} transmit antenna, n^{th} time slot and k^{th} sub channel index of OFDM. Here i and j denoted the transmitting antennas index and receiving antenna index respectively.

The MIMO-OFDM system model [10] with N_R receives antennas and N_T transmits antennas can be given as

$$\begin{bmatrix} Z_1 \\ Z_2 \\ \vdots \\ Z_N \end{bmatrix} = \begin{bmatrix} H_{1,1} & H_{1,2} & \dots & H_{1,NT} \\ H_{2,1} & H_{2,2} & \dots & H_{2,NT} \\ \vdots & \vdots & \ddots & \vdots \\ H_{NR,1} & H_{NR,2} & \dots & H_{NR,NT} \end{bmatrix} \begin{bmatrix} A_1 \\ A_2 \\ \vdots \\ A_{NT} \end{bmatrix} + \begin{bmatrix} M_1 \\ M_2 \\ \vdots \\ M_{NT} \end{bmatrix} \tag{2}$$

Where, Z represents O/P data vector, H denotes Channel matrix, A denotes I/P data vector and M represents Noise vector. The wireless channel used is AWGN channel. After receiving the signal the CP is removed then the pilots are also removed from main signal received. After this the signal that is in time domain can be again converted to frequency domain by taking FFT of the received signal.

The sequence on each of the OFDM block is then provided to channel estimation block where the received pilots altered by channel are compared with the original sent pilots. Channel estimation block consists of the algorithms that are applied to estimate the channel.

III. PTS SCHEMES

In the SISO-PTS scheme, the original data sequence in the frequency domain is partitioned into M disjoint, equal length sub blocks X_v ($v = 1, 2, \dots, M$) as follows [11].

$$X = \sum_{v=1}^M X_v \tag{3}$$

By multiplying some weighting coefficients to all the subcarriers in every subblock, we can get the new frequency sequence.

$$X' = \sum_{v=1}^M b_v X_v \tag{4}$$

Finally, at each transmitting antenna, there are (V-1) sub blocks to be optimized, and the candidate sequence with the lowest PAPR is individually selected for transmitting. Assume that there are W allowed phase weighting factors. To achieve the optimal weighting factors for each transmitting antenna, combinations should be checked in order to obtain the minimum PAPR [12].

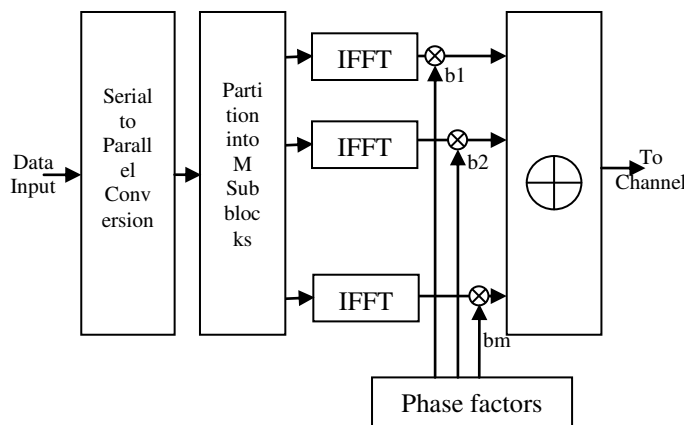

Figure 2: Block Diagram of PTS Scheme

In, the idea of alternate optimization is introduced, and it can be also applied to PTS in multiple antennas OFDM systems, denoted as alternate PTS. Different from ordinary PTS, phase weighting factors are needed only for half of the sub blocks in A-PTS. That is to say, starting from the first sub block, every alternate sub block is kept unchanged and phase weighting factors are optimized only for the rest of the sub blocks, which leads to the reduction of computational complexity. In this way, the computational complexity is greatly reduced at the expense of PAPR performance degradation [11]. Employed spatial sub block circular permutation for A-PTS scheme to increase the number of candidate sequences which improves the PAPR performance further.

Next, the conversion of the optimum weighting coefficient is discussed. In order to maintain the conjugate and symmetric relations between the two antennas after scrambling sequence methods, we should convert the optimum

weighting coefficient $a(\text{opt})$ at antenna 1 into that of antenna 2 denoted as $b(\text{opt})$ by the inverse conjugate and symmetric transformation. For example, when the optimum weighting coefficient $a(\text{opt})$ is $[1, 1, j, -j]$, the optimum weighting coefficient for antennas 2 is $b(\text{opt}) = [1, 1, -j, j]$. The PTS scheme can be also applied to the MIMO-OFDM system with more transmits antennas.

Based on advance PTS, an approach to solve the contradiction between the PAPR performance and computational complexity in STBC MIMO-OFDM system is proposed. Let us consider a STBC MIMO-OFDM system that employs Alamouti scheme. The coding matrix is:

$$G = \begin{pmatrix} x_1 & -x_2^* \\ x_2 & x_1^* \end{pmatrix} \tag{5}$$

Simulation experiments are conducted to evaluate the transmit spectrum, bit error rate (BER), peak average to peak ratio (PAPR) reduction performance of the MIMO-OFDM scheme using PTS technique. In addition, it is assumed that the data are QPSK, 16-QAM modulated and are transmitted using 256 FFT.

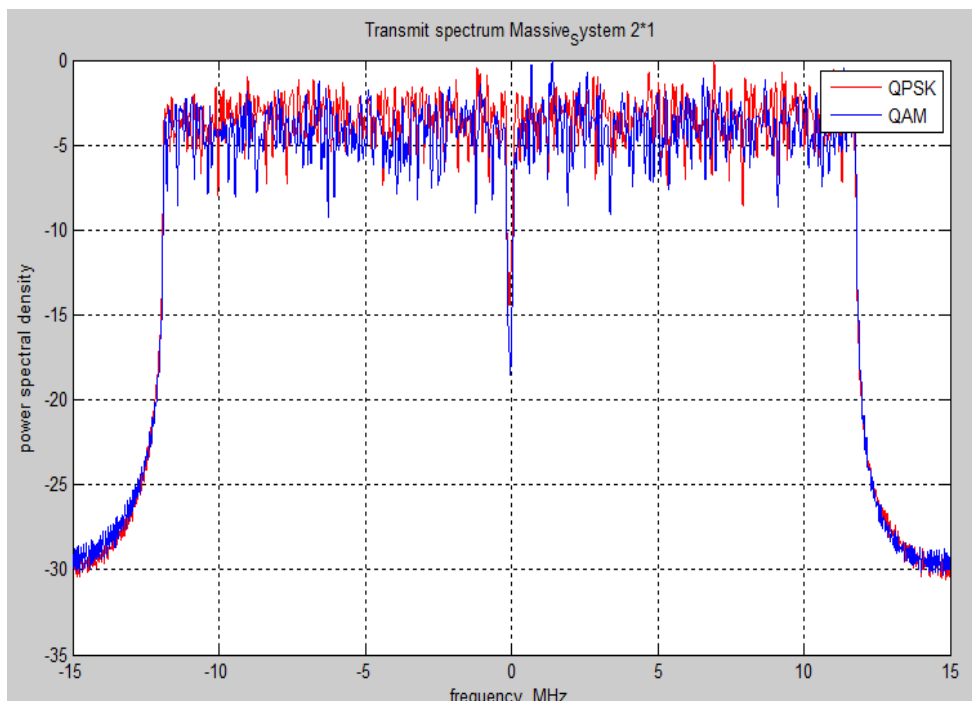

Figure 3: Power Spectral Density of MIMO 2x1 System

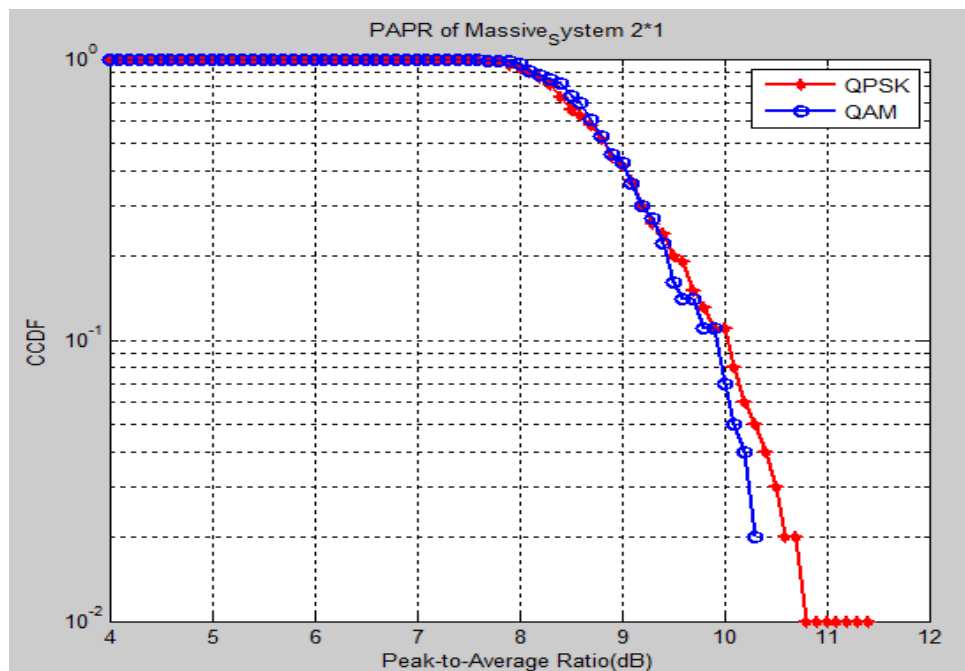

Figure 4: PAPR Performance of MIMO 2x1 System

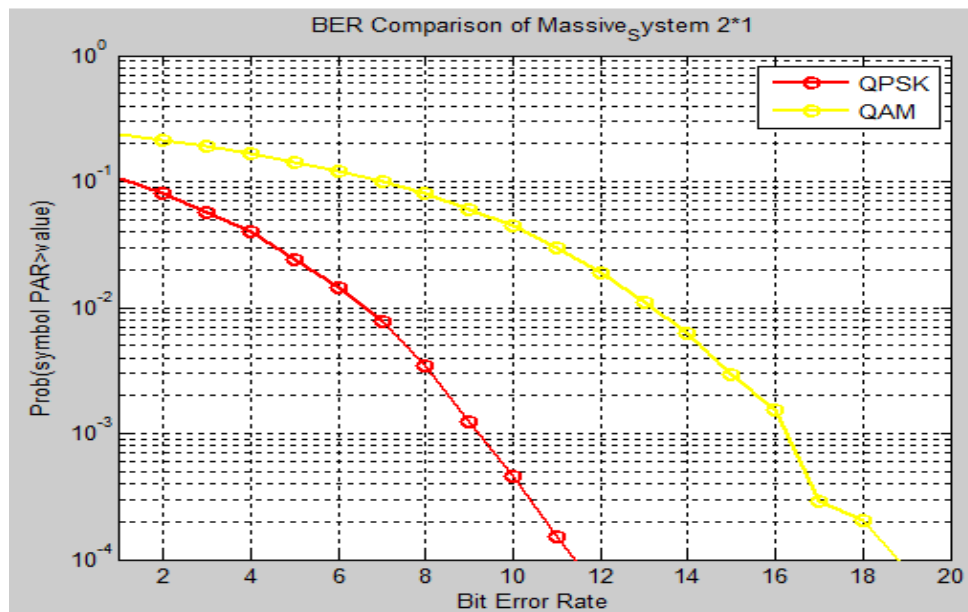

Figure 5: BER Performance of MIMO 2x1 System

IV. PROPOSED METHODOLOGY

We have proposed a wavelet based MIMO-OFDM system for the reduction of PAPR, which effectively reduces the PAPR on rational selection of phase values. First the original input signal is modulated with BPSK, QPSK, QAM-16 and PTS technique had been applied, where the phase values are generated using optimized algorithm. This helps to minimize the PAPR of the input signal. Then discrete wavelet transform is applied and has been followed by DCT and DWT which is applied transmitted through AWGN channel. At the receiver, the inversion of transmitter will be done.

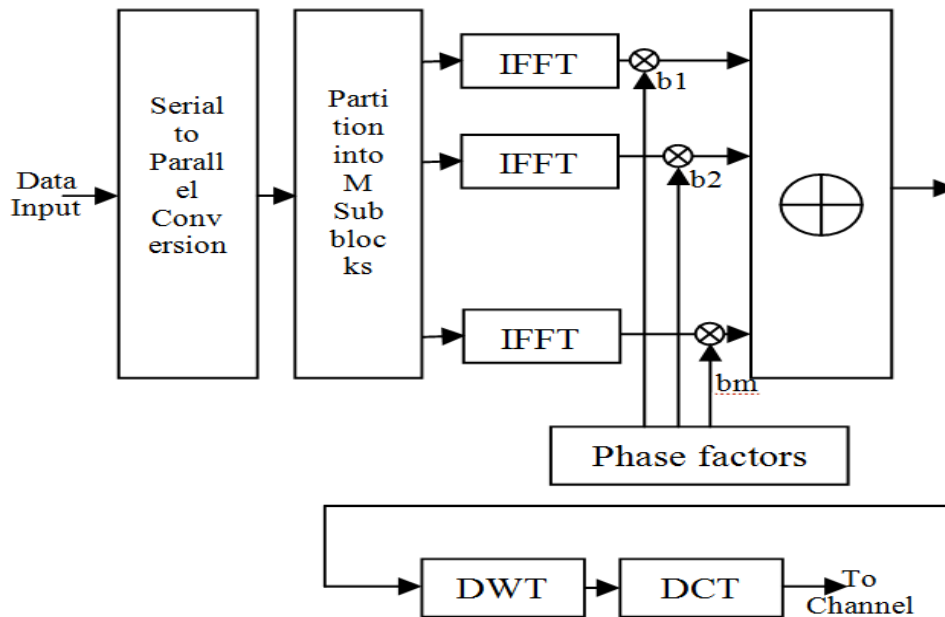

Figure 6: Flow Char of Proposed Methodology

Figure 6 shows the enhanced transmitter block diagram of the presented work. In this research work conventional OFDM is followed by the DCT for PAPR reduction and vice versa is also simulated. Both transmitter and receiver are simulated in order to calculate the BER.

V. SIMULATION RESULT

The CCDF is generally used to evaluate the performance of PAPR reduction on MIMO-OFDM system (IEEE 802.16e) signals for a statistical pair of view. The CCDF is defined as the probability that the PAPR as in equation and $PAPR_0$ as shown in the following:

$$PAPR\{Y\} = \arg \max_{k=1,2,3,\dots,N_T} (PAPR\{Y_k\})$$

Where Y_k , $k = 1.2.3.\dots.N_T$ represents the time-domain transmitted signal of the k-th antenna

$$CCDF(PAPR_0) = \Pr(PAPR\{Y\} > \{PAPR_0\})$$

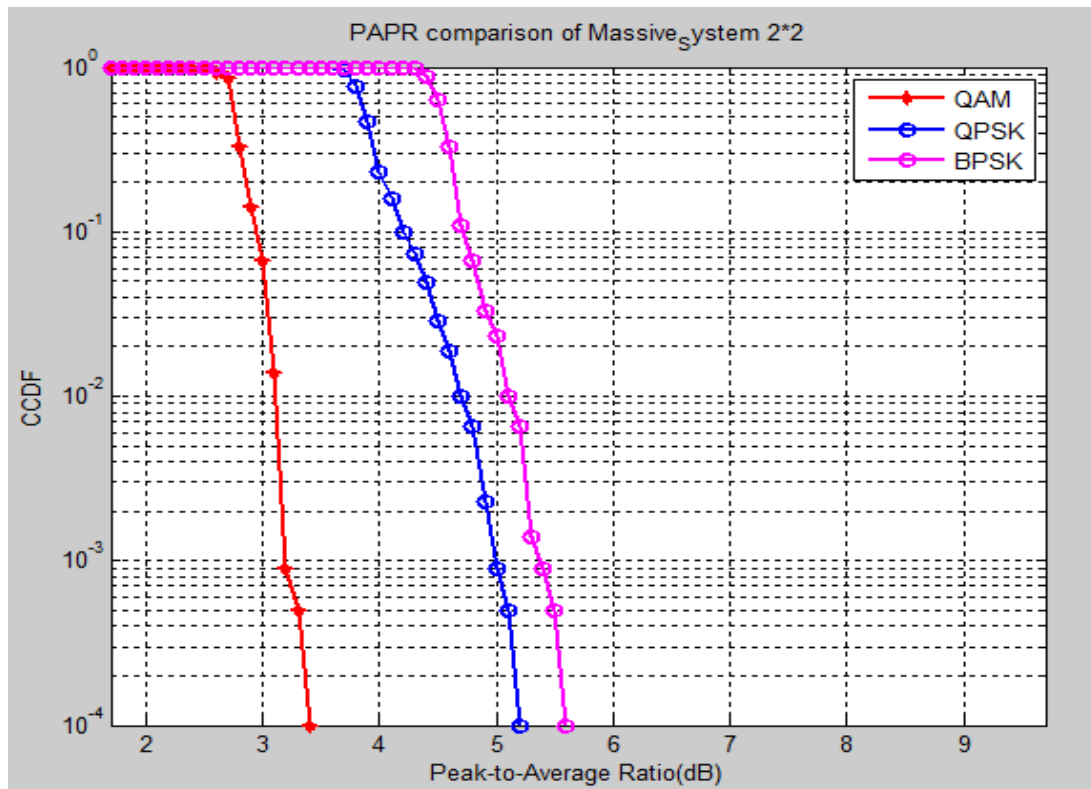

Figure 7: PAPR of Massive 2x2 System with Companding and DCT technique

Figure 7 represents the PAPR of 22x22 Massive system using DWT and DCT technique with the help of QAM-16, QAM-32 and QAM-64. QAM -64 provide best PAPR compared to QAM-16. Zhitong Xing et al. [1] is providing PAPR 3.9 dB for companding schemes 4.3 dB for HCC, FHCC and MHCC schemes. Ebubekir Memisoglu et al. [2] is providing 10.8 dB for numerology =1, 9.9 dB for numerology <1 and 10.9 dB for numerology >1. The proposed scheme is provide PAPR 3.4 dB for QAM-64, 5.2 dB for QAM-32 and 5.5 dB for QAM-16. Clearly that, the proposed schemes is 65.65% improvement compared to Ebubekir Memisoglu et al. [2] and 29.41% improvement compared to Zhitong Xing et al. [1].

VI. CONCLUSION

MIMO-OFDM is a very agreeing method for the new wireless digital communication system. Along with the simplicity of equalization in Orthogonal Frequency Division Multiplexing (OFDM) modulation, it combines the capacity and diversity gain of MIMO systems for better performance. However, like conventional OFDM, MIMO-OFDM has a major challenge called high PAPR. Hence, it requires high dynamic range power amplifier, which makes more cost of system and decreases the efficiency of power. In this paper, a method is proposed for minimization of PAPR in MIMO-OFDM systems using PTS method. The PTS is concatenated with DCT and DWT signal processing algorithm to improve the efficiency and reduction of peak power of the MIMO-OFDM system. Because of autocorrelation of DCT the average power will be reduced. By using PTS method, the optimum phase's factors are selected to reduce the average power. Hence it is achieved that MIMO- OFDM signals with less PAPR.

REFERENCES

1. Zhitong Xing, Kaiming Liu, Aditya S. Rajasekaran, Halim Yanikomeroglu and Yuanan Liu, "A Hybrid Companding and Clipping Scheme for PAPR Reduction in OFDM Systems", IEEE Access 2021.
2. H. Chen, J. Hua, J. Wen, K. Zhou, J. Li, D. Wang, and X. You, "Uplink interference analysis of F-OFDM systems under non-ideal synchronization," IEEE Trans. Veh. Technol., vol. 69, no. 12, pp. 15500–15517, Dec. 2020.
3. S. Rajasekaran, M. Vameghestahbanati, M. Farsi, H. Yanikomeroglu, and H. Saeedi, "Resource allocation-based PAPR analysis in uplink SCMA-OFDM systems," IEEE Access, vol. 7, pp. 162803–162817, 2019.
4. Z. Zhou, L. Wang, and C. Hu, "Low-complexity PTS scheme for improving PAPR performance of OFDM systems," IEEE Access, vol. 7, pp. 131986–131994, 2019.

5. W. Hu, "SLM-based ACO-OFDM VLC system with low-complexity minimum amplitude difference decoder," *Electron. Lett.*, vol. 54, no. 3, pp. 141–146, 2018.
6. Y. Hori and H. Ochiai, "A new uplink multiple access based on OFDM with low PAPR, low latency, and high reliability," *IEEE Trans. Commun.*, vol. 66, no. 5, pp. 1996–2008, May 2018.
7. Ashna Kakkar, Sai Nitesh Garsha, Ojasvi Jain and Kritika, "Improvisation in BER and PAPR by using hybrid reduction techniques in MIMO-OFDM employing channel estimation techniques", 7th International Advance Computing Conference, IEEE 2017.
8. Ho-Lung Hung, Yung-Fa Huang, Ching-Chuan and Rung-Ching Chen, "Performance of PTS-Based Firefly Algorithm Scheme for PAPR Reduction in SFBC MIMO-OFDM Communication Systems", *International Symposium on Computer, Consumer and Control*, IEEE 2016.
9. P. Kothai and R. Prabhu M.E., "PAPR Reduction in MIMO OFDM Using Adaptive SLM Scheme", *International Journal for Research in Applied Science & Engineering Technology (IJRASET)*, Vol. 03, No. 05, pp. 729-735, May 2015.
10. Muhammet Nuri Seyman, Necmi Taspmar, "Channel estimation based on neural network in space time block coded MIMO-OFDM system", *Digital Signal Processing*, Vol. 23, No.1, pp. 275-280, Jan. 2013.
11. P. Mukunthan and, P Dananjayan, " PAPR Reduction based on a Modified PTS with Interleaving and Pulse Shaping method for STBC MIMO-OFDM System", *IEEE ICCCNT'12* , 26th _28th July 2012, Coimbatore, India.
12. L. Yang, K. K. Soo, S. li, and Y. M. SU, "PAPR Reduction Using Low Complexity PTS to Construct of OFDM Signals Without Side Information", *IEEE Transactions on Broadcasting*, Vol. 57, No. 2, pp. 4532-4539, June 2011.
13. Anushree Neogi and Abhijit Mitra "MAP Estimation of CFO and STO for a Convolutionally Coded OFDM System" *National Conference on Communications (NCC)*, pp. 01-05, IEEE 2011.
14. Chin-Liang Wang and Shun-Sheng Wang and Hsiao-Ling Chang, "A Low-Complexity SLM Based PAPR Reduction Scheme for SFBC MIMO-OFDM Systems", 978-1-61284-254-7/11 IEEE 2011.
15. Li, M., Wang, X. and Guo, L.W. "The Research on the Performance of Iterative KALMAN Channel Estimation in MIMO-OFDM System", *Journal of Hebei University of Science and Technology*, Vol. 31, No.6, pp. 550-552, Dec. 2010.



INNO  **SPACE**
SJIF Scientific Journal Impact Factor
Impact Factor: 8.379

doi[®]
CROSS **ref**

ISSN INTERNATIONAL
STANDARD
SERIAL
NUMBER
INDIA



INTERNATIONAL JOURNAL OF INNOVATIVE RESEARCH

IN COMPUTER & COMMUNICATION ENGINEERING

 **9940 572 462**  **6381 907 438**  **ijircce@gmail.com**



www.ijircce.com

Scan to save the contact details