



Implementation of Fuzzy Logic for Concurrency Control in Cad

Muthu Kumaravel .A^{*1}, Purushothaman .S², Rajeswari .S³

¹HOD, Dept. of MCA, Bharath University, Chennai, Tamil Nadu, India

²Associate Professor, Institute of Technology, Haramaya University, Dire Dawa, Ethiopia,

³Assistant Professor, Dept. of EEE, Institute of Technology, Haramaya University, Dire Dawa,

*Corresponding Author

ABSTRACT: This research work focuses on implementation of Fuzzy Logic for Concurrency Control methods using Fuzzy Logic with applications to Computer Aided Design / Computer Aided Manufacturing (CAD/CAM) database that involves more and unspecified duration of time to complete a transaction. Most of the transactions in the CAD/CAM data base include drawing entities to form a complete manufacturing drawing, with processing and inventory details. In this research work, Fuzzy Logic for implementing Concurrency Control while developing product Bearing using Autodesk inventor 9. While implementing concurrency control, this work ensures that associated parts cannot be accessed by more than one person due to locking. The Fuzzy Logic learn the objects and the type of transactions to be done based on which node in the output layer of the network exceeds a threshold value.

KEYWORDS: Concurrency Control, Fuzzy Logic, Bearing, Transaction Locks, CAD Database. *Time Stamping.*

1. INTRODUCTION

Concurrency Control (CC) is an important concept for proper transactions on objects to avoid any loss of data or to ensure proper updating of data in the database, Christos (1982). It is an important aspect in controlling and coordinating data reading and data modification especially in long time transaction database. In spite of sophisticated algorithms available for proper locking, Kyung et al. (1981), Eswaran et al. (1976), and unlocking of objects during transactions, intelligent methods with knowledgebase information have been proposed and implemented in this research work.

This research work focuses on implementation of novel concurrency control methods using Fuzzy Logic with applications to Computer Aided Design / Computer Aided Manufacturing (CAD/CAM) database that involves more and unspecified duration of time to complete a transaction, Lee et al. (1983). Most of the transactions in the CAD/CAM data base include drawing entities to form a complete manufacturing drawing, with processing and inventory details. In this research work, focus is given on drawing entities by many designers. The transaction follows schema used to develop the CAD/CAM database for drawing. The schema generally is based on Standards for the Exchange of Product model data (STEP) format. STEP is the colloquial term for the International organization for standardization (ISO) 10303 Industrial systems and integration–Product data representation and exchange.

The model supports five lock modes on a version of an object:

- (1) read-only, which makes a version available only for reading.
- (2) Read / derive, which allows multiple users to either read the same version or derive a new version from it;
- (3) shared derivation, which allows the owner to both read the version and derive a new version from it, while allowing parallel reads of the same version and derivation of different new versions by other users;
- (4) Exclusive derivation, which allows the owner of the lock to read a version of an object and derive a new version, and allows only parallel reads of the original version; and
- (5) Exclusive lock, which allows the owner to read, modify and derive a version, and allows no parallel operations on the locked version.

International Journal of Innovative Research in Computer and Communication Engineering

(An ISO 3297: 2007 Certified Organization)

Vol. 2, Issue 11, November 2014

II. PROBLEM DEFINITION

This Research work discusses the components that have been considered for implementing concurrency control during transaction of objects [1]. Figure 1 (Bearing) give the mechanical products designed and drawn using Autodesk inventor [2]. The sequence in which each product has to be developed have been given in Tables 1 to 5 for Bearing. The product Bearing is shown in Figure 1.

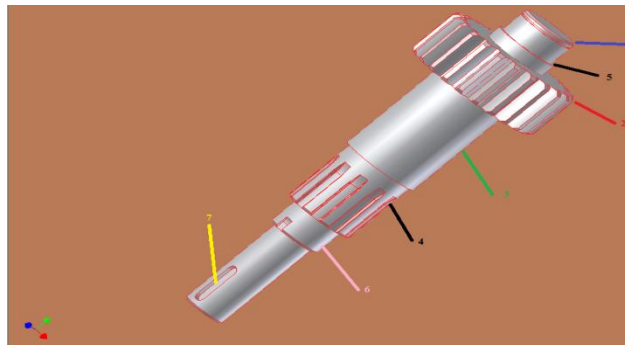

Fig. 1 Bearing

1. Top diameter
2. Gear teeth
3. Support shank
4. Slotted groove
5. Stepped diameter
6. Single slot step
7. Locking slot

In general, the following sequences are formed when creating Bearing [3]. Even though library files are available for Bearing drawing, customized drawing Bearing file is discussed. The major parameters involved in creating the Bearing are wedge, thickness, hole and pin [4]. The various constraints that have to be imposed during modifications of features by many transactions on this Bearing are

- During diameter modification, chamfering has to be locked
- During length or depth modification, diameter has to be locked.

This Bearing has two major entities.

- ❖ Features 1,5,3,6,7 (set 1)
- ❖ Features 2,4 (set 2)

Set 1 and set 2 can be made into individual drawing part files (part file 1 and part file 2) and combined into one assembly file (containing the part files 1 and 2 are intact). When the transactions are accessing individual part files, then transactions in part file 1 need not worry about the type of transactions in part files 2 and vice versa [5]. When the part files 1 and 2 are combined into a single assembly file, then inconsistency in the shape and dimension of the set 1 and set 2, during matching should not occur [6]. Provisions can be made in controlling the dimensions and shapes with upper and lower limits conforming to standards. At any part of time when a subsequent of transaction is trying access locked features, it can modify the features on his system and store as an additional modified copy of the features with time stamping and version names (allotted by the transaction/ allotted by the system) [7].

Let us assume that there are two transactions editing the Bearing. Transaction1 edits O_1 and hence O_2, O_3, O_4, O_6 , will be locked sequentially (Table 1). Immediately transaction2 wants to edit O_2 or O_4 or O_7 , however it will not get transaction as already O_2 is locked [9]. However, transaction 2 or any other transaction can try to access O_6 .



International Journal of Innovative Research in Computer and Communication Engineering

(An ISO 3297: 2007 Certified Organization)

Vol. 2, Issue 11, November 2014

Group	First feature	Remaining feature to be locked
G ₁ bearing	1	2,3,4,6
G ₂ bearing	2	3
G ₃ bearing	4	3,6
G ₄ bearing	7	6

Initially, transaction 1 and transaction 2 have opened the same Bearing file from the common database [8]. The following steps shows sequence of execution and results.

Step 1: T₁ edits O₁ with write mode. Table 2, shows pattern formed for the OL training.

Object number	Input pattern	Target output pattern
O ₁	[1]	[0 1 0]

Step 2: The transaction manager locks objects mentioned in the third column of Table 1 Repeat step 1 with the patterns given in Table 3 [10].

Object number	Input pattern	Target output pattern
O ₁	[1]	[0 1 0]
	[3]	[0 1 0]

Step 3: A new transaction T₂ access O₇. A pattern is formed to verify if lock has been assigned to O₂ and its associated objects O₃. Only when the locks are not assigned to O₂ and O₃ then T₂ is allowed [11].

The patterns of additional transactions are presented to the OL testing module to find if the output [0 0 0] is obtained in the output layer. In such case, transaction is denied for T₂. Else the following Table 4 is presented in step 1 [12].

Step 4: To know the type of lock value assigned to an object and for a transaction, OL testing is used [13, 14]. OL testing uses the final weights created by OL training. Table 5 gives the number of objects in each component used for the case study.

Object number	Input pattern	Target output pattern
O ₁	[1]	[0 1 0]
O ₂	[2]	[0 1 0]
O ₃	[3]	[0 1 0]
O ₄	[4]	[0 1 0]
O ₆	[6]	[0 1 0]

International Journal of Innovative Research in Computer and Communication Engineering

(An ISO 3297: 2007 Certified Organization)

Vol. 2, Issue 11, November 2014

Table 5 Number of objects linked in each group

Group number	Bearing
1	5
2	2
3	3
4	2
5	x

2.1 Implementation of CAD Bearing Object Data Training and Testing Using Fuzzy Logic

Fuzzy Logic (FL) is a multi-valued logic that allows intermediate values to be defined between conventional evaluations like true/false, yes/no, high/low. Fuzzy systems are an alternative to traditional notions of set membership and logic [15].

The training and testing fuzzy logic is to map the input pattern with target output data [18, 19]. For this, the inbuilt function has to prepare membership table and finally a set of number is stored. During testing, the membership function is used to test the pattern [16].

2.1.1 Training Fuzzy logic

- Step 1:** Read the pattern and its target value.
- Step 2:** Create Fuzzy membership function.
- Step 3:** Create clustering using K-Means algorithm.
- Step 4:** Process with target values.
- Step 5:** Obtain final weights.

2.1.2 Testing Fuzzy logic

- Step 1:** Input a pattern.
- Step 2:** Process with Fuzzy membership function.
- Step 3:** Find the cluster to which the pattern belongs [17].
- Step 4:** Obtain estimated target values.
- Step 5:** Classify the status

3. RESULTS

Figures 2 to 5 shows the performance of Concurrency Control during locking and releasing of bearing object. For bearing object the performances have been evaluated using fuzzy logic under controlled Environment.

BEARING DRAWING

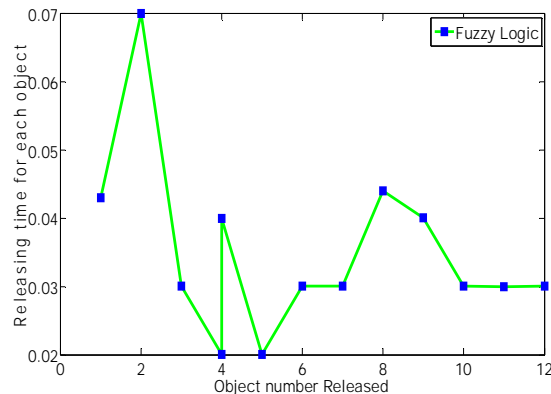

Fig. 2 Releasing time for each object in Bearing

International Journal of Innovative Research in Computer and Communication Engineering

(An ISO 3297: 2007 Certified Organization)

Vol. 2, Issue 11, November 2014

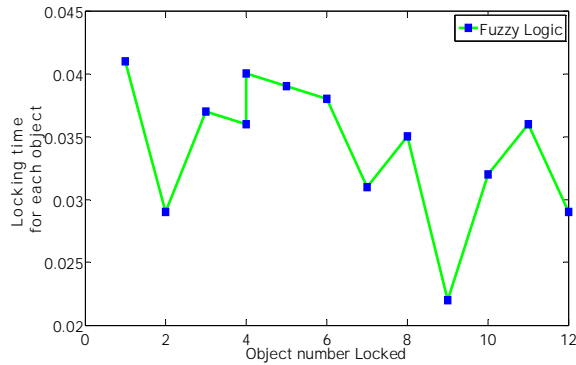

Fig.3 Locking time for each object in Bearing

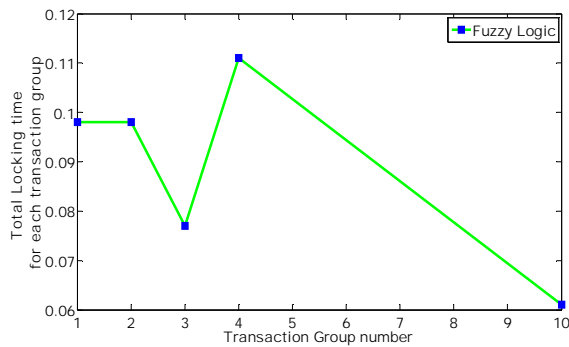

Fig. 4 Total Locking time for each transaction group in Bearing

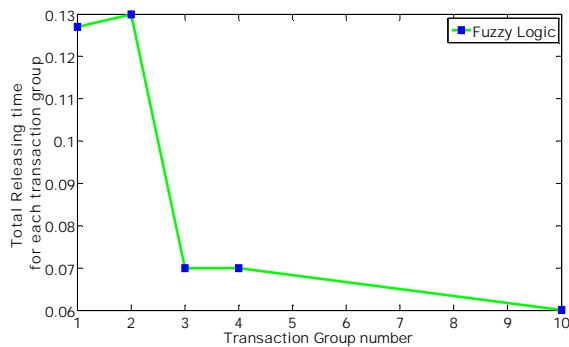

Fig. 5 Total Releasing time for each transaction group in Bearing

III. CONCLUSION

A Fuzzy Logic has been implemented for providing concurrency control to maintain consistency in the CAD database. The performance of the Fuzzy logic algorithm is based on the Locking time and releasing time for each object, Total Locking time for each transaction group, Total Releasing time for each transaction group and Computation complexity. The FL algorithm takes less number of iterations to reach a stable state.



International Journal of Innovative Research in Computer and Communication Engineering

(An ISO 3297: 2007 Certified Organization)

Vol. 2, Issue 11, November 2014

REFERENCES

- [1] Bhavani Thuraisingham and Hai-Ping Ko, 1993, Concurrency control in trusted database management systems: a survey, In ACM SIGMOD Record, Vol. 22, No. 4, pp. 52 – 59.
- [2] Udayakumar R., Khanaa V., Saravanan T., "Analysis of polarization mode dispersion in fibers and its mitigation using an optical compensation technique", Indian Journal of Science and Technology, ISSN : 0974-6846, 6(S6) (2013) pp. 4767-4771.
- [3] Sibsankar Haldar and Paul Vitanyi, 2002, Bounded Concurrent Timestamp Systems Using Vector Clocks, Journal of the ACM, Vol. 49, No. 1, pp. 101–126.
- [4] Mohammed Khaja Nizamuddin, Dr. Syed Abdul Sattar, 2011, "An Improved, Prioritized Concurrency Control Scheme With Performance Gain In Mobile Environments", Arpn Journal of Systems And Software, Vol.1 No. 1.
- [5] Udayakumar R., Khanaa V., Saravanan T., "Chromatic dispersion compensation in optical fiber communication system and its simulation", Indian Journal of Science and Technology, ISSN : 0974-6846, 6(S6) (2013) pp. 4762-4766.
- [6] Voelcker, H.B., et. al, Aug. 1978, The PADL-I/O/2 System for Defining and Displaying Solid Objects, Computer Graphics, Vol.12, No.3, pp. 257-263.
- [7] K. Chitra1, Al-Dahoud Ali, 2011, "Concurrency Control And Consistency Maintenance With Dtd And Ssm For Weakly Connected Environments", 978-0-9564263-7/6 © IEEE.
- [8] Udayakumar, R., Khanaa, V., Saravanan, T., "Synthesis and structural characterization of thin films of SnO_2 prepared by spray pyrolysis technique", Indian Journal of Science and Technology, ISSN : 0974-6846, 6(S6) (2013) pp.4754-4757.
- [9] Christoph Reinke, Nils Hoeller, Stefan Werner, Sven Groppe, Volker Linnemann, 2011, "Analysis And Comparison Of Concurrency Control Protocols For Wireless Sensor Networks", IEEE, pp. 1 – 6.
- [10] Cosmin Stoica Spahiu, 2011, "Concurrency Control Techniques for a Multimedia Database System", Proceedings of The Federated Conference On computer Science And Information Systems, pp. 751–754.
- [11] Uma Mageswaran, S., Guna Sekhar, N.O., "Reactive power contribution of multiple STATCOM using particle swarm optimization", International Journal of Engineering and Technology, ISSN : 1793-8236, 5(1) (2013) pp. 122-126.
- [12] Lawrence A. Soltis, P.E., "Bolted Connection Research: Present and Future", Wood Design Focus, Vol. 5, No.2. pp. 3-5.
- [13] Richard L. Simon, 1983, CAD/CAM - The Foundation for Computer Integrated Manufacturing, In Proceedings of 20th ACM/IEEE Design Automation Conference, pp. 686-700.
- [14] K. Chitra1, Al-Dahoud Ali2, 2011, "Concurrency Control and Consistency Maintenance with DTD and SSM For Weakly Connected Environments", IEEE, pp. 253 -257.
- [15] Vidyalakshmi K., Kamalakannan P., Viswanathan S., Ramaswamy S., "Antinociceptive effect of certain dihydroxy flavones in mice", Pharmacology Biochemistry and Behavior, ISSN : 0091-3057, 96(1) (2010) pp. 1-6.
- [16] Samir Kumar Ghosh, Md. Shohidul Islam, S. Member, IEEE, Md. Anisur Rahman, 2009, "On Analytical Performance Measurement of Concurrency Control Protocols in DBMS", International Journal of Computer and Electrical Engineering, Vol. 1, No. 3, pp. 284 - 287.
- [17] Tei-Wei Kuo, Member, IEEE, Jun Wu, and Hsin-Chia Hsih, 2002, "Real-Time Concurrency Control in a Multiprocessor Environment", IEEE Transactions on Parallel and Distributed Systems, Vol. 13, No.6, pp. 659 - 671.
- [18] William Kent, 1979, Limitations of Record-Based Information Models, In ACM Transactions on Database Systems, Vol. 4, No. 1, pp. 107-131.
- [19] Salem, K., Garcia-Molina, H., and Alonso, R., September 1987, Altruistic Locking: A Strategy for Coping with Long Lived Transactions. Proceedings of the 2nd International Workshop on High Performance Transaction Systems, pp.19.1 - 19.24.
- [20] R.Karthikeyan, Dr.S.R.Suresh, An Approach for Real Time Testing Reliability & Usability Testing Process, International Journal of Innovative Research in Computer and Communication Engineering, ISSN (Online): 2320 – 9801, pp 644-651, Vol. 1, Issue 3, May 201
- [21] P.Ramya, dr.nalini, effective navigation query results based on biomedical database, International Journal of Innovative Research in Computer and Communication Engineering, ISSN: 2249-0183, pp 36-39, volume 1 Issue 3 No4- Dec 2011
- [22] P.Kavitha, Authentic Learning Activities with Pedagogical Stylistics – Enhancing InE-Learning Websites, International Journal of Innovative Research in Computer and Communication Engineering, ISSN(Online): 2320-9801, pp 1211-1215, Volume 1, Issue 6, August 2013
- [23] N.Priya, VANET Based Adaptive Traffic Signal Control, International Journal of Innovative Research in Computer and Communication Engineering, ISSN(Online): 2320-9801, pp 1201-1208, Vol. 1, Issue 6, August 2014
- [24] N.Sakthi Priya, Cervical Cancer Screening and Classification Using Acoustic Shadowing, International Journal of Innovative Research in Computer and Communication Engineering, ISSN(Online): 2320-9801, pp 1676-1679, Volume 1, Issue 8, October 2013