



International Journal of Innovative Research in Computer and Communication Engineering

(An ISO 3297: 2007 Certified Organization)

Vol. 3, Issue 7, July 2015

TRANSINFORMER – An Integrated System for Health Monitoring of Power Transformers

Raja Saranya Gopi¹, P. Thamarai*²

¹Assistant Professor, Dept. of ECE, Jerusalem College of Engineering, Chennai, Tamil Nadu, India

²Assistant Professor, Dept. of ECE, Bharath University, Chennai, Tamil Nadu, India

* Corresponding Author

ABSTRACT: Transformers play an important role in the efficient transmission of electricity. Regular monitoring and maintenance can make it possible to detect new flaws before much damage has been done. Current systems can provide information about the state of a transformer, but they are either offline or very expensive to implement. This Monitoring system is primarily health monitoring equipment that can acquire, process, analyze & communicates the critical parameters to the concerned official who is at a remote place with the help of Auto dialing unit. Not only the conventional technical data, such as current, voltage, etc., but also other critical information such as frequency, oil temperature, oil level etc. of transformers are required by the operators to ensure reliable power delivery and to assist the day-to-day decision making activities. Thus, the system increases the reliability of distribution network.

KEYWORDS: Transformers, electricity, Transmission & Distribution System, Auto dialing unit.

I. INTRODUCTION

Power transformers are at the heart of electrical transmission and distribution systems, and as competition increases within the energy sector, so does the pressure on transformer manufacturing industry to improve reliability and reduce costs of transformers. Usually power transformers have a 20-35 year design life [3]. In practice, a transformer can reach 60 years of useful life if it is properly operated and maintained. With the normal aging, their internal condition degrades, which increases the risk of failure. Traditionally, the evolution of these faults was accompanied with preventative maintenance programs combined with regular tests. With deregulation, it has become necessary to reduce maintenance costs and equipment inventories, thus there is a trend in the industry to move from traditional time-based maintenance programs to condition based maintenance [4-5].

Considering the long service life of a power transformer and prevalent use of human judgment (expert), there is a need to structure a knowledge base around expert knowledge while continuing to create new diagnostic capabilities which can be plugged in. This paper intends to present a monitoring system for integrated fault diagnosis of power transformers. The monitoring system can be integrated along with plant controlled system allowing smooth operation and reduce interfaces between different system. The equipment is permanently mounted on the transformer and provide 24/7 access to current operational data. The system has no moving parts hence it needs less maintenance. And also it reduces transformers operational and maintenance cost by providing long life time.

The system is compact and can be enhanced for additional requirements that may be needed in future. The ultimate objective is to monitor the critical parameters and to inform the observed data to the concerned official [1-2].

II. POWER TRANSFORMER FAULTS AND EFFECTS

Transformer failure will occur due to various causes and conditions. Table I shows the primary cause of transformer failures reported by HSB survey over the last several decades, and identifies those areas where failure-reducing efforts can best be directed. The table lists the most common causes of failures and the percentage of all the failures they represent for the studies conducted in 1975, 1983 and 1998. The information is presented here for comparison purposes, but no conclusions on trends should be made [6-8]. Typical causes include

International Journal of Innovative Research in Computer and Communication Engineering

(An ISO 3297: 2007 Certified Organization)

Vol. 3, Issue 7, July 2015

TABLE I
CAUSES OF TRANSFORMER FAILURE

	1975	1983	1998
Lightning Surges	32.3%	30.2%	12.4%
External Short Circuits	13.6%	18.6%	21.5%
Poor workmanship	10.6%	7.2%	2.9%
Deterioration of insulation	10.4%	8.7%	14%
Overloading	7.7%	3.2%	2.4%
Inadequate Maintenance	6.6%	13.1%	11.3%
Loose connection	2.1%	2.0%	6.0%
All others	6.9%	8.2%	24.2%

external factors such as lightning strikes, system overload short circuit and internal factors such as insulation deterioration, loss of winding clamping, overheating, presence of oxygen, moisture, and solids in the insulating oil [9].

A. Traditional Diagnostic Methods

1. Dissolved Gas Analysis: By means of this analysis, it is possible to identify faults such as partial discharge, overheating and arcing in a great variety of oil filled equipment. And also this analysis shows the distribution of key gases dissolved in the oil.
2. Insulating Oil Quality: A combination of electrical, physical and chemical test is performed in order to measure the changes in electrical properties, extend of contamination and the degree of deterioration in the transformer oil.
3. Thermography: This is an online diagnostics method to check the external surface temperature of the transformer with the help of infrared emission testing method.

In order to assess the overall condition of the power transformer several monitoring methods are used and are still under investigation.

III. PROPOSED MONITORING SYSTEM

The Proposed monitoring system shown in Figure 1 is designed using P89V51RD2 Microcontroller [10]. The system consist of Sensing units designed using MSP 430 Processor, which collects the critical parameters such as current, voltage, frequency, oil level and its temperature from the transformer. The LCD display connected to the processing unit displays the corresponding parameter values for any technical assistance. The microcontroller is programmed in such a manner that it continuously scans the transformer and updates the parameters at every instance of time [11]. The scanned values are directly given to one of the input port of the microcontroller, whereas the display is connected to another input port and voice player unit is connected to the output port. The microcontroller was connected to LCD and output port through their respective interfacing ICs.

A. Voltage & Current monitor

This unit checks whether the incoming voltage and current falls within the threshold limit, if it violates, the incoming voltage and current is given to analog pin of microcontroller with the help of potential transformer and current transformer respectively [12].

B. Frequency counter

International Journal of Innovative Research in Computer and Communication Engineering

(An ISO 3297: 2007 Certified Organization)

Vol. 3, Issue 7, July 2015

This module is designed with the help of IC555 Timer which is wired as a monostable multivibrator. Input signal is compared with the standard pulse rate and the result is displayed in the moving coil meter [13-14]. Resulted analog signal from the moving coil meter is digitized and given to the microcontroller. Since the counter used the seven digits to display the incoming signal, it can operate as 5-decimal point MHz range frequency counter.

C. Voice Player

This block consists of IC STA013 based voice player [15]. By using this player we can store voice up to 100 minute, it also has feature to divide the total time into desired tracks. This operation is

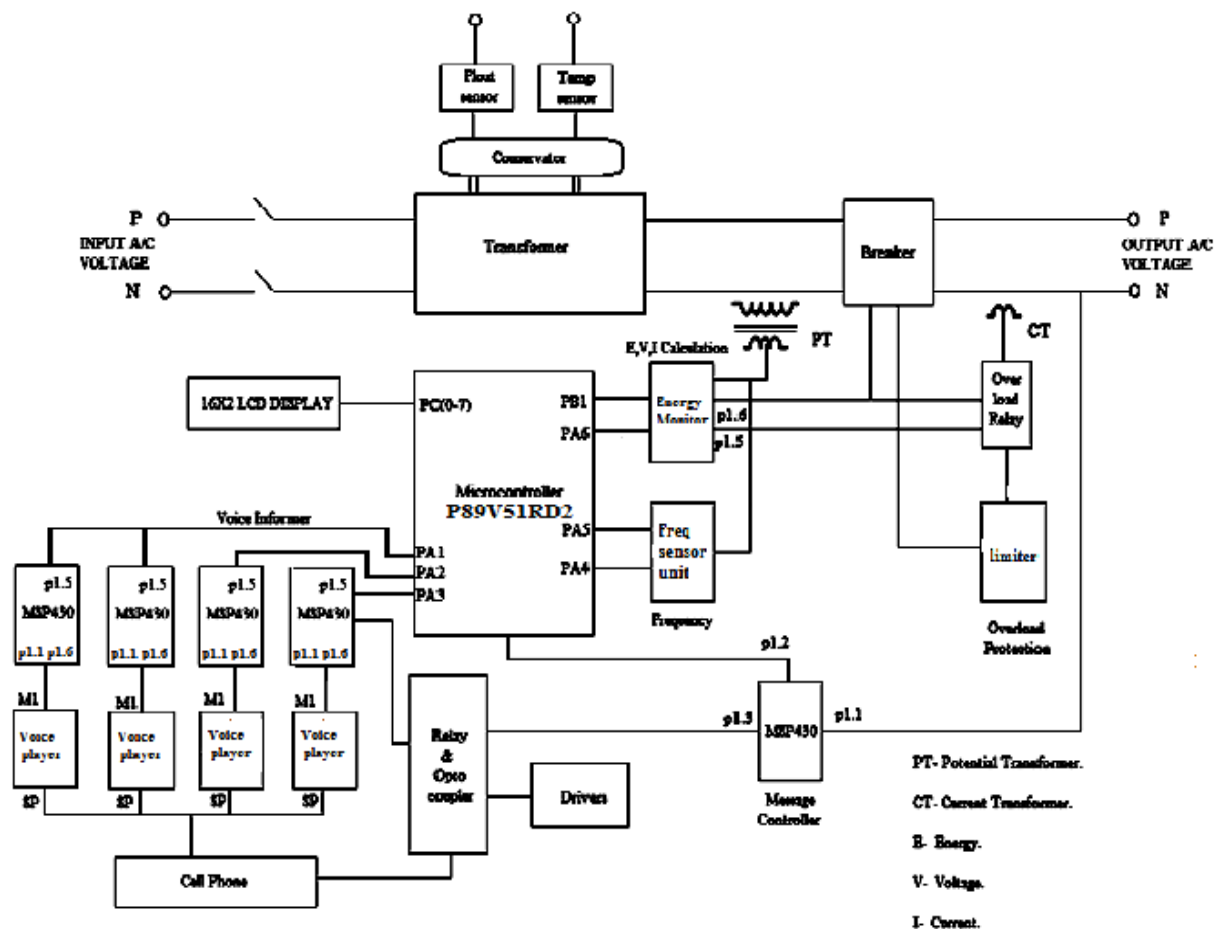

Figure No 1: Block Diagram of Proposed Monitoring System

possible by assigning the status of message selection pin. The recording and playing is done using record and play pin at ground status. When the LCD is connected to the player, its 12 additional pushbuttons can be used to control the player [16-17].

D. Auto Dialing Unit

The auto dialing system consists of relay to dial the pre stored number to concerned person. Once the call is answered the unit either plays a recorded message or recorded voice [18]. By adding external push buttons it is possible to support telephone numbers up to twenty digits each. With the help of quick dialing method, auto dialing is carried on.

IV. RESULTS

The Performance of the proposed monitoring system has been analyzed by applying various types of inputs to the Transformer. From the result observed, it is understood that, the proposed system monitors and controls the

International Journal of Innovative Research in Computer and Communication Engineering

(An ISO 3297: 2007 Certified Organization)

Vol. 3, Issue 7, July 2015

transformer in an efficient manner and also shut down the entire unit if dangerous condition occur. Thus, it safeguards the transformer from any damage. The photographs of project testing are shown in Fig No: 2 to Fig No: 5 and observed results are tabulated in Table II.



Figure No 2: Temperature sensing unit

**TABLE II
OBSERVED EXPERIMENTAL RESULTS**

Incoming Parameters	Range	Monitoring system action	Transformer status
Voltage & Current	Std +/- 20V, 20A	No change in relay position.	Under safe operation.
	> or < Std +/- 20V, 20A	Relay closes & information is send to concern by Auto dialing unit.	Tripped off.
Frequency	Std +/- 1 Hz	No change in relay position.	Under safe operation.
	> or < Std +/- 1 Hz	Moving coil meter output changes the relay position & information is send.	Tripped off.
Oil temperature	Std +/- 20 deg.c	No change in relay position.	Under safe operation.
	> or < Std +/- 20 deg.c	Sensor output closes the relay& information is send.	Tripped off.
Oil level	Full	No change.	Under safe operation.
	Medium	LCD in the system displays the level in the tank.	Under safe operation.
	Minimum	Comparator output send signal to switching circuit & information is send.	Tripped off.



Figure No 3: Voltage monitoring unit

International Journal of Innovative Research in Computer and Communication Engineering

(An ISO 3297: 2007 Certified Organization)

Vol. 3, Issue 7, July 2015

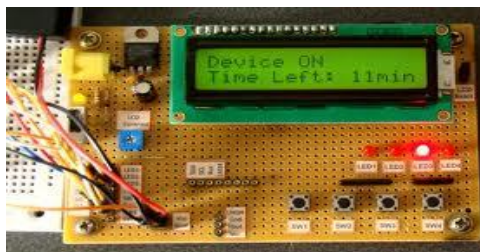

Figure No 4: Transformer Tripper

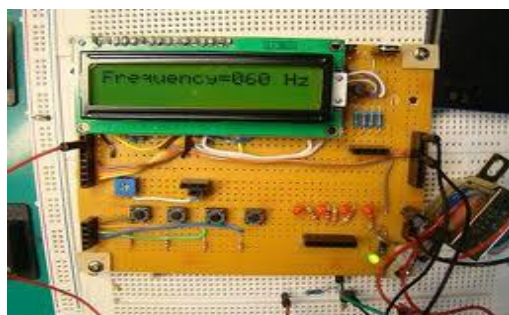

Figure No 5: Frequency counter

V. CONCLUSION

Transformer monitoring is an expanding field of study. The monitoring system presented in this paper can be enhanced to provide more and more valuable information on the health of a transformer. The potential of this system is vast and with further investigation, the concept of an intelligent diagnostic for transformer or even substation level can be realized. The result of this paper, which is designed for monitoring critical parameters of the transformer, shows great promise on being a successful monitoring system for high voltage transformers. The proposed design of the system makes the power transformer more robust against some key power quality issues which makes the voltage, current or temperature to peak. With Ethernet connectivity, we can easily connect and transmit crucial transformer health data over TCP/IP to SCADA and also Browser-based Graphical User Interface can be used to control the remote transformers. Hence the distribution is made more secure, reliable and efficient by means of the proposed monitoring system.

REFERENCES

1. Alessandro Ferrero, "Measuring electric Power quality: Problems and Perspectives", Measurement Vol.41, No.2, pp 121-129, Feb 2008.
2. Argonne National Laboratory, "Assessment of the potential costs and energy impacts of spill prevention, control and countermeasure equipments for Electric Utility substation", Draft energy impact issue paper, 2006.
3. Kumar S., Das M.P., Jeyanthi Rebecca L., Sharmila S., "Isolation and identification of LDPE degrading fungi from municipal solid waste", Journal of Chemical and Pharmaceutical Research, ISSN : 0975 – 7384 5(3) (2013) pp.78-81.
4. Jyotishman Pathak, Yuan Li, Vasant Honavar and JamesD.McCalley, "A Service-Oriented Architecture for Electric Power Transmission System Asset Management", In ICSOC Workshop, pp 26-37, 2006.
5. Morais D.R, Rolim J.G and Vale Z.A, "DITRANS-A Multiagent system for integrated diagnosis of Power Transformer", Power Tech IEEE Lausanne, pp 1917-1922, July 2007.
6. Laljee R.P., Muddaiah S., Salagundi B., Cariappa P.M., Indra A.S., Sanjay V., Ramanathan A., "Interferon stimulated gene - ISG15 is a potential diagnostic biomarker in oral squamous cell carcinomas", Asian Pacific Journal of Cancer Prevention, ISSN : 1513-7368, 14(2) (2013) pp.1147-1150.
7. Naresh.R, Veena Sharma and Manisha vashisth, "An Integrated Fuzzy approach for fault diagnosis of Transformers", IEEE Transactions on Power Delivery, Vol 23, No.4, pp 2017-2024, Oct 2008.
8. Negenborn.R.R, Beccti.A.G, Demiray.T, Leirens.S, Damm.G,
9. DeSchutter.B and Morari.M, "Supervisory hybrid model predictive control for voltage stability of power networks", Proceedings of the 2007 American Control Conference, New York, pp: 5444-5449, July 2007.
10. Overby and Weber, "Visualization of power system data", in proceedings of 33rd annual Hawaii international conference on system science, Jan 2000.



ISSN(Online): 2320-9801
ISSN (Print): 2320-9798

International Journal of Innovative Research in Computer and Communication Engineering

(An ISO 3297: 2007 Certified Organization)

Vol. 3, Issue 7, July 2015

11. Subha Palaneeswari M., Ganesh M., Karthikeyan T., Manjula Devi A.J., Mythili S.V., "Hepcidin-mini-review", Journal of Clinical and Diagnostic Research, ISSN : 0973 - 709X, 7(8) (2013) pp.1767-1771.
12. Pudlo.G, Tenbohlen.S, Linders.M and Krost.G, "Integration of Power Monitoring and overload calculation into the power system control surface", IEEE/PES Transmission and Distribution Conference and Exhibition, Vol: 1 pp 470-474, 2002.
13. Thomas J., Ragavi B.S., Raneesha P.K., Ahmed N.A., Cynthia S., Manoharan D., Manoharan R., "Hallermann-Streiff syndrome", Indian Journal of Dermatology, ISSN : 0019-5154, 58(5) (2013) pp.383-384.
14. Richard Zurawski, "Embedded systems Handbook", Published by CRC Press, ISBN, 2006.
15. Steve Heath, "Embedded systems Design", Published by Butterworth-Heinemann, second edition, 2003.
16. Thiyagarajan and Palanivel, "An efficient monitoring of substations using microcontroller based monitoring system", International Journal of Research and Review of Applied Science, Vol: 4, No.1 pp 6368, July 2010.
17. Subhashini V., Ponnusamy S., Muthamizhchelvan C., "Growth and characterization of novel organic optical crystal: Anilinium d-tartrate (ADT)", Spectrochimica Acta - Part A: Molecular and Biomolecular Spectroscopy, ISSN : 1386-1425, 87() (2012) pp.265-272.
18. Wang.M, Vandermaar A.J and Srivastava K.D, "Review of condition assessment of Power Transformer in service", IEEE Electrical insulation magazine Vol: 18, No.6, pp 12-25, Nov-Dec 2002.
19. Xiaomeng Li and Ganesh K.Venayagamoorthy, "A Neural Network based Wide Area Monitor for a Power System", IEEE Power Engineering Society General meeting, Vol: 2, pp: 1455-1460, 2005.
20. B Karthik, S Rajeswari, Design and Analysis of a Transceiver on a Chip for Novel IR-UWB Pulses, Middle-East Journal of Scientific Research 19 (6), PP 817-820, 2014.
21. Shriram, Revati; Sundhararajan, M; Daimiwal, Nivedita; , Application of High & Low Brightness LEDs to Human Tissue to Capture Photoplethysmogram at a Finger Tip, Red, V-620, PP 700.
22. Muralibabu, K; Sundhararajan, M; , PAPR performance improvement in OFDM system using DCT based on adjacent symbol grouping, Trans Tech Publ, Applied Mechanics and Materials, V-550, PP 204-209, 2014.
23. sivaperumal, s; sundhararajan, m; , advance feature extraction of mri brain image and detection using local segmentation method with watershed.
24. MURALIBABU, K; SUNDHARARAJAN, M; , PAPR reduction using DCT based sub carrier grouping with Companding Technique in OFDM system.
25. Kanniga, E; Srikanth, SMK; Sundhararajan, M; , Optimization Solution of Equal Dimension Boxes in Container Loading Problem using a Permutation Block Algorithm, Indian Journal of Science and Technology, V-7, I-S5, PP 22-26, 2014.