



IJIRCCCE

e-ISSN: 2320-9801 | p-ISSN: 2320-9798



INTERNATIONAL JOURNAL OF INNOVATIVE RESEARCH

IN COMPUTER & COMMUNICATION ENGINEERING

Volume 11, Issue 4, April 2023

ISSN INTERNATIONAL
STANDARD
SERIAL
NUMBER
INDIA

Impact Factor: 8.379

9940 572 462

6381 907 438

ijircce@gmail.com

www.ijircce.com

Password Based Circuit Breaker Control

Prof.Sushma Patwardhan, Sanket Pawar, Vaishnavi Jadhav, Nikhil Lamture

Assistant Professor, Dept. of E& TC, GS Moze College of Engineering , Balewadi, Pune, India

Dept. of E& TC, GS Moze College of Engineering, Balewadi, Pune, India

Dept. of E& TC, GS Moze College of Engineering, Balewadi, Pune, India

Dept. of E& TC, GS Moze College of Engineering, Balewadi, Pune, India

ABSTRACT: The major problem in the power system is the electrical accidents while repairing the electrical lines due to the lack of communication between the electrical substation and maintenance staff. This project gives a solution to this problem to ensure line man safety. Also the load distribution system has been proposed in which sharing of the load is done between village side and city side.

KEYWORDS: circuitbreaker, Manualloadsharing, Voltage Regulator.

I.INTRODUCTION

Now a days, electrical accidents of the line man are increasing while repairing the electrical lines due to lack of communication between the electrical substation and maintenance staff. This paper gives a solution to this problem to ensure line man safety. In this proposed system the control(ON/OFF) of the electrical lines lies with line man. This paper is arranged in such a way that maintenance staff or line man has to enter the password to ON/OFF the electrical line. Now if there is any fault in electrical line then line man will switch off the power supply to the line by entering the password and comfortably repair the electrical line, and after coming to the substation line man switch on the supply to the particular line by entering the password. Here, there is also a provision of changing the password. circuit breakers are actually provided as a means of protection to completely isolate the downstream network in the event of a fault . The demand for electrical energy is ever increasing. Today over 21% (theft apart!!) of the total electrical energy generated in India is lost in transmission (4-6%) and distribution (15-18%). The electrical power deficit in the country is currently about 18%. Electric power is normally generated at 11-25kV in a power station. To transmit over long distances, it is then stepped-up to 400kV, 220kV or 132kV as necessary. The demand for electrical energy is ever increasing , to overcome this problem Load sharing concept is included. This paper focusing on village side and city side based on the load demand and the required voltage is transferred from village side to city side and vice versa.

II. LITERATURE SURVEY

The embedded systems are electronic devices which are incorporated microprocessors with in their implementations. The embedded systems designers generally have a significant grasps over hardware technologies. They use specific programming languages and software to develop embedded systems and manipulate the equipment. Embedded systems often use a slow processor and small memory size to minimize costs. An embedded system is a specialpurpose system in which the computer is completely encapsulated by or dedicated to the device or system it controls. Unlike a general- purpose computer, such as a personal computer, an embedded system performs one or a few pre-defined tasks, usually with very specific requirements. Password based circuit breaker: A circuit breaker is an automatically operated electrical switch designed to protect an electrical circuit from damage caused by overload or short circuit. Its basic function is to detect a fault condition and interrupt current flow. Unlike a fuse, which operates once and then must be replaced, a circuit breaker can be reset (either manually or automatically) to resume normal operation. When operated manually we see fatal electrical accidents to the line man are increasing during the electric line repair due to the lack of communication and coordination between the maintenance staff and the electric substation staff. In order to avoid such accidents, the breaker can be so designed such that only authorized person can operate it with a password. Here, there is also a provision of changing the password. The system is fully controlled by the 8 bit microcontroller of 16f877A family. The password is stored in an EEPROM, interfaced to the microcontroller and the password can be changed any time unlike a fixed one burnt permanently on to the microcontroller. A keypad is used to enter the password and a relay to open or close circuit

breaker, which is indicated by a lamp. Any wrong attempt to open the breaker (by entering the wrong password) an alert will be actuated, indicated by another lamp.

III. PROBLEM FORMULATION

In the absence of switches at different points in the distribution network, it is not possible to isolate certain loads when required. However, the circuit breakers are actually provided as a means of protection to completely isolate the downstream network in the event of a fault (short circuit, over load). Using this as a tool for load management is not desirable, as it disconnects the power supply to a very large segment of consumers and blackout over a large section of the distribution network. As we found that if the power in industries is disconnect for a minute is stops the production. So the power in industries should be continues. And when a line man goes to repair the line then by unknowingly or wrong intentionally any one can ON the circuit breaker and line man can be met with fatal accident.

IV. BLOCK DIAGRAM

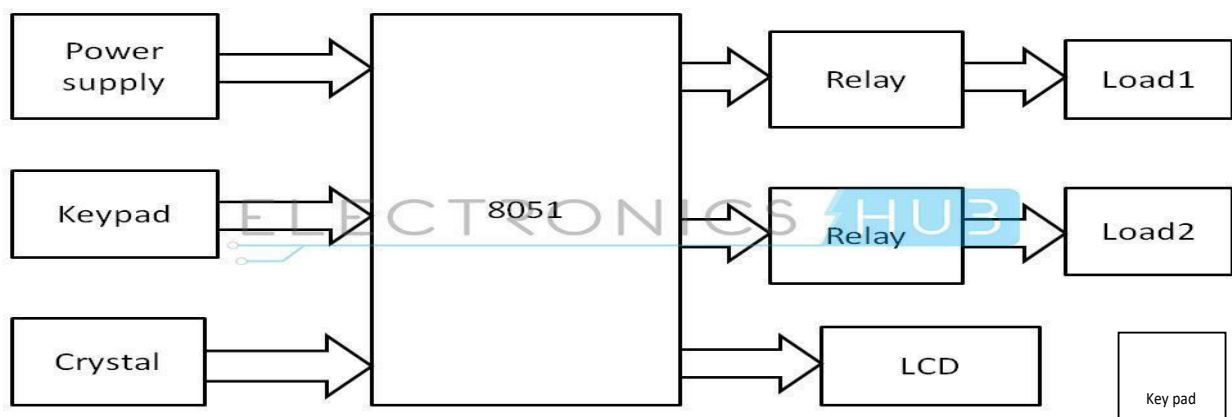

Relay:

A relay is an electrically operated use an electromagnet to mechanically operate a switch, but other operating principles are also used, such as solid-state relays. Relays are used where it is necessary to control a circuit by a low complete electrical isolation between control and controlled circuits), or where several circuits must be controlled by one signal. The first relay long distance telegraph circuits as amplifiers: they repeated the signal coming in from one circuit and re transmitted it on another circuit. Relays extensively in telephone exchanges and early computers to perform logical operations. A type of relay that electric motor or other loads is called a contactor. Solid-state relays control power circuits with no moving parts, instead using a semiconductor device to perform switching. Relays with calibrated operating characteristics and sometimes multiple operating coils are used to protect electrical circuits from overload or faults; in modern electric power systems these functions are performed by digital instruments still called "protective relays".



Microcontroller:

The ATmega32 is a low-power CMOS 8-bit microcontroller based on the AVR RISC architecture. By executing powerful instructions in a single clock cycle, the ATmega32 achieves throughputs approaching 1 MIPS per MHz, allowing the system designer to optimize power consumption versus processing speed. High-performance, Low-power Atmel AVR 8-bit Microcontroller advanced RISC Architecture. It has 131 Powerful

Instructions, most single-clock cycle execution. It contains 32×8 general purpose working registers. It is fully static operation. It is up to 16MIPS throughput at 16MHz. It is On-chip 2-cycle Multiplier. It is high endurance non-volatile memory segments. It contains 32Kbytes of In-system self-programmable flash program. The memory has 1024Bytes EEPROM, 2Kbytes Internal SRAM, Write/Erase cycles: 10,000 Flash/100,000 EEPROM, Data retention: 20 years at 85°C/100 years at 25°C. It is an optional boot code section with independent lock bits. In-System Programming by On-chip Boot Program. It is a True Read-Write Operation. It has a programming lock for software security. It is an Extensive On-chip Debug Support. It has Programming of Flash, EEPROM, fuses and lock bits through the JTAG Interface. It consists of capacitive touch buttons, sliders and wheels. It is up to 64 sense channels.



LCD Display:

The term liquid crystal is used to describe a substance in a state between liquid and solid but which exhibits the properties of both. Molecules in liquid arrange themselves until they all point in the same specific direction. This arrangement of molecules enables the medium to flow as a liquid. Depending on the temperature and particular nature of a substance, liquid crystals can exist in one of several distinct phases. Liquid crystals in a nematic phase, in which there is no spatial ordering of the molecules, for example, are used in LCD technology. Here this is used to display the password entered by us to ON/OFF the circuit breakers.



Keypad:

HEX keypad is a standard device with 16 keys connected in a 4x4 matrix, giving the characters 0-9 A-F. Interfacing of Hex key pad to Atmega32 is essential while designing embedded system projects which require character or numeric input or both. For example projects like digital code lock, numeric calculator etc. Here we are using this to enter numeric password for turn ON/OFF the circuit breaker. This can be easily interfaced with any kit Microcontroller Development Board. It is a four pin tactile switch and four mounting holes 3.2mm each



Resistor:

A resistor is a passive component that implements electrical resistance circuit element. Resistors act to reduce current flow, and, at the same time, act to lower voltage levels within circuits. Resistors may have fixed

resistances or variable crystals tend to be two-terminal electrical as a resistances, such as those found in thermistors trimmers, photoresistors and potentiometers. The current through a resistor is in direct proportion the voltage across the resistor's terminals. R is the resistance of the conductor in units of ohms (symbol: Ω). The ratio of the voltage applied across a resistor's terminals to the intensity of current in the circuit is called its resistance, and this can be assumed to be a constant (independent of the voltage) for ordinary resistors working within their ratings.



CIRCUIT DIAGRAM

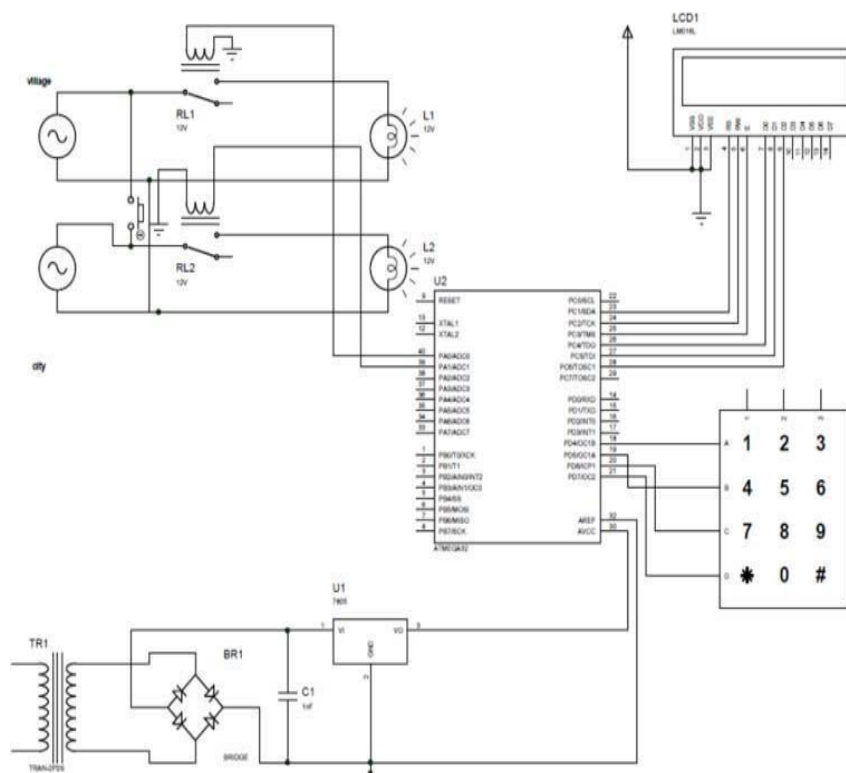

V. WORKING

In this paper, the power is distributed over two sections. First one is supply unit and second one is Breaker unit. Supply unit is converted into 5v and is given to microcontroller. During maintenance maintainer may met with fatal accident. So, for protection of maintainer , relay is operated by password. This is done with the help of microcontroller. First of all the password is preset by programming. When we entered the password by the keypad if it is matched by preset password then the microcontroller sends a signal to trip the password based relay. And again when maintenance is done, password to be enter and if it matched with preset password, signal is send by microcontroller and relay ON. Village area and city area run by separate supply voltage. If the demand needed



for either village or city area based on the available power is sharing between two area .The load demand is occurred, the maintainer entering the password to operate the switch the load will share,otherwise switch is opened.

ADVANTAGES

- Improves Lineman safety
- Electrical accidents can be avoided.
- Easy of operation
- Maintance will be simple.

APPLICATIONS

- It can be used any where in the substation to trip the circuit.
- Most useful to operate in the public areas.

VI. CONCLUSION

It can work on given known password and it gives no scope of password stealing. It ensures the line man safety and it reduces load demand in the distribution side. There is also a provision of changing the password.

REFERENCES

- [1] T. B. Smith, "Electricity theft: a comparative analysis," Elsevier Journal Energy Policy, vol. 32, no. 18, pp. 2067-2076, Dec. 2004.
- [2] A. J. Dick, "Theft of electricity-how UK electricity companies detect and deter," in proceedings of European Convention on Security and Detection, pp. 90-95, May 1995.
- [3] C.J. Bandim, J.E.R. Alves Jr., A.V. Pinto Jr., F.C. Souza, M.R.B. Loureiro, C.A. Magalhaes, and F. Galvez-Durand, "Identification of energy theft and tampered meters using a central observer meter: a mathematical approach," in proceedings of IEEE PES Transmission and Distribution Conference and Exposition, vol. 1, pp. 163-168, Sept. 2003.
- [4] S.S.S.R. Depuru, L. Wang, and V. Devabhaktuni, "A conceptual design using harmonics to reduce pilfering of electricity," in proceedings of IEEE Power and Energy Society General Meeting, pp. 1-7, Jul. 2010.



INNO  **SPACE**
SJIF Scientific Journal Impact Factor
Impact Factor: 8.379



ISSN INTERNATIONAL
STANDARD
SERIAL
NUMBER
INDIA



INTERNATIONAL JOURNAL OF INNOVATIVE RESEARCH

IN COMPUTER & COMMUNICATION ENGINEERING

 **9940 572 462**  **6381 907 438**  **ijircce@gmail.com**



www.ijircce.com

Scan to save the contact details