



International Journal of Innovative Research in Computer and Communication Engineering

(An ISO 3297: 2007 Certified Organization)

Website: www.ijirccce.com

Vol. 5, Issue 10, October 2017

Survey on Real Time Tracking of Malicious Activities Occurring Internally on the System

Mashhood Sayed¹, Supriti Sinha², Ria Matapurkar³, Danish Shaikh⁴, Prof. Kanchan Wankhade⁵

UG Students Department of Computer Engineering, Dhole Patil College of Engineering, Wagholi, Near Eon IT park.,
Pune, Maharashtra, India^{1,2,3,4}

Assistant Professor, Department of Computer Engineering, Dhole Patil College of Engineering, Wagholi, Near
Eon IT park, Pune, Maharashtra, India⁵

ABSTRACT: An Internal Intrusion Detection and Protection System by Using Data Mining and Forensic Techniques (IIDPS) play a significant role in computer security. In network surroundings IIDPS find the activities that have an effect on Confidentiality, Integrity and accessibility on network knowledge. Currently, most computer systems use user IDs and passwords because the login patterns to verify users. However, many of us share their login patterns with co-workers and request these coworkers to help co-tasks, thereby creating the pattern united of the weakest points of computer security. Insider attackers, the valid users of a system who attack the system internally, are hard to find since most intrusion detection systems and firewalls establish and isolate malicious behaviors launched from the external world of the system solely. Additionally, some studies claimed that analyzing system calls (SCs) generated by commands will establish these commands, with that to accurately find attacks, with attack patterns are the options of an attack. Therefore, in this project, a security system, named the Host Based Intrusion Detection System (HIDS), is projected to find Insider attacks at SC level by optimizing data processing and rhetorical techniques. The HIDS creates user's personal profiles & log file to stay track of user's usage habits as their rhetorical options and determines whether or not a sound login user is that the account holder or not by scrutinizing his/her current system usage behaviors with the patterns collected within the account holder's personal profile & log file. When intrusion is detected then image will be captured by system and then will send it to administrator and then system will automatically shutdown as the intrusion is detected.

KEYWORDS: Insider attack, Log file, HIDS, IIDPS, System call, Digital forensic techniques.

I. INTRODUCTION

In the past 10 years, computer systems have been largely employed to provide users with easier and more perfect lives. However, System securities is the one of the serious issue in computer domain when users take advantages of powerful capabilities since attackers very usually try to forcibly enter in the computer systems and behave spitefully or harmfully, e.g. corrupt critical data of a company, making the systems out of work or destroying the systems. pharming attack, distributed denial-of-service (DDoS), eavesdropping attack, and spear-phishing attack generally all this attack are well known attacks [1], [2], insider attack is most difficult for the detected because firewalls and intrusion detection systems (IDSs) normally fight against outside attack. Now a days, To Authentic users, most systems check user ID and password as a login pattern. However, attackers may be install Trojan to hack the password and When successful, they may then log in to the system, access users' private files, or modify or destroy system settings. Fortunately, most current host-based security systems [3] and network-based IDSs [4], [5] can discover a known intrusion in a real-time manner. Attack packets are often issued with forged IPs or attackers may enter a system with valid login patterns that's why it's very difficult to identify who is attacker. However in Operating System level system calls (SCs) is more helpful to find out attacker and identify the exact attack [6], processing a large volume of SCs, detecting harmful behaviors from them, and detecting possible attackers for an intrusion are still engineering challenges Therefore, in this paper, we propose a security system, at SC level which detects harmful behaviors launched toward a



International Journal of Innovative Research in Computer and Communication Engineering

(An ISO 3297: 2007 Certified Organization)

Website: www.ijircce.com

Vol. 5, Issue 10, October 2017

system named Internal Intrusion Detection and Protection System (IIDPS). To mine system call patterns (SC-patterns) defined as the longest system call sequence (SC-sequence) that has repeatedly appeared several times in a user's log file for the user the IIDPS uses data mining and forensic profiling techniques. The user's forensic features, define is as an SC Pattern find out in submitted by users SC sequences but normally used by other users computer usage history.

The contributions of this paper are: 1) identify a user's forensic features by analyzing the corresponding SCs to enhance the accuracy of attack detection; 2) able to port the IIDPS to a parallel system to further shorten its detection response time; and 3) effectively resist insider attack.

II. LITERATURE SURVEY

All In Computer forensics science, we can views computer systems as crime scenes, aims to identify, preserve, recover, analyze, and present facts and opinions on information collected for a security event. exactly what attacker done such things will be recognized such as spreading computer viruses, malwares, and malicious codes and conducting DDoS attacks [8]. Intrusion detection techniques most of the focus on how to find harmful network behaviors and based on the histories recorded in log files we acquire the characteristics of attack packets, i.e. attack patterns[11]. In [10] Author used self-developed packets for compare to collect network packets with which to discriminate network attacks with the help of network states and packet distribution. In [4] from system log files we acquired network intrusion and attack patterns. These files contain tracked information of misuse computer. It means that, from synthetically generated log files, these traces or patterns of misuse can be more accurately reproduced. In [3] Author overviewed research progress of applying methods of computational intelligence, including artificial neural networks, fuzzy systems, evolutionary computation, artificial immune systems, and swarm intelligence, to detect malicious behaviors. The author can compare different intrusion systems and systematically summarized the details hence allow us to described existing research challenges. To network security these aforementioned techniques and applications truly work finely. When unauthorized user log in in to the system with valid ID and password that time they not able to easily authentic remote login user and detect specific type of intrusion. In previous work [1], for collects forensic features we can use security system for users at command level rather than at SC level, by invoking data mining and forensic techniques, was developed. Moreover, if attackers use many sessions to issue attacks, e.g., multistage attacks, or launch DDoS attacks, then it is not easy for that system to identify attack patterns. In [4] Author presented an intelligent lightweight IDS with the help with this forensic technique identify users behavior and a data mining technique to carry out cooperative attacks. The authors claimed that the system could detect intrusions effectively and efficiently in real time. However, they did not mention the SC filter. In [9] Author provided another example of integrating computer forensics with a knowledge-based system. For allowing SC Sequence to be executed, the system adopt predefine model. Same will be employed by a detection system to restrict program execution to ensure the security of the protected system. And same will be needful the identified issue a series of harmful SC's and on the knowledge based identified attack sequence which have been collected. When an undetected attack is presented, the system frequently finds the attack sequence in 2 s as its computation overhead. In [7] Author explored the effectiveness of a detection approach based on machine learning to combine the expressive power of generative models with good classification accuracy capabilities to infer part of its knowledge from incomplete training data so that the network anomaly detection scheme can provide an adequate degree of protection from both external and internal menaces. In [4] to enhance the security of advanced metering infrastructure through an IDS Author analyzed the possibility of using data stream mining. The advanced metering infrastructure, is crucial part of smart card which work as bridge for operating both side of information flow between the user's domain and the utility domain.



International Journal of Innovative Research in Computer and Communication Engineering

(An ISO 3297: 2007 Certified Organization)

Website: www.ijirccce.com

Vol. 5, Issue 10, October 2017

Author Name	Paper Name	Year of Publication	Description
S. Gajek, A. Sadeghi, C. Stuble, and M. Winandy	Compartmented security for browsers Or how to thwart a phisher with trusted computing	IEEE Int. Conf. Apr. 2007	For isolating applications of different trust level, and a trusted wallet for storing credentials and authenticating sensitive services, our approach is based on the ideas of compartmentalization. Our solution requires no special care from users once the wallet has been setup in an initial step, for identifying the right Web sites while the disclosure of credentials is strictly controlled. Moreover, a prototype of the basic platform exists and we briefly describe its implementation.
F. Y. Leu, M. C. Li, J. C. Lin, and C. T. Yang	MIS: Malicious Nodes Identification Scheme in Network-Coding-Based Peer-to-Peer Streaming	IEEE March 2010.	In this paper, a novel approach to limiting pollution attacks by rapidly identifying malicious nodes. Scheme carefully satisfy the requirements of live streaming systems, and achieves much higher efficiency than previous schemes. Each node in our scheme only needs to perform several hash computations for an incoming block, incurring very small computational latency
Z. Shan, X. Wang, T. Chiueh, and X. Meng	Safe side effects commitment for OS-level virtualization	ACM Int. Conf. Germany, 2011	In this work, to automatically eliminate malicious state changes when merging the contents of an OS-level VM to the host, we develop a VM commitment system called Secom. Secom consists of three steps: grouping state changes into clusters, distinguishing between benign and malicious clusters, and committing benign clusters. Secom has three novel features
Q. Chen, S. Abdelwahed, and A. Erradi	A New Logging-based IP Trace back Approach using Data Mining Techniques	ACM Cloud Autonomic Computer. Conf. USA, 2013	IP Trace back is a way to search for sources of damage to the network or host computer. IP Trace back method consists of reactive and proactive methods, and the proactive method induces a serious storage overhead. However, a system capable of solving these problems through cluster-based mass storage, digestible packets and hierarchical collections was designed.
KomalBarhate	Automated Digital Forensic Technique with Intrusion Detection Systems	IEEE Trans 2013	In this research work, automated Digital Forensic Technique with Intrusion Detection System is proposed. Once an IDS detects an intrusion, it sends an alert message to administrator followed by invoke the digital forensic tool to capture the state of the system. Captured image can be used as evidence in the court of law to prove the damage.

Table1. Literature Survey

III. PROPOSED SYSTEM

In this approach, log file is stored into two different forms as well as in two different places. Log file in plain text from is stored on target host and a copy of same log file is stored in another host called log manager. When intruder tried to acquire log file IDS running on the based host to detect exact intrusion and then it will be give an alert to security administrator about the intrusion which is take require decision to mitigate them.

A. System Framework:

Target Host

In the Target Host, Crucial data (i.e. log files) is stored. To preserve the integrity and confidentiality need to be Continuous monitor of log file is prime requirement of the data stored in it. To achieve this, IDS is deployed on target host and it is a continuous process round the clock. Whenever an attacker tries to intrude the target host, IDS running

International Journal of Innovative Research in Computer and Communication Engineering

(An ISO 3297: 2007 Certified Organization)

Website: www.ijirccce.com

Vol. 5, Issue 10, October 2017

on target host detects the intrusion; sends an alert message to security center as well as log server. After that it will be capture the state of the system (RAM image and log file image) by using Digital Forensic Tool. Then the captured log file has been compared to previous log file image to confirm the intrusion. Target host is nothing but our OS as it was host based system. The intrusion can try to use information of the system but if he try to make changes in the system properties and access the access the records then IDs comes in to the picture.

Server:

Server maintained the copy of the log file in an encrypted form. Log file maintained the Encryption keys and it kept secret. Periodically back up of the Target host log file is taken and it is stored on the log server.it will be receiving log file as backup and encrypted the file and store within it. Whenever the log server receives an alert message from target host, it decrypts the log file, computes the image of the decrypted log file using digital forensic tool and sends it to the target host to perform the comparison. The main job of the Log server is encryption and decryption of log files such that the intruder doesn't have access to them. If the intruder gets to know the location and condition of the log file shall only be available with the owner and nobody else. It shall be provided at the time of delivering the software as a complete product.

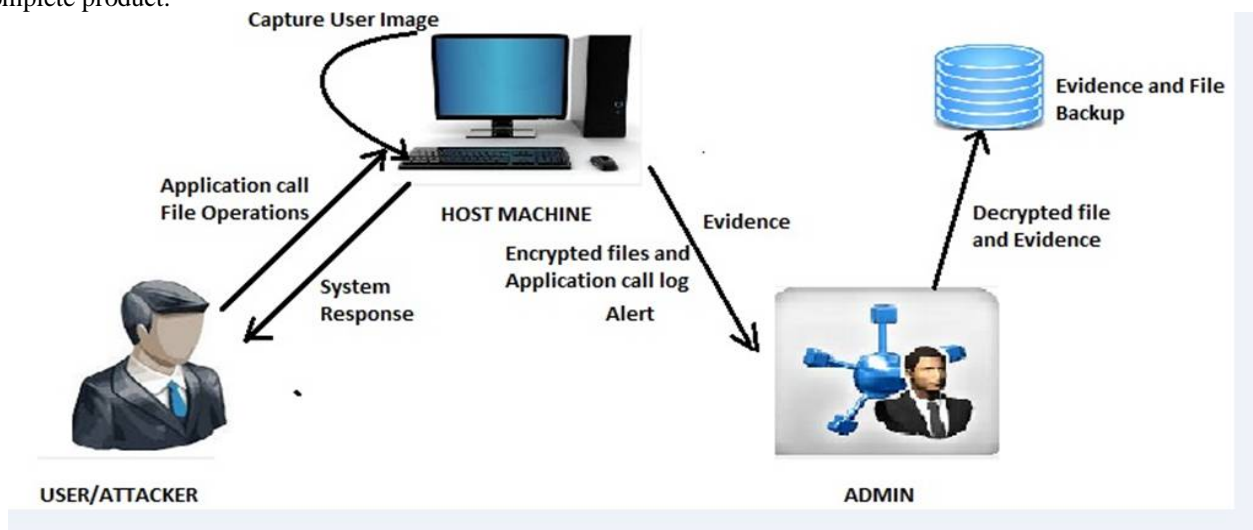

Figure 1: System architecture

Security Centre (Admin):

This is the system used by the security administrator to monitor the alerts generated by IDS. It receives alerts from Target Host. Once the target host has sent the alert to the Security centre, the job of the Security centre starts. The attack is hence detected and looked into at the Security centre. The Security centre is the most essential component of the IDS. Its job is track the intrusion he tries to hack the system, an alert should be sent to the real owner. This will be accomplished by webcam image and same will be prove the again court of law. If the intruder tries to access the files without the net connection, the system shall shut down by itself within 10 seconds, and if he has the net connection intact, then we shall also be able to inform the true owner about the intrusion with the help of an e-mail. In proposed system we are detecting the intrusion through many thing like integrity, checking currently running processes, by key log, etc. These all activities are performed by user. The first activity is file integrity. We are detecting intrusion through file integrity. In file integrity concept if any user delete the file or modify file or insert file into specific directory then by Using our system we can detect it. If any file delete or modify of insert into specific folder then that file will save in folder which is specified by client. Then file integrity log send to server. Server send the integrity of that file to the clients email id. So that client will easily know which file is modified. So that that we can recover that modified file from specified backup folder.

International Journal of Innovative Research in Computer and Communication Engineering

(An ISO 3297: 2007 Certified Organization)

Website: www.ijirccce.com

Vol. 5, Issue 10, October 2017

B. Flow of System:

This system can be used to detect the host intrusion detection where host machine comprises the confidential files. Attackers can attack on host machine that attacks would be detect by the system and updated files can be recovered by system. This system can detect the files modification and also prevent the file modification. If files deleted from the host machine permanently then system cant recovered the files.

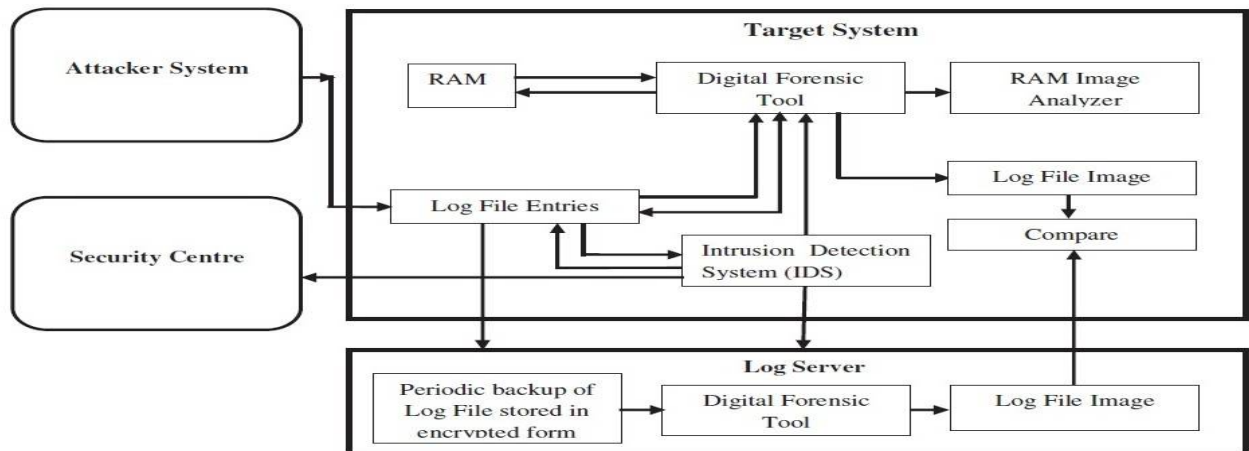

Fig. 2. Flow of System

C. Algorithms:

Input: U's log file where U is user of the host machine.

- Output: U's habit file or Attack Detection.
- Procedure:

```

G = |LogFile| - |SlidingWindow|
|SlidingWindow| = |L-Window| = |C-Window|
for(i = 0; i < G-1; i++)
{
for(j = 0; j < G-1; j++)
{
add K grams of L window in L window
add K' grams in current C window
compare K-grams and K' grams with subsequent algorithm.

```

```

if(the identified pattern is already exist in habit file)
increase count of SC- pattern by 1
else
{
Check the pattern in attacker profile
if(Present in profile)
insert SC-pattern into habit file with counter = 1
else
consider as attack.
}
}
}

```



International Journal of Innovative Research in Computer and Communication Engineering

(An ISO 3297: 2007 Certified Organization)

Website: www.ijircce.com

Vol. 5, Issue 10, October 2017

IV. CONCLUSION

In this paper for the identify SC pattern for the user we have use data mining and forensic technique. Most commonly used SC-patterns are filtered out when the time that a habitual SC pattern appears in the user's log file is counted, and then a user's profile is established. By identifying a user's SC-patterns as his/her computer usage habits from the user's current input SCs, the IIDPS resists suspected attackers.

REFERENCES

1. A. Sadeghi, C. Stubble, and M. Winandy, "Compartmented security for browsers—Or how to thwart a phisher with trusted computing," in Proc. IEEE Int. Conf. Avail., Rel. Security, Vienna, Austria, Apr. 2007, pp. 120–127.
2. C. Yue and H. Wang, "BogusBiter: A transparent protection against phishing attacks," ACM Trans. Int. Technol., vol. 10, no. 2, pp. 1–31, May 2010.
3. Q. Chen, S. Abdelwahed, and A. Erradi, "A model-based approach to self-protection in computing system," in Proc. ACM Cloud Autonomic Comput. Conf., Miami, FL, USA, 2013, pp. 1–10.
4. F. Y. Leu, M. C. Li, J. C. Lin, and C. T. Yang, "Detection workload in a dynamic grid-based intrusion detection environment," J. Parallel Distrib. Comput. vol. 68, no. 4, pp. 427–442, Apr. 2008.
5. H. Lu, B. Zhao, X. Wang, and J. Su, "DiffSig: Resource differentiation based malware behavioral concise signature generation," Inf. Commun. Technol., vol. 7804, pp. 271–284, 2013.
6. Z. Shan, X. Wang, T. Chiueh, and X. Meng, "Safe side effects commitment for OS-level virtualization," in Proc. ACM Int. Conf. Autonomic Comput., Karlsruhe, Germany, 2011, pp. 111–120.
7. M. K. Rogers and K. Seigfried, "The future of computer forensics: A needs analysis survey," Comput. Security, vol. 23, no. 1, pp.12–16, Feb. 2004.
8. J. Choi, C. Choi, B. Ko, D. Choi, and P. Kim, "Detecting web based DDoS attack using MapReduce operations in cloud computing environment," J. Internet Serv. Inf. Security, vol. 3, no. 3/4, pp. 28–37, Nov. 2013.
9. Q. Wang, L. Vu, K. Nahrstedt, and H. Khurana, "MIS: Malicious nodes identification scheme in network-coding-based peer-to-peer streaming," in Proc. IEEE INFOCOM, San Diego, CA, USA, 2010, pp. 1–5.
10. Z. A. Baig, "Pattern recognition for detecting distributed node exhaustion attacks in wireless sensor networks," Comput. Commun., vol. 34, no. 3, pp. 468–484, Mar. 2011.
11. H. S. Kang and S. R. Kim, "A new logging-based IP traceback approach using data mining techniques," J. Internet Serv. Inf. Security, vol. 3, no. 3/4, pp. 72–80, Nov. 2013.
12. K. A. Garcia, R. Monroy, L. A. Trejo, and C. Mex-Perera, "Analyzing log files for postmortem intrusion detection," IEEE Trans. Syst., Man, Cybern., Part C: Appl. Rev., vol. 42, no. 6, pp. 1690–1704, Nov. 2012.
13. M. A. Qadeer, M. Zahid, A. Iqbal, and M. R. Siddiqui, "Network traffic analysis and intrusion detection using packet sniffer," in Proc. Int. Conf. Commun. Softw. Netw., Singapore, 2010, pp. 313–317.
14. S. O'Shaughnessy and G. Gray, "Development and evaluation of a data set generator tool for generating synthetic log files containing computer attack signatures," Int. J. Ambient Comput. Intell., vol. 3, no. 2, pp. 64–76, Apr. 2011.
15. X. Bao and R. Roy Choudhury. Movi: mobile phone based video highlights viacollaborative sensing. In Proceedings of ACM MobiSys, pages 357370, 2010.