



# Performance of Iterative Receiver for Different Modulation Schemes in OWC

K.R.Prasad Babu<sup>1</sup>, D.Gowri Sankar Reddy<sup>2</sup>

M.Tech Student [CS], Dept. of ECE, SVU College of Engineering, Tirupathi, Andhra Pradesh, India<sup>[1]</sup>

Assistant Professor, Dept. of ECE, SVU College of Engineering, Tirupathi, Andhra Pradesh, India<sup>[2]</sup>

**ABSTRACT:** Now a day's rapidly growing demand for high data rate in wireless communications applications and the significant increase of the number of users, the radiofrequency (RF) spectrum become one of the rare resources in the world. To extract non negative signals in optical wireless communication (OWC) systems, flipped orthogonal frequency division multiplexing (Flip-OFDM) transmits positive and negative parts of the signal more than two back to back OFDM subframes (positive sub frame and negative subframe, individually). As the conventional receiver for Flip-OFDM transmit the data by subtracting the negative frame from the positive subframe. Then the signal analysis shows that the information will be transmitted by both the subframes. But in conventional the data loss will be there. To overcome this problem we are proposed an iterative receiver to increase the performance of FLIP-OFDM by abusing the signal in two frames. The performance results are verified with 16-QAM and 16-PSK at the initial step of OFDM transmitter. So our simulation results show that the proposed iterative receiver provides significant bit error rate (BER) compare to conventional receiver.

**KEYWORDS:** Iterative receiver; Flip-OFDM; Optical wireless communication (OWC).

## I. INTRODUCTION

With the widespread organization of light deployment diodes (LEDs), optical wireless communication (OWC) has pulled an increasing interest in educated community and industry recently [1]. Because of its distinct advantages such as rich spectrum resources and high security purpose, OWC has replaces attractive alternate to radio frequency (RF) systems[2]. To accomplish high symbol rates and mitigate inter-symbol interference (ISI), orthogonal frequency division multiplexing (OFDM) has been utilized in OWC [3] – [5]. Since intensity modulation and direct detection (IM/DD) is continuously utilized as a part of OWC frameworks, the transmitted signals must be real and nonnegative. To resolve the issue of bipolarity in OFDM signals, a few OFDM methods have been proposed for OWC. They are direct current (DC) optical OFDM (DCO-OFDM) [6], asymmetrically clipped optical OFDM (ACO-OFDM) [7], along with pulse-amplitude-modulated discrete multi tone (PAM-DMT) [8].

DCO-OFDM adds a DC level to the OFDM symbols, This increases the power dissipation of the signal significantly. ACO-OFDM and PAM-DMT have no need of DC bias due to clipping operation, yet each has only half the spectral efficiency of DCO-OFDM. The authors in [9] introduced a novel OFDM procedure named as Flip-OFDM in which positive and negative parts of the signals are separately transmitted two consecutive OFDM subframes. In [10], authors demonstrated that Flip-OFDM can be modified to approach the spectral efficiency of DCO-OFDM with no biasing, it contributes to the practical applications of Flip-OFDM in OWC.

In the conventional receiver for Flip-OFDM, the information is recovered by subtracting the negative signal frame from the positive signal frame [9]. This procedure is basic and straightforward. In any case, it expands the noise variance of the receiver symbols, making the performance much worse than that of bipolar OFDM with the same modulation scheme. To enhance the performance of Flip-OFDM, a time-domain noise filtering technique was introduced in [11] and investigated in [12]. Of course, the algorithm does not make full utilization of the signal structures. Here in this letter, an iterative receiver is proposed for Flip- OFDM by completely exploiting the structures of the received signals. Simulations confirm that the proposed iterative receiver is superior to different receivers.

# International Journal of Innovative Research in Computer and Communication Engineering

(An ISO 3297: 2007 Certified Organization)

Vol. 4, Issue 10, October 2016

## II. RELATED WORK

### A. ORTHOGONALITY OF OFDM

In communication model of the orthogonal frequency division multiplexing (OFDM), used sub carriers are orthogonal to each other. The Orthogonality helpful in preventing the overlapping between the sub carriers in the respective nature of frequency domain. The accuracy of communication model is simply based on how effectively utilizes the bandwidth and this is technically named as spectral efficiency or bandwidth efficiency, the utilized bandwidth efficiency is free of Inter carrier interference and also the absence of Inter carrier interference (ICI) is mainly due to usage of Orthogonality in orthogonal frequency division multiplexing.

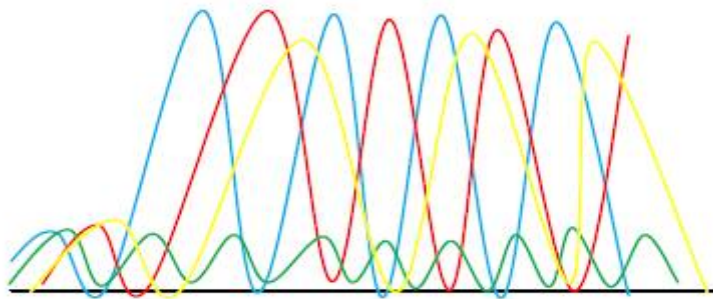

Fig.1. Orthogonality in orthogonal frequency division multiplexing (OFDM)

### B. FLIP-OFDM SYSTEM

The Flip-OFDM block diagram is shown in figure 2. The input random signal symbol rate streams (high) are converted into symbol rate streams (low). The important thing in the OFDM block diagram is the modulation scheme which modulates the low symbol rate streams in parallel way and this parallel stream given input to the IFFT block which transforms the frequency domain to time domain before it reaches the channel. Adding the cyclic prefix acts as the guard band and the reverse of transmission is accomplished at the receiver end.

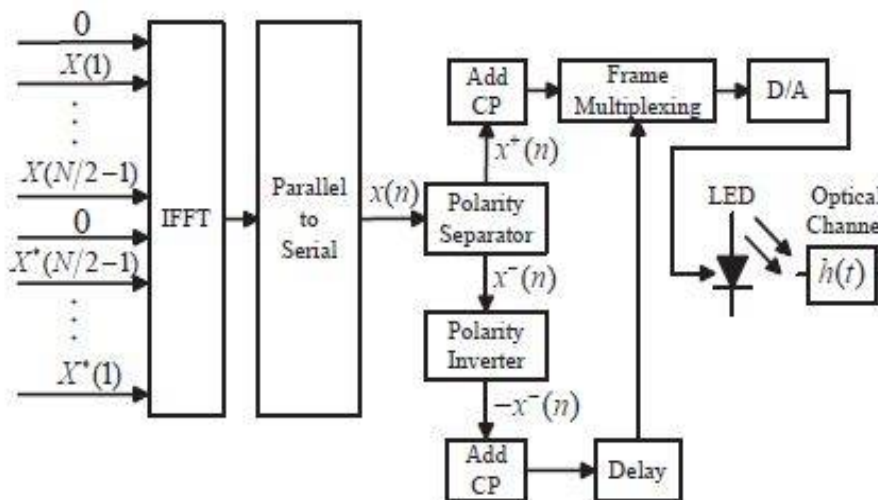

Fig.2. Block diagram of Flip-OFDM Transmitter



# International Journal of Innovative Research in Computer and Communication Engineering

(An ISO 3297: 2007 Certified Organization)

Vol. 4, Issue 10, October 2016

## III. RECEIVER DESIGN

### A. CONVENTIONAL RECEIVER

Let us consider the one random signal for this we can apply the modulation scheme then we will get the frequency domain signal, This can be applied to the inverse FFT we get the signal  $x(n)$  which is real and bipolar, this can be decomposed as positive part signal  $x^+(n)$  and negative part signal  $x^-(n)$ , i.e.,

$$x(n) = x^+(n) + x^-(n),$$

where,

$$x^+(n) = \begin{cases} x(n), & x(n) \geq 0 \\ 0, & x(n) < 0 \end{cases}$$

$$x^-(n) = \begin{cases} x(n), & x(n) < 0 \\ 0, & x(n) \geq 0 \end{cases}$$

After this we can add the cp and transmit in the channel finally we can get the received signal vectors in the frequency domain are given as

$$\begin{aligned} Y^+ &= H X^+ + Z^+ \\ Y^- &= -H X^- + Z^- \end{aligned}$$

Where,

$$X^+ = W_N x^+, \quad X^- = W_N x^-$$

In conventional receiver subtracts the negative subframe from the positive sub frame to decode the data, So

$$\begin{aligned} Y^+ - Y^- &= H X^+ + H X^- + Z^+ - Z^- \\ &= H X + Z \end{aligned}$$

Finally the conventional receiver can be described as

$$X_{\text{conv}} = \text{dec}[H^{-1} Y^+ - H^{-1} Y^-]$$

### B. PROPOSED RECEIVER

The conventional receiver is basic and straightforward, but it doesn't fully exploit the structures of the received signals. Now in this paper we are performed iterations. If the number of iterations increases then bit error rate going to be decreases. So in our proposed receiver we don't take the positive and negative parts of the signals directly, we have to make some modifications as shown below and establishing the relationship between the two received signals  $Y^+$ ,  $Y^-$  and the input data  $X$ .

In this receiver let us consider  $|x|$  can be denoted as

$$|x| = S(X) \quad x = S(X) W_N^H X,$$

Where  $S(X)$  is expressed as

$$S(X) = \text{diag} \{ \text{sign}(x) \} = \text{diag} \{ \text{sign}(W_N^H X) \}$$

From this the positive and negative parts of the signal can be written as follows,

# International Journal of Innovative Research in Computer and Communication Engineering

(An ISO 3297: 2007 Certified Organization)

Vol. 4, Issue 10, October 2016

$$x^+ = \frac{x + |x|}{2} = \frac{x + S(X)W_N^H X}{2}$$

$$x^- = \frac{x - |x|}{2} = \frac{x - S(X)W_N^H X}{2}$$

From this the relationship between the  $Y^+$  and  $X$  can be derived as

$$Y^+ = \frac{H + HW_N S(X)W_N^H}{2} X + Z^+$$

So finally the iterative receiver becomes

$$X^i_{LOS} = dec[Y^+ - Y^-], i = 0$$

$$X^i_{LOS} = dec\left\{\frac{1}{2}[I + W_N S(X_{LOS}^{(i-1)})W_N^H]Y^+ + \frac{1}{2}[W_N S(X_{LOS}^{(i-1)})W_N^H - I]Y^-\right\}, i = 1, 2, \dots, k$$

## IV. SIMULATION RESULTS

Here, our simulation results shows that the bit error rate performance of the conventional receiver and proposed iterative receiver when number of subcarriers are 64, the length of cyclic prefix (CP) is 32. and also results shown for 16-QAM and 16-PSK individually as shown below.

### A. IN THE CASE OF 16-QAM:

In this case we are taking 16-QAM constellation mapping at the basic step of OFDM transmitter. And then we calculate the BER for conventional receiver and iterative receiver by varying the signal to noise ratio. Our simulation results shown in Fig.3 is bit error rate curves for two different receivers from the figure red colour line indicates that bit error rate curve for conventional receiver and black colour line indicates that bit error rate curve for iterative receiver.

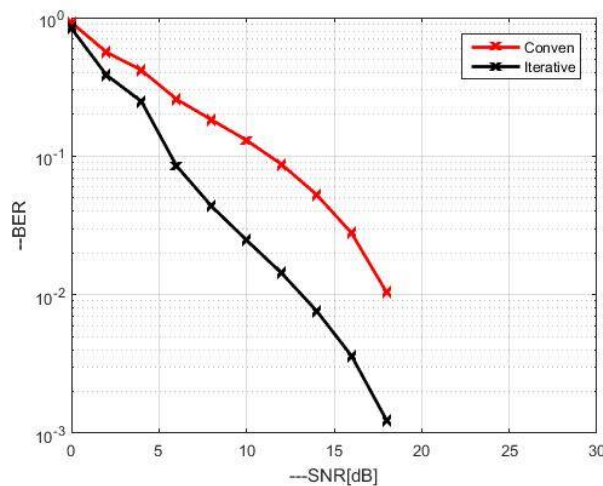

Fig.3.bit error rate comparison for different receivers

# International Journal of Innovative Research in Computer and Communication Engineering

(An ISO 3297: 2007 Certified Organization)

Vol. 4, Issue 10, October 2016

From the simulation results we can tabulate the values as shown in Table.1. for the signal to noise ratio variation from 2 dB to 18 dB, And also we can tabulate the improvement factor in bit error rate from the difference of conventional and iterative receivers bit error rates.

SNR[dB]	Conventional Receiver BER	Iterative receiver BER	Improvement Factor in BER
2	0.5634	0.3848	0.1786
4	0.4169	0.2481	0.1688
6	0.2576	0.08509	0.17251
10	0.1303	0.02477	0.1055
14	0.05278	0.007645	0.04513
18	0.01037	0.001237	0.00913

Table.1. bit error rate values for different receivers and improvement factor

## B. IN THE CASE OF 16-PSK:

In this case we are taking 16-PSK constellation mapping at the basic step of OFDM transmitter. And then we calculate the BER for conventional receiver and iterative receiver by varying the signal to noise ratio. Our simulation results shown in Fig.4 is bit error rate curves for two different receivers, from the figure red colour line indicates that bit error rate curve for conventional receiver and black colour line indicates that bit error rate curve for iterative receiver.

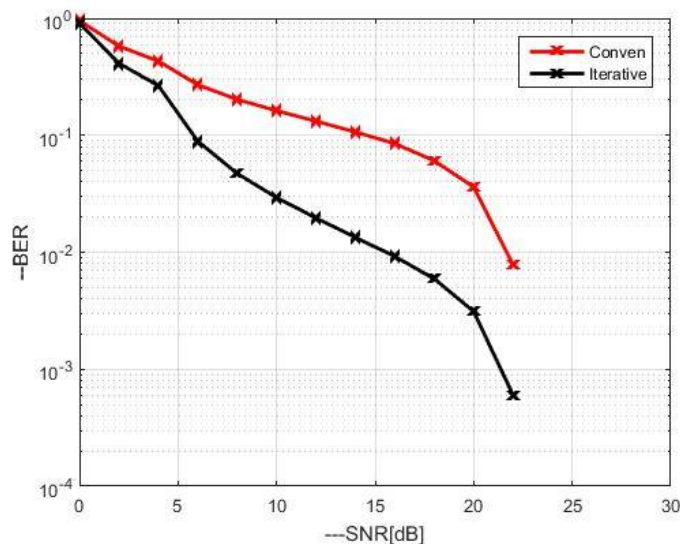

Fig.4.bit error rate comparison for different receivers

From the simulation results we can tabulate the values as shown in Table.2. for the signal to noise ratio variation from 2 dB to 18 dB, And also we can tabulate the improvement factor in bit error rate from the difference of conventional and iterative receivers bit error rates.

# International Journal of Innovative Research in Computer and Communication Engineering

(An ISO 3297: 2007 Certified Organization)

Vol. 4, Issue 10, October 2016

SNR[dB]	Conventional Receiver BER	Iterative receiver BER	Improvement Factor in BER
2	0.5781	0.4121	0.166
4	0.4306	0.2659	0.1647
6	0.2702	0.08908	0.1811
10	0.1621	0.02933	0.13277
14	0.1066	0.01339	0.09321
18	0.06058	0.005926	0.05465

Table.2. bit error rate values for different receivers and improvement factor

## V. RESULTS COMPARISON

From the simulation results shown above, we can compare the results by considering the improvement factor, let us consider the two modulation schemes the improvement factor can be compared as for lower signal to noise ratio values and higher signal to noise ratio values, i.e.,

For lower values of signal to noise ratio, for example say SNR= 2dB, Then

Modulation Scheme	Conventional receiver BER	Iterative receiver BER	Improvement factor in BER
<b>16-QAM</b>	0.5634	0.3848	<b>0.1786</b>
16-PSK	0.5781	0.4121	0.166

Table.3. bit error rate values for different receivers and improvement factor for lower SNR values

For higher values of signal to noise ratio, for example say SNR= 18dB, Then

Modulation Scheme	Conventional receiver BER	Iterative receiver BER	Improvement factor in BER
16-QAM	0.01037	0.001237	0.00913
<b>16-PSK</b>	0.06058	0.005926	<b>0.05465</b>

Table.4. bit error rate values for different receivers and improvement factor for higher SNR values

From the comparison we can say that based on signal power we can say that which modulation scheme is better than other. i.e. If the signal power or in other words signal to noise ratio is less then we go for 16-QAM scheme for better performance of the receiver, else signal power or in other words signal to noise ratio is high then we go for 16-PSK scheme for better performance of the receiver. Where ever we have low signal power applications better to go with 16-QAM scheme and where ever we have high power applications better to go with 16-PSK scheme.

If we compare the bit error rate for two different receivers whatever be the modulation scheme the iterative receiver is better than that of conventional receivers.

## VI. CONCLUSION AND FUTURE SCOPE

From the two modulation schemes for the same signal power and same constellation symbols QAM is better than PSK but its may not true in all the cases. From this paper we can conclude that for the same constellation symbols of two modulation schemes, If the signal power is less in that case QAM is better else if the signal power is high in that case PSK is better in the proposed iterative receiver design. At medium signal power cases we can go for any modulation. So in any modulation scheme either 16-QAM or 16-PSK the iterative receiver gives significant bit error rate than that of conventional receiver. Finally the proposed iterative receiver can also be connected to the modified Flip-OFDM framework proposed [10] and the multiple-input multiple output (MIMO) framework proposed in [16].



# International Journal of Innovative Research in Computer and Communication Engineering

(An ISO 3297: 2007 Certified Organization)

Vol. 4, Issue 10, October 2016

## REFERENCES

1. H.L. Minh, D. O'Brin, G. Faulkner, L. Zeng, K. Lee, D. Jung, Y. Oh, and E. T. Won, "100-mb/s NRZ visible light communications using a postequalized white led," IEEE photonics Technology Letters, vol. 21, no. 15, pp. 1063-1065, Aug, 2009.
2. J.-B. Wang, Q.-S. Hu, J. Wang, M. Chn, and J.-Y. Wang, "Tight bounds on channel capacity for dimmable visible light communications," Journal of Light wave Technology, vol. 31, no. 23, pp. 3771-3779, Dec, 2013.
3. J. Armstrong, "OFDM for optical communications," Journal of Light wave Technology, vol. 27, no. 3, pp. 189-204, Feb, 2009.
4. D. J. Baros, S. K. Wilson, and J. M. Kahn, "Comparison of orthogonal frequency-division multiplexing and pulse-amplitude modulation in indoor optical wireless links," IEEE Transactions on Communications, vol. 60, no. 1, pp. 153-163, Jan. 2012.
5. N. Hung, J.-B. Wang, J. Wang, C. Pan, H. Wang, and M. Chn, "Receiver design for PAMDMT in indor optical wireless links," IEEE Photonics Technology Letters, vol. 27, no. 2, pp. 161-164, Jan. 2015.
6. J. Armstrong and B. Schmidt, "Comparisn of asymetrically clipped optical OFDM and DC biased optical OFDM in AWGN," IEEE Communicatins Letters, vol. 12, no. 5, pp. 343-345, May 2008.
7. J. Armstrong and A. Lowey, "Power efficient optical OFDM," Electronics Letters, vol. 42, no. 6, pp. 370-372, Mar. 2006.
8. S. C. J. Lee, S. Randel, F. Bryer, and A. M. Koonen, "PAM-DMT for intensity-modulated and direct detction optical communication systems," IEEE Photonics Technology Letters, vol. 21, no. 23, pp. 1749-1751, Dec. 2009.
9. N. Fernando, Y. Hong, and E. Viterbo, "Flip- OFDM for optical wireless communications," in Proc. IEEE Information Theory Workshop (ITW), pp. 5-9, 2011.
10. D. Tsonev and H. Has, "Avoiding spectral efficiency los in unipolar OFDM for optical wireless communication," in Proc. IEEE International Conference on Communications (ICC), pp. 3336-3341, 2014.
11. N. Fernando, Y. Hong, and E. Vitrobo, "Flip- OFDM for unipolar communication systems," IEEE Transactions on Communicatons, vol. 60, no. 12, pp. 3726-3733, Dec, 2012.
12. D. Tsonev, S. Sinaovic, and H. Haas, "Novel unipolar orthogonal frequency divison multiplxing (U-OFDM) for optical wireless," in Proc. IEEE 75th Vehicular Technology Conference (VTC Spring), pp. 1-5, 2012.
13. E. G. Larson, "MIMO detection metods: How they work," IEEE Signal Processing Magazine, vol. 26, no. 3, pp. 91-95, May 2009.
14. J. Karout, E. Agrel, K. Szczerba, and M. Karlson, "Optimizing constellations for single subcarrier intensity modulated optical systems," IEEE Transactions on Information Theory, vol. 58, no. 7, pp. 4645-4659, July, 2012.
15. J. R. Barry, J. M. Kan, W. J. Krause, E. A. Lee, and D. G. Meserschmitt, "Simulation of mlti path impulse response for indor wireless optical channels," IEEE Journal on Selected Areas in Communications, vol. 11, no. 3, pp. 367-379, Apr, 1993.
16. L. Wu, Z. Zhng, and H. Liu, "MIMO-OFDM visible light communications system with low complexity," in Proc. IEEE International Conference on Communications (ICC), pp. 3933-3937, 2013.

## BIOGRAPHY

**Mr. K.R.Prasad Babu** is currently doing M.Tech in the stream of communication systems at the Department of Electronics and Communication Engineering at Sri Venkateswara University College of Engineering (SVUCE), Tirupathi, Andhra Pradesh, India.

**Mr. D.Gowri Sankar Reddy** is currently a assistant professor of Sri Venkateswara University College of Engineering (SVUCE), Tirupathi, Andhra Pradesh, India. He has 10 years of teaching experience.