



ISSN(Online): 2320-9801  
ISSN (Print): 2320-9798

# International Journal of Innovative Research in Computer and Communication Engineering

(An ISO 3297: 2007 Certified Organization)

Website: [www.ijircce.com](http://www.ijircce.com)

Vol. 5, Issue 4, April 2017

## Flood Alert Management System Using IoT and Microcontroller

M.Madhumathi, R.Kingsy Grace

PG Scholar, Dept. of Computer Science and Engineering, Sri Ramakrishna Engineering College, Coimbatore, India

Associate Professor, Dept. of Computer Science and Engineering, Sri Ramakrishna Engineering College,

Coimbatore, India

**ABSTRACT:** Reservoir is the best infrastructures for save the water resources and has to play more roles in flood control. Flood limiting water level (FLWL) is an effective and value approach to provide safeguards the people from flood caused suddenly without any intimation. The proposed system acts as an alert to people when the water level increases from the normal capacity. Advanced sensors are used to identify the level of water presented in dams, lakes and heavy water storage areas. Flood observatory system is a system which consists of a microcontroller unit–ATMEGA328P, Ultrasonic sensor, Water level sensor, HC-05 Bluetooth, RS-232 USB to TTL Cable, 12V DC Motor and LCD to display when the water level will have increase or decrease values. During the abnormal water level condition of the reservoir, the proposed system automatically switches ON the shutter and releases the excess water. Ultrasonic sensor and Water level sensor are used to monitor the flood level conditions. The Flood Observatory System is fully automated device which is capable of operating without human intervention at any time regardless of the location being installed.

**KEYWORDS:** Flood limited water level (FLWL), Microcontroller, Ultrasonic sensor.

### I. INTRODUCTION

Flood is the biggest natural disaster happens in worldwide without prior warning. Floods will damage the crops, cars, buildings, homes and anyone in their path. Reservoir is the most efficient tool to save the water resource; Reservoirs are serving for different purposes in spatial and temporal method such as a hydropower generation, flood control, navigation, ecology and recreation. The flood-limited water level (FLWL), is the parameter to manage between the flood control and conservation, from that the annual maximum value is determined. It is done mainly according to design flood estimation flood series, while it neglects seasonal flood information. FLWL is mainly determined by reservoir regulation using the annual design flood or annual design storm. The reservoir water levels are not allowed to generally exceed FLWL during flood season; it should be provide adequate storage for flood prevention. Many investigators have drawn the scrutiny between the flood control and conservation for reservoir operation. The two effective approaches for flood control are Multiple duration limited water level (or seasonal FLWL) and dynamic limited water level due to increase water storage level of a reservoir. Two types of operation in flood control that takes place, FLWL is too high due to developing the conservation profit and FLWL is too low due to upgrade flood obstacle capacity. To overestimate the supply water volume or hydropower generation from a conservation profit standpoint and it is used to maximize the flood control volume during a flood safety standpoint. Therefore, a reasonable dynamic control of FLWL or upper limitation of seasonal FLWL must be estimated in advance at the planning and designing stages. Flood control analyzed four uncertainties that is hydrological, hydraulic, time-delay uncertainty and stage-storage uncertainty, and also probability distributions. The univariate probability study is analyzed for flood frequency which will lead to an over – or underestimation of the risk analysis. This study also deals with the design of flood control systems using copulas.



# International Journal of Innovative Research in Computer and Communication Engineering

(An ISO 3297: 2007 Certified Organization)

Website: [www.ijircce.com](http://www.ijircce.com)

Vol. 5, Issue 4, April 2017

## II. LITERATURE SURVEY

[1] Flood Control Operation Mode with forecast information (FCOMFI) is an important base for risk analysis of the reservoirs. DIAO YanFang & WANG BenDe have analyzed the four uncertainties that is hydraulic, hydrological, stage-storage uncertainty and time-delay uncertainty, and also their probability distributions. This proposed model was estimate by Monte Carlo simulation, based on Latin hypercube sampling. The major potential risks are includes in two methods i. Risk of reservoir ii. Risk of lower reach. Monte Carlo simulation is a statistical sampling technique that generates random variables that preserve the distributional properties and provide numerical evaluations of the probabilistic features of the system response. The risk analysis of FCOMFI aims at the safety of the reservoir and the effective utilization of the flood water resources.

[2] Flood control, which may be equally important in semi-arid areas, correspond to two different reservoir water levels. The first is the limited water level it can be used for flood control. There are two approaches are proposed by Ruan Yun, Vijay P. Singh, one is multiple duration limited water level and second is dynamic limited water level. This paper also proposed a dynamic limited water level for flood control build on conditional probabilities of large storms. This means that the annual limited water level for the flood season can be modified by the several multiple duration limited water levels such as monthly duration limited water levels or weekly duration limited water levels.

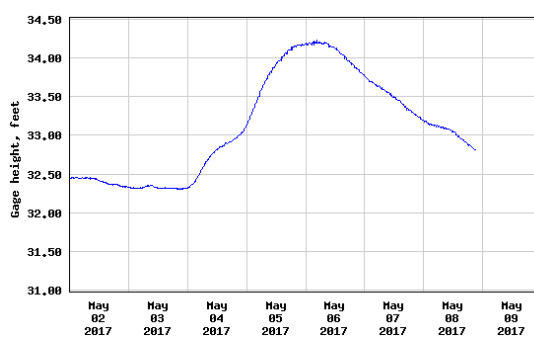

Fig.1(a). Survey for Flood Level based on Year

[3] Flood disaster mitigation based on a comprehensive assessment of the flood risk. “German Research Network Natural Disasters” project, the working group on “Flood Risk Analysis” searching complete flood disaster chain from the triggering event down to its various consequences. The “Flood Risk Analysis” group developed complex, spatially distributed models. It represent the relevant hydrological, hydraulic, meteorological, geo-technical, and socio-economic processes. The flood disaster chain represents the two way approaches (simple probabilistic and complex deterministic). This approach allows the various number of simulation runs in a Monte Carlo framework and provides the support for a probabilistic risk assessment. The proposed model is useful to integrated assessment of flood risk in flood prone area. Applying this concept, it is the most important failure mechanism for new river levees. The breach criterion is scope as the difference between the actual overflow and the critical overflow. All modules are combined in a Monte Carlo framework. First, a discharge value was randomly chosen from the composite flood frequency. Second flood type was randomly chosen.

[4] The risk analysis of a flood control system is presenting a method, to estimate the probability of generated hydrological scenarios. Using copulas bivariate probability analyses of different flood variables are applied univariate probability to overcome that analysis may lead to an over- or underestimation of the hydrological risk. Which consists of two reservoirs located downstream of the main tributaries and flood polders. The joint probability of the inflow peaks at the two reservoirs are analysed the spatial distribution of flood events within the river basin. Risk analysis of the individual flood detention structures are use in second application copulas.

## III. PROPOSED METHOD

The main concept of the proposed work is to alert during flood for protecting the people from flood caused suddenly without any intimation. The Flood Observatory System is designed to be an intelligent system for monitoring

# International Journal of Innovative Research in Computer and Communication Engineering

(An ISO 3297: 2007 Certified Organization)

Website: [www.ijircce.com](http://www.ijircce.com)

Vol. 5, Issue 4, April 2017

flood at remote locations which has a high frequency of flooding. The Flood Observatory System is fully automated device which is capable of operating without human intervention at all time regardless of the location being installed. Some of the features of the Flood Observatory System are very helpful for the monitoring station in assisting the monitoring station management when there is flood at the measured location. This self operated system enables the monitoring station to be informed on the water level changes at a certain location on real time basis. The system architecture diagram is shown in Figure 1.

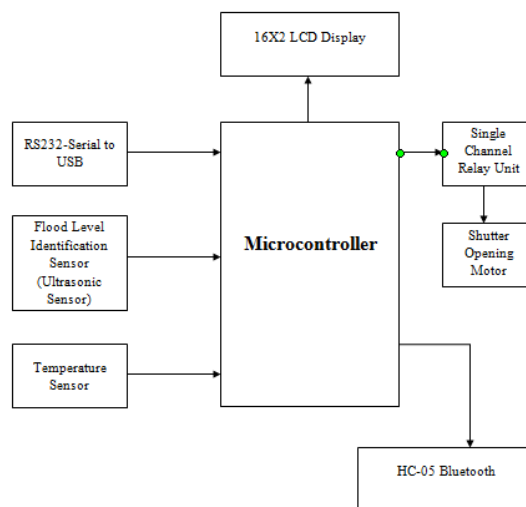

Fig1(b).System Architecture Diagram

## 1. Hardware Description

### a. Microcontroller ATMEGA328

It is a microcontroller board based on ATMEGA328. The Uno comes programmed with a bootloader for uploading a new code without the use of an external hardware program. It consist of a 16MHz ceramic resonator,6analog inputs, 14 digital input/output pins,a USB connection,a power jack,a reset button and an ICSP header.It contains everything needed to support the microcontroller.By connecting the controller to a computer with a USB cable or power it with an adapter or battery to get started.Figure 2 shows the image for Arduino UNO microcontroller.

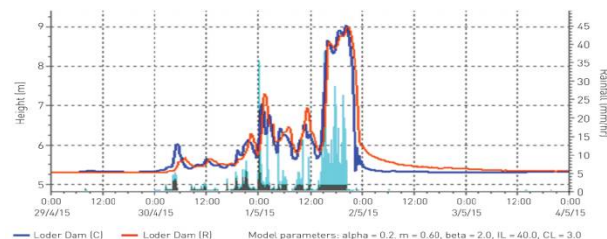

Fig.1(c). Rainfall Level Vs. Dam Water Level

# International Journal of Innovative Research in Computer and Communication Engineering

(An ISO 3297: 2007 Certified Organization)

Website: [www.ijircce.com](http://www.ijircce.com)

Vol. 5, Issue 4, April 2017

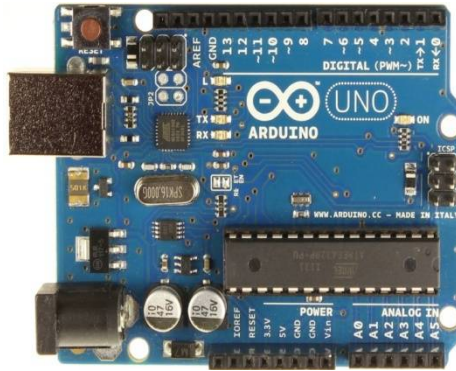

Fig 2:Image for Arduino Uno microcontroller

## b. Ultrasonic sensor

Ultrasonic ranging module HC - SR04 provides 2cm - 400cm non-contact measurement function, the ranging accuracy can reach to 3mm. The modules includes ultrasonic transmitters, receiver and control circuit. The basic principle of work Using IO trigger for at least 10us high level signal. The Module automatically sends eight 40 kHz and detect whether there is pulse signal back. IF the signal back, through high level , time of high output IO duration is the time from sending ultrasonic to returning. Test distance = (high level time× velocity of sound (340M/S) / 2. Figure 3 shows the image for Ultrasonic sensor.



Fig3:Ultrasonic sensor

## c. Waterlevelsensor

Level sensors detect the level of liquids and other fluids and fluidized solids. The level measurement can be either continuous or point values. Continuous level sensors measure level within a specified range and determine the exact amount of substance in a certain place, while point-level sensors only indicate whether the substance is above or below the sensing point. Generally the latter detect levels that are excessively high or low. Figure 4 shows the image for water level sensor.



Fig4:waterlevel sensor

# International Journal of Innovative Research in Computer and Communication Engineering

(An ISO 3297: 2007 Certified Organization)

Website: [www.ijircce.com](http://www.ijircce.com)

Vol. 5, Issue 4, April 2017

## d. Bluetooth

HC-06 is a class-2 bluetooth module with Serial Port Profile, which can configure as either Master or slave. a Drop-in replacement for wired serial connections, transparent usage. You can use it simply for a serial port replacement to establish connection between MCU, PC to your embedded project and etc. Figure 5 shows the image for Bluetooth.

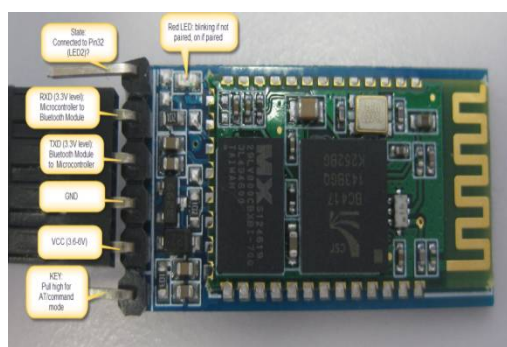

Fig5:Image for Bluetooth

## e. LCD Display

LCD (Liquid Crystal Display) screen is an electronic display module and find a wide range of applications. A 16x2 LCD display is very basic module and is very commonly used in various devices and circuits. These modules are preferred over seven segments and other multi segment LEDs. The reasons being: LCDs are economical; easily programmable; A 16x2 LCD means it can display 16 characters per line and there are 2 such lines. In this LCD each character is displayed in 5x7 pixel matrix. This LCD has two registers, namely, Command and Data. The ASCII value of the character to be displayed on the LCD can be stored by using Data register. Figure 6 shows the image for LCD Display.



Fig6: Image for LCD Display

## 2. Software description

The Arduino integrated development environment (IDE) is a cross platform application written in Java, and derives from the IDE for the Processing programming language and the Wiring projects. It is designed to introduce programming to artists and other newcomers unfamiliar with software development. It includes a code editor with features such as syntax highlighting, brace matching, and automatic indentation, and is also capable of compiling and uploading programs to the board with a single click. A program or code written for Arduino is called a *sketch*. Arduino programs are written in C or C++. The Arduino IDE comes with a software library called "Wiring" from the original Wiring project, which makes many common input/output operations much easier. Users only need define two functions to make a runnable cyclic executive program.

## IV EXPERIMENTAL RESULT:

The water sensor which is inserted in the water and the real time water value is compared with the threshold value (for example 175) by interfacing it with the microcontroller. Ultrasonic sensor is used to the motor is on or off. When the water level was increased the shutter was opened, and when the water level was decreased, the water shutter will be



# International Journal of Innovative Research in Computer and Communication Engineering

(An ISO 3297: 2007 Certified Organization)

Website: [www.ijircce.com](http://www.ijircce.com)

Vol. 5, Issue 4, April 2017

closed. To check the status of the water level and motor status on mobile via SMS. Figure 8 to 12 shows the images of implementation results.

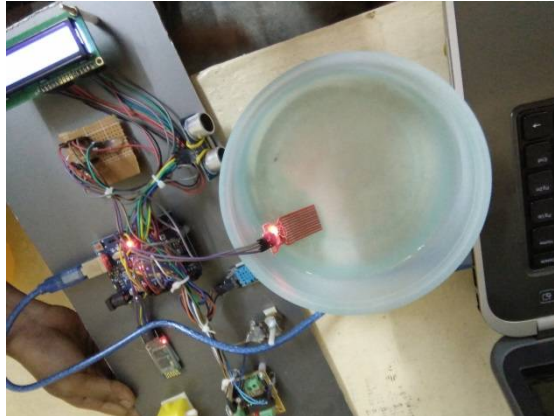

Fig7: Water level sensor is interfaced in the microcontroller

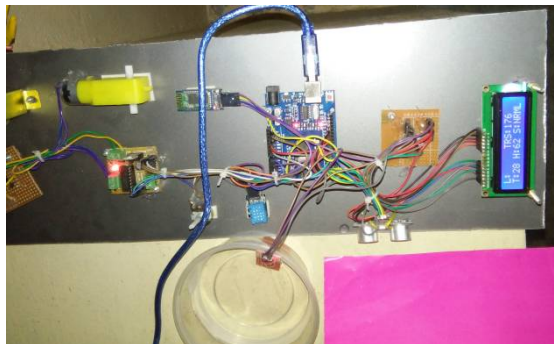

Fig8: Threshold value is set



Fig9: At critical stage shutter is opened.

# International Journal of Innovative Research in Computer and Communication Engineering

(An ISO 3297: 2007 Certified Organization)

Website: [www.ijircce.com](http://www.ijircce.com)

Vol. 5, Issue 4, April 2017

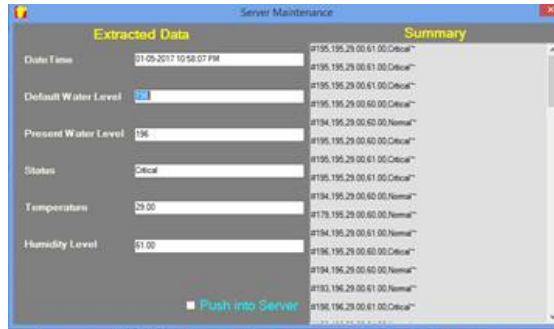

Fig 10 :Screenshot for critical stage

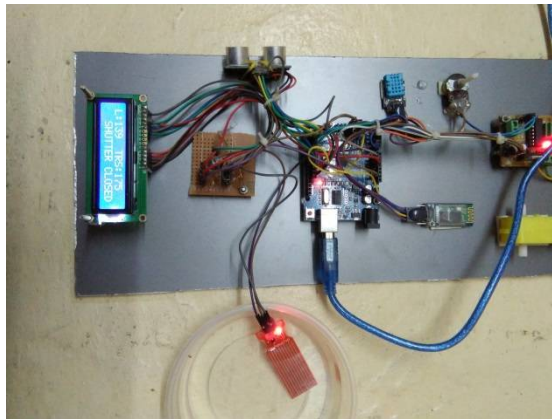

Fig11: At normal stage shutteris closed

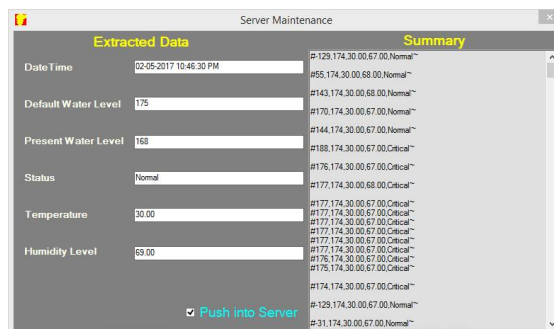

Fig12: Screenshot for normal stage

## V CONCLUSION

The smart water management system is built to reduce the human work and also to save the people. Monitoring the water level conditions will help to alert the authorities via SMS. The user able to get a notification via SMS and do necessary precautions.

The future work of the proposed system is to check the water level in dam. To analysis the risk, calculate the hydrological, hydraulic and reservoir volume. Hydraulic level is increases or decreases SMS will be passed through mobile phone authorities for further action.



ISSN(Online): 2320-9801

ISSN (Print): 2320-9798

# International Journal of Innovative Research in Computer and Communication Engineering

(An ISO 3297: 2007 Certified Organization)

Website: [www.ijircce.com](http://www.ijircce.com)

Vol. 5, Issue 4, April 2017

## REFERENCES

- [1] DIAO YanFang& WANG BenDe ,Risk analysis of flood control operation mode with forecast information based on a combination of risk sources.Sci.China Tech. Sci.MAY 2008.
- [2]Ruan Yun, Vijay P. Singh ,2008, Multiple duration limited water level and dynamic limited water level for flood control, with implications on water supply. Journal of Hydrology (2008) 354, 160– 170.
- [3] HEIKO APEL, ANNEGRET H. THIEKEN, BRUNO MERZ andGU` NTER BLO` SCHL,2006, A Probabilistic Modelling System for Assessing Flood Risks. VOL.12,ISSUE 10.
- [4] Bastian Klein, Ph.D.; Markus Pahlow, Ph.D.;YeshewatesfaHundecha, Ph.D.; and Andreas Schumann, 2005,Probability Analysis of Hydrological Loads for the Design of Flood Control Systems Using Copulas.J. Hydrol. Eng, vol.15, No.1
- [5]Yanlai Zhou &Shenglian Guo,2014,Risk analysis for flood control operation of seasonal flood-limited water level incorporating inflow forecasting error. Hydrological Sciences Journal, 59:5, 1006-1019
- [6] Genest, C., Rivest, L.P., 1993. Statistical inference procedures for bivariate Archimedean copulas. J. Am. Stat. Assoc..IEEE SENSORS JOURNALS VOL 2.
- [7] Chen, L., Guo, S.L., Yan, B.W., Liu, P., Fang, B., 2010. A new seasonal design flood method based on bivariate joint distribution of flood magnitude and date of occurrence. Hydrol.Sci.J. International Journal of Engineering Technology and Advanced Engineering volume 2, Issue 7.
- [8] Liu, X.Y., Guo, S.L., Liu, P., Chen, L., Li, X., 2011. Deriving optimal refill rules for multi-purpose reservoir operation. Water Resour. Manag. IEEE SENSORS JOURNAL,VOL.15
- [9] Apel, H., Thieken, A.H., Merz, B., Bloschl, G., 2006. Probabilistic modelling system for assessing flood risks. Vol.6, No. 3
- [10] Yun, R., Cao, S.L., 2004. Model selection of precipitation series extension for Menlou reservoir.J. Shandong Univ. (Eng. Sci.) 34, 96–100 (in Chinese).
- [11] Yue, S., Quarda, T. B. M. J., Bobée, B., Legendre, P., and Bruneau, P.\_2002\_. “Approach for describing statistical properties for flood hydrograph.”*J. Hydrol. Eng.*, 7, 147–153.
- [12] De Michele, C., Salvadori, G., Canossi, M., Petaccia, A., and Rosso, R. \_2005\_.“Bivariate statistical approach to check adequacy of dam spillway.” *J. Hydrol. Eng.*, 10\_1\_, 50–57.