



# International Journal of Innovative Research in Computer and Communication Engineering

(An ISO 3297: 2007 Certified Organization)

Website: [www.ijirccce.com](http://www.ijirccce.com)

Vol. 5, Issue 6, June 2017

## Improving Direct Mapped Cache using Victim Cache

Suyog S. Kandalkar

M.Tech Student, Dept. of Electronics & Communication, DMIETR, Wardha, India

**ABSTRACT:** A CPU is consist of various types of memory. Microprocessor is the first and the leading component of the CPU. With the increasing speed of modern microprocessors, the operating speed of different memories becomes more critical to the system performance. The increasing speed gap between the processors and memories can be matched or adjusted with the help of cache memory. Cache memory are on-chip memory element used to store data. Cache memory is used to increase data transfer rate. The performance of a cache is calculated by its ability of differentiate and maintaining the data that the program will need in near future and unwanted data will be discarded. While using direct mapping technique in cache, there is a fixed cache location for any given block. But due to that two different blocks can map into the same line and the hit ratio will be low. With fully associative mapping, there is flexibility to replace block when a new block read into cache. This paper proposed the technique this technique is very useful to reduce the miss rate in cache memory. In the proposed technique the direct mapped cache is added with a small associative cache known as victim cache. A line removed from the direct mapped is temporarily store in the victim cache.

**KEYWORDS:** Cache memory, Direct mapped cache, Fully Associative cache, Victim cache.

### I. INTRODUCTION

In CPU, cache used by the central processing unit (CPU) of a computer to reduce the average time to access data from the main memory. A cache is a smaller, faster memory, closer to a processor core, which stores copies of the data from frequently used main memory locations. Most CPUs have different independent caches, including instruction and data caches, where the data cache is usually organized as a hierarchy of more cache levels (L1, L2, etc.). When the processor needs to read from or write to a location in main memory, it first checks whether a copy of that data is in the cache. If so, the processor immediately reads from or writes to the cache, which is much faster than reading from or writing to main memory.

Cache memory is used to increase data transfer rate. Generally it is difficult to found data requested by microprocessor in cache memory, as the size of cache memory is very small as compared to RAM and main memory. When any data requested by microprocessor will not found in cache memory this causes cache miss in cache memory. We know that cache memory is on chip memory, if data requested by microprocessor is found in cache memory then it will increase the data transfer rate as data is present nearer to processor. If data requested by microprocessor is not found in cache memory, then data will receive by microprocessor from RAM or main memory. It takes more time for this process and it directly affects the data transfer rate. This means that speed or data transfer rate increase by reducing the cache miss in cache memory.

In design of a cache, parameters that enable design of various cache architectures include the overall cache size, block size and efficiency. The proposed architecture takes advantage of a number of extra victim lines that can be associated with cache sets.

### II. LITERATURE REVIEW

This paper propose the ever increasing density and performance of FPGAs, has increased the importance and popularity of soft processors. The growing gap between the speed of processors and memories can partly be compensated through memory hierarchy. Since memory accesses follow a non-uniform distribution, and vary from one application to



# International Journal of Innovative Research in Computer and Communication Engineering

(An ISO 3297: 2007 Certified Organization)

Website: [www.ijircce.com](http://www.ijircce.com)

Vol. 5, Issue 6, June 2017

another, variable set-associative cache architectures have emerged. In this paper, a novel cache architecture, primarily aimed at soft processors, is proposed to address the variable access demands of applications, through dynamically configurable line-associativity, with no memory overhead. This proposed paper apply their system for increase the speed of the system [1].

This paper proposed the that,Recent trends of CMOS scaling and use of large last level caches (LLCs) have led to significant increase in the leakage energy consumption of LLCs and hence, managing their energy consumption has become extremely important in modern processor design. The conventional cache energy saving techniques require offline profiling or provide only coarse granularity of cache allocation. They present FlexiWay, a cache energy saving technique which uses dynamic cache reconfiguration. FlexiWay logically divides the cache sets into multiple modules and dynamically turns off suitable and possibly different number of cache ways in each module. FlexiWay has very small implementation overhead and it provides fine-grain cache allocation even with caches of typical associativity, e.g. an 8-waycache, this paper proposed the technique for divides the cache sets into multiple [2].

This paper proposed the Customizing caches has until recently been restricted to core-based flows, in which a new chip will be fabricated. However, several configurable cache architectures have been proposed recently for use in pre-fabricated microprocessor platforms. Tuning those caches to a program is still however a cumbersome task left for designers, assisted in part by recent computer-aided design (CAD) tuning aids. They propose to move that CAD on-chip, which can greatly increase the acceptance of configurable caches. They introduce on-chip hardware implementing an efficient cache tuning heuristic that can automatically, transparently, and dynamically tune the cache to an executing program. They carefully designed the heuristic to avoid any cache flushing, since flushing is power and performance costly [3].

This paper proposed the Direct-mapped caches are a popular design choice for high performance processors unfortunately, direct-mapped caches suffer systematic interference misses when more than one address maps into the same cache set. This paper describes the design of column-associative caches. Which minimize the conflicts that arise in direct-mapped accesses by allowing conflicting addresses to dynamically choose alternate hashing functions, so that most of the conflicting data can reside in the cache. At the same time, however, the critical hit access path is unchanged. The key to implementing this scheme efficiently is the addition of a rehash bit to each cache set which indicates whether that set stores data that is referenced by an alternate hashing function. When multiple addresses map into the same location, these rehashed location are preferentially replaced. Using trace-driven simulations and an analytical model, we demonstrate that a column-associative cache removes virtually all interference misses for large caches, without altering the critical hit access time [4].

This appendix looks at two cache strategies mentioned in paper victim cache and selective victim cache. The victim cache approach, proposed by Jouppi [JOUP90], is a strategy designed to combine the fast hit time of direct mapping yet still avoid thrashing. To achieve this objective, the direct-mapped cache is supplemented with a small associative cache known as the victim cache. A line removed from the direct-mapped is temporarily stored in the victim cache, which maintains a small number of lines using a FIFO (first-in-firstout) replacement strategy. Jouppi found that a 4-line victim cache removed 20% to 95% of misses in the direct-mapped cache. An improvement to the victim cache scheme known as selective victim cache. In this scheme, incoming blocks into the first-level cache are placed selectively in the main cache or the victim cache by the use of a prediction scheme based on their past history of use. In addition, interchanges of blocks between the main cache and the victim cache are also performed selectively [5].

This paper proposed that,Victim caching was proposed by Jouppias an approach to improve the miss rate of direct-mapped caches. This approach augments the direct-mappedmain cache with a small fully-associate cache, calledvictim cache that stores cache blocks evicted from themain cache as a result of replacements. Author proposeand evaluate an improvement of this scheme, calledselective victim caching. In this scheme, incomingblocks into the first-level cache are placed selectivelyin the main cache or the victim cache by the use of aprediction scheme based on their past history of use.In addition, interchanges of blocks between the maincache and the victim cache are also performed selectively. Author show that the scheme results in significantimprovements in miss rate as well as the number ofinterchanges between the two caches, for both smalland large caches (4 Kbytes ~ 128 Kbytes). [6].

# International Journal of Innovative Research in Computer and Communication Engineering

(An ISO 3297: 2007 Certified Organization)

Website: [www.ijircce.com](http://www.ijircce.com)

Vol. 5, Issue 6, June 2017

## III. CACHE MEMORY

Now a days computers are designed to operate with different types of memory organized in a memory hierarchy. In such memory hierarchies, as the distance of the memories increases from the processor, as the distance from the processor increases, so that the access time for each memory increases. Closest to the CPU is the Cache Memory. Cache memory is fast but quite small; it is used to store small amounts of data that have been accessed recently and are likely to be accessed again soon in the future. Data is stored here in blocks, each containing a number of words. To keep track of which blocks are currently stored in Cache, and how they relate to the rest of the memory, the Cache Controller stores identifiers for the blocks currently stored in Cache. These include the index, tag, valid and dirty bits, associated with a whole block of data. To access an individual word inside a block of data, a block offset is used as an address into the block itself. Using these identifiers, the Cache Controller can respond to read and write requests issued by the CPU, by reading and writing data to specific blocks, or by fetching or writing out whole blocks to the larger, slower Main Memory. Figure 1 shows a block diagram for a simple memory hierarchy consisting of CPU, Cache (including the Cache controller and the small, fast memory used for data storage), Main Memory Controller and Main Memory proper.

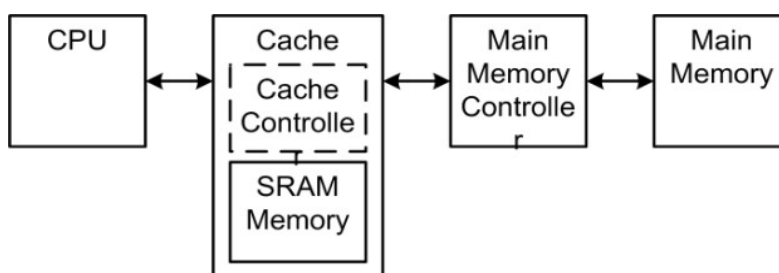

Fig. 1: Memory Hierarchy Block Diagram [8]

When the processor request data, the cache checks to see if that address is present in cache memory or not, if address present in cache then cache hit occurs else it will cache miss. If the cache contains the memory location, then the cache hit occurs. If the cache does not contain the memory location, then the cache miss occurs.

### 3.1 Cache Organization

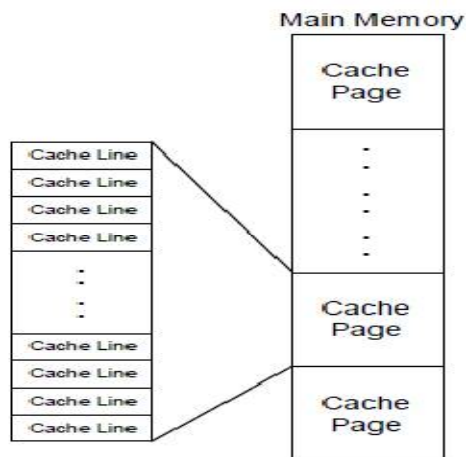

Fig. 2: Cache Page [8]

# International Journal of Innovative Research in Computer and Communication Engineering

(An ISO 3297: 2007 Certified Organization)

Website: [www.ijircce.com](http://www.ijircce.com)

Vol. 5, Issue 6, June 2017

In cache organization fig 2 the main memory is divided into pages which are known as cache pages, where the size of cache pages is equal to the size of cache memory. Further cache pages are divided into cache lines.

### 3.2 Fully-Associative

This scheme allows any line in main memory to be stored at any location in cache. Fully associative cache does not use cache pages it use only cache lines. Main memory and cache memory are both divided into lines of equal size. Any cache line may store any memory line, hence the name fully associative.

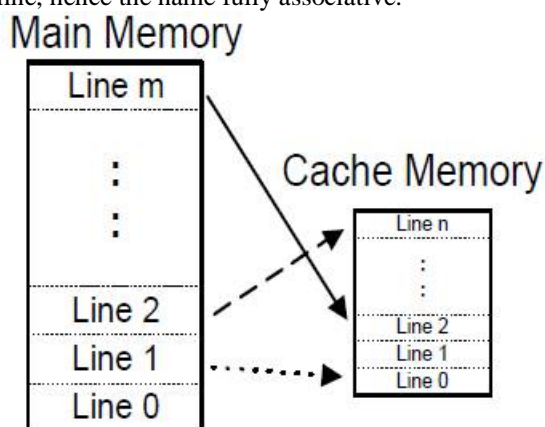

Fig. 3: Fully Associative cache [8]

### 3.2 Direct Map

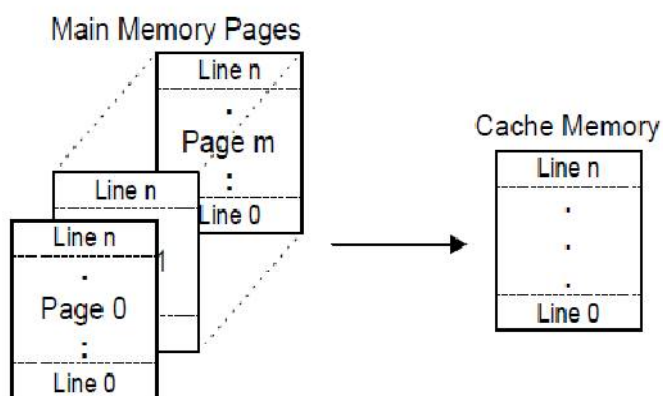

Fig. 4: Direct Mapped Cache [8]

In this scheme fig 4 main memory is divided into cache page. Direct map cache may only store a specific line of memory within the same line of cache. This scheme directly maps a memory line, hence the name direct mapped cache.

## IV. VICTIM CACHE

Cache memory is extremely fast memory that is built into a computer's central processing unit (CPU), or located next to it on a separate chip. The CPU uses cache memory to store instructions that are repeatedly required to run programs, improving overall system speed. The CPU can process data much faster by avoiding the bottleneck created by the system bus. Cache built into the CPU itself is referred to as cache. Cache that is built into the CPU is faster than separate cache, running at the speed of the microprocessor itself. However, separate cache is still roughly twice as fast

# International Journal of Innovative Research in Computer and Communication Engineering

(An ISO 3297: 2007 Certified Organization)

Website: [www.ijircce.com](http://www.ijircce.com)

Vol. 5, Issue 6, June 2017

as Random Access Memory (RAM). Cache is more expensive than RAM, but it is well worth getting a CPU and motherboard with built-in cache in order to maximize system performance. So, cache plays very important role in processing of CPU to be fast and for this the optimization of cache is also very necessary.

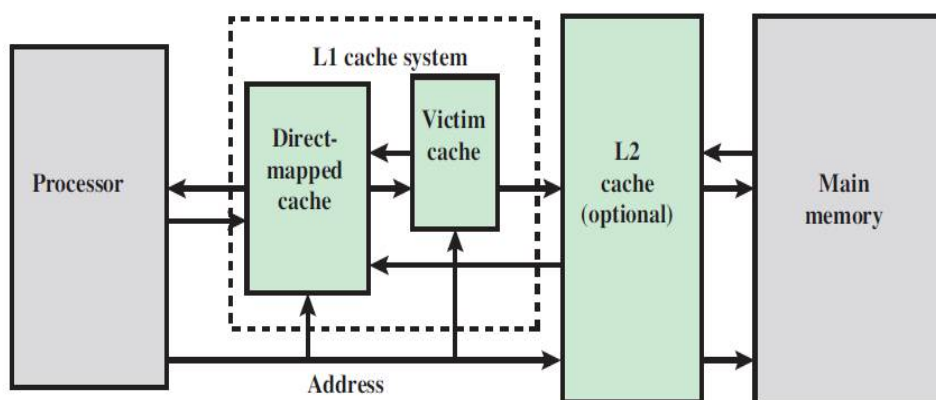

Fig 5: Memory hierarchy for the victim caching scheme.[5]

Figure 5 is a simple block diagram illustrating the location of the victim cache in the overall memory hierarchy. The victim cache can be considered to be part of the L1 cache system. The next lower level of the memory hierarchy can be an L2 cache or the main memory

The first-level (L1) cache consists of a direct-mapped main cache and a small fully-associative victim cache. A line buffer is included so that sequential accesses to words in the same cache block (line) do not result in more than one access to the cache, thus preventing repeated updates of state bits in cache. Upon the first access to a cache line, the entire line is brought into the line buffer in parallel with the execution in the CPU; subsequent accesses to words in the same line are satisfied from the line buffer and cause no update of state bits in cache. The next lower level of the memory hierarchy can be main memory. On every memory access, the line buffer, main cache, and the victim cache are searched in parallel. If the line is found in the line buffer, the instruction is fetched from there and no other action is necessary. Otherwise, three different cases must be considered:[5]

1. *Hit in main cache:* If the word is found in the direct-mapped cache, it is delivered to the CPU and the entire line containing the accessed word is brought into the line buffer.
2. *Miss in main cache, hit in victim cache:* In this case, the word is fetched from the victim cache into the line buffer and forwarded to the CPU.
3. *Miss in both main and victim caches:* If the word is not found both in the main cache and the victim cache, it must be fetched from the next level of the hierarchy.

Cache Hits: When the cache contains the information requested, the transaction is said to be a cache hit.

Cache Miss: When the cache does not contain the information requested, the transaction is said to be a cache miss.

# International Journal of Innovative Research in Computer and Communication Engineering

(An ISO 3297: 2007 Certified Organization)

Website: [www.ijircce.com](http://www.ijircce.com)

Vol. 5, Issue 6, June 2017

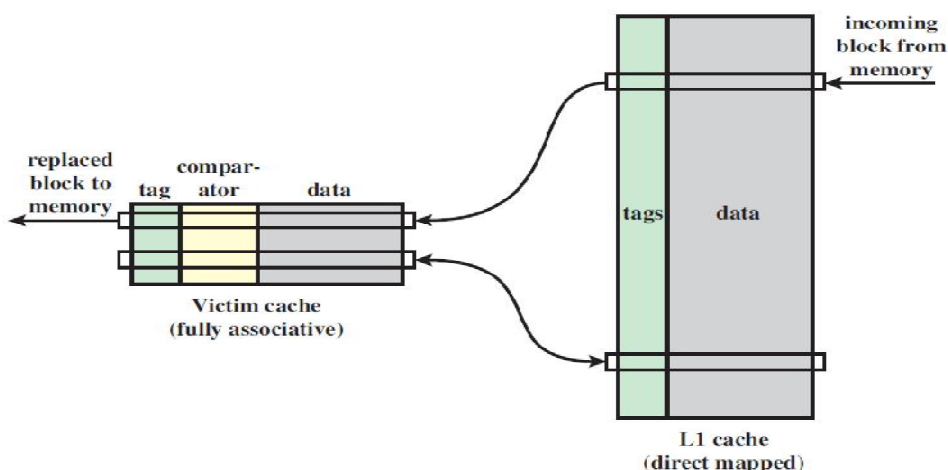

Fig. 6: Victim Cache Operation[5]

Figure 6 suggests the operation of the victim cache. The data is arranged in such a way that the same line is never present in both the L1 cache and the victim cache at the same time. There are two cases to consider for managing the movement of data between the two caches:

**Case 1:** Processor reference to memory misses in both the L1 cache and the victim cache.

- The required block is fetched from main memory (or the L2 cache if present) and placed into the L1 cache.
- The replaced block in the main cache is moved to the victim cache. There is no replacement algorithm. With a direct-mapped cache, the line to be replaced is uniquely determined.
- The victim cache can be viewed as a FIFO queue or, equivalently, a circular buffer. The item that has been in the victim cache the longest is removed to make room for the incoming line. The replaced line is written back the main memory if it is dirty (has been updated).

**Case 2:** Processor reference to memory misses the direct-mapped cache but hits the victim cache.

- The block in the victim cache is promoted to the direct-mapped cache.
- The replaced block in the main cache is swapped to the victim cache [5].

## V. STRUCTURE OF MEMORY

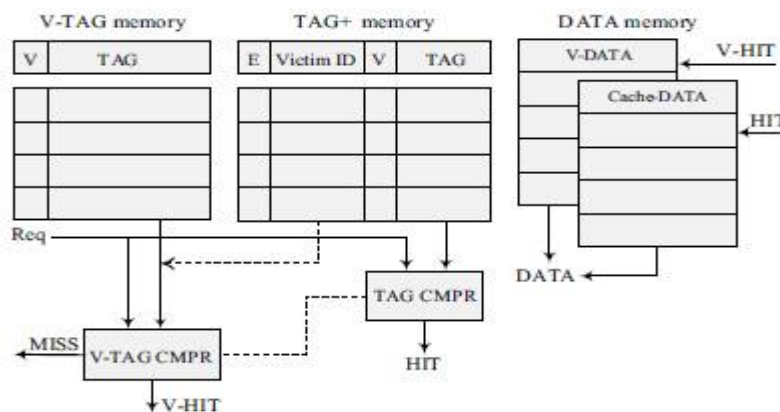

Fig 7: Cache Structure [1]



# International Journal of Innovative Research in Computer and Communication Engineering

(An ISO 3297: 2007 Certified Organization)

Website: [www.ijircce.com](http://www.ijircce.com)

Vol. 5, Issue 6, June 2017

The structure of the proposed cache architecture is shown in Fig 7. Which contains both the L1 cache and the victim cache associated with it. The data memory includes the data memory of the L1 cache (cache DATA) and that of the victim cache (V-DATA), accessed when the HIT or the VHIT (victim HIT) signals are asserted, respectively. The TAG storage in this architecture consist of two parts; the TAG+ memory and the V-TAG memory. Each word of the TAG+ memory is dedicated to one set in the L1 cache. This word stores the tag label of the currently available data in that set, the ID of the victim line assigned to the cache set, if any, and VALID and ENABLE bits to check the validity of the former parameters. The V-TAG (victim TAG) memory is the TAG storage part of the victim cache that stores the tag label of each victim data, and has a VALID bit to check the validity of the data currently stored in the corresponding data store line of the victim cache. [1]

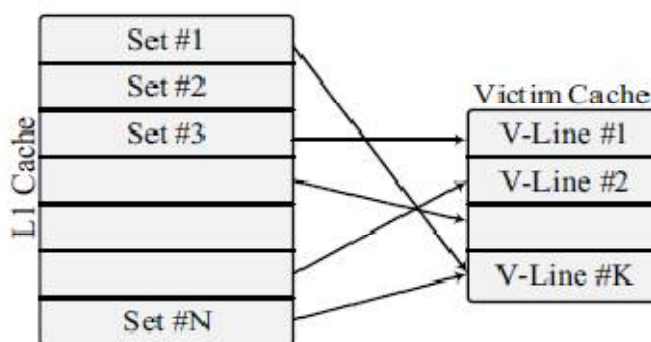

Fig 8: Cache mapping structure [1]

## VI. SYSTEM ARCHITECTURE

The victim cache contains fourteen cache lines worth of information, is fully-associative, and uses a FIFO (first in, first out) replacement policy. The reason for using FIFO instead of random as the first level cache is that random replacement is more effective for larger cache sizes. The small size of the victim cache makes it probable that certain cache blocks will be replaced more often. Because the victim cache outputs to the DRAM on a cache miss, replacing blocks on a more frequent basis will result in a higher Average memory access time. A FIFO replacement policy ensures each block has the same chance to be replaced.

For example let's consider cache system of two levels. Let level one cache be victim cache. Let the direct mapped cache module be sixteen sets. The fully associative cache module is four blocks. Let the line size be one byte. Let the address trace 4, 20, 4, 20, 36, 52. These addresses map to set four in the direct mapped cache of victim cache. The following happens in victim cache algorithm.

1. Address 4 is put in set 4 of direct mapped cache.
2. Address 20 is put in set 4 of direct mapped cache pushing address 4 to fully associative cache.
3. Address 4 is hit in fully associative cache swapped with address 20 of direct mapped cache.
4. Address 20 is hit in fully associative cache swapped with address 4 of direct mapped cache.
5. Address 36 replaces address 20 in direct mapped cache pushing address 20 to fully associative cache
6. Address 52 is replaces in direct mapped cache pushing address 36 to fully associative cache.

During above cache mapping, all four blocks of fully associative cache are searched for addresses 20, 4, 20, 36, 52 giving eighteen fully associative cache address match. There are two hits in the above trace.

# International Journal of Innovative Research in Computer and Communication Engineering

(An ISO 3297: 2007 Certified Organization)

Website: [www.ijircce.com](http://www.ijircce.com)

Vol. 5, Issue 6, June 2017

## VII. RTL VIEW OF VICTIM CACHE

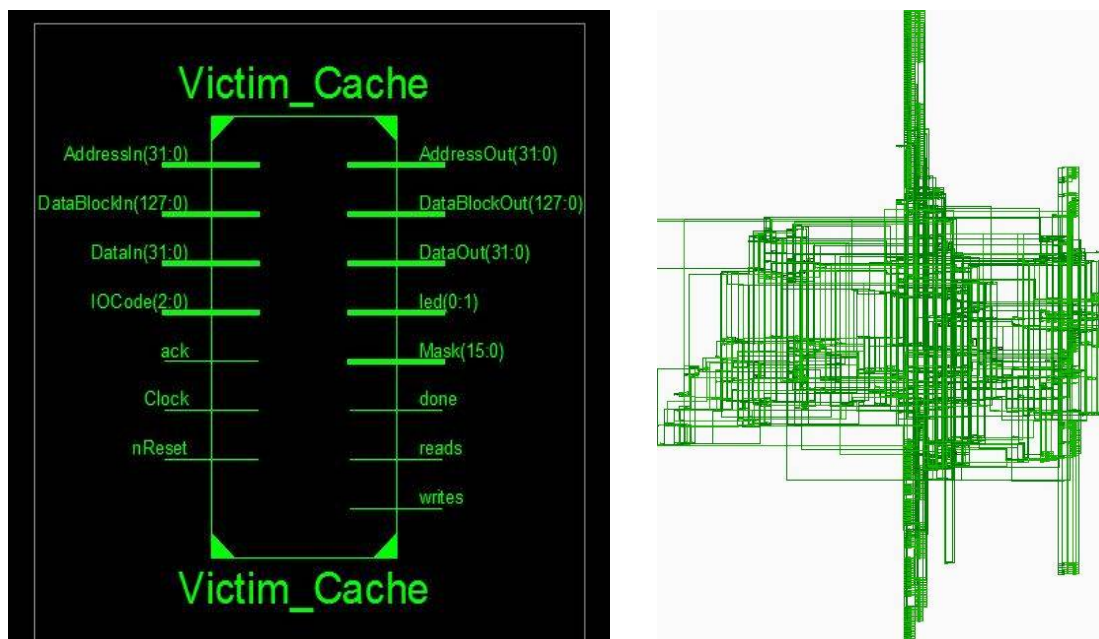

Fig 9: Victim Cache RTL view

The above fig 9 shows the implementation of victim cache. To achieve the synthesis of victim cache memory Xilinx ISE 14.2 platform is used. Initially addresses write into Cache tag memory through fill address when we=1 and data is write into cache data memory through 32-bit datain. When 32-bit address requested by microprocessor then address used first 14 bit out of 32-bit for addressing purpose and 18-bit address is used for comparison with 18-bit addresses store in cache Tag memory. 18-bit cache Tag comparator is used for Comparison. If Requested address found in cache memory then cache hit will occurs and corresponding data related to requested address given to microprocessor through 32-bit data out. The data memory is of 4KB. With 32bit for each cache line, the cache has 128 data lines. For each line, a tag label is stored in the TAGmemory, forming a TAG memory of 128 entries. As mentioned earlier, a total number of 14 victim lines are considered in this design. That is, 14 victim lines of 32bit and 14 victim tag entries. A physical memory of 1KB is used for storing TAG, Victim TAG, and victim lines

## VIII. SIMULATION RESULTS

Figure 10 shows the simulation results of victim cache memory. Code for victim cache is written in a VHDL. Xilinx platform is used for simulation. To achieve the synthesis of victim cache memory, Xilinx platform is used. as shown in simulation results it is found that if address requested by microprocessor is matched with the address stored in cache tag memory then the cache hit will occurs, if not then cache miss will occurs.



# International Journal of Innovative Research in Computer and Communication Engineering

(An ISO 3297: 2007 Certified Organization)

Website: [www.ijircce.com](http://www.ijircce.com)

Vol. 5, Issue 6, June 2017

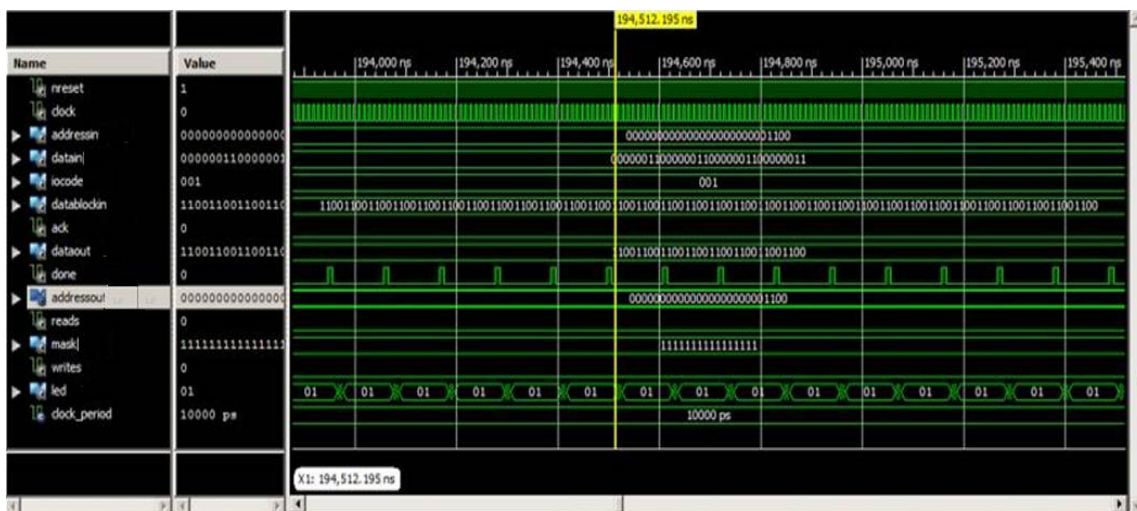

Fig 10: Victim Cache simulation

## IX. CONCLUSION

In this paper, we have presented design of victim cache memory for detecting cache. The use of victim cache increases the performance of cache memory by reducing miss's occurred during operation. Such an approach would be of great utility to many modern embedded applications, for which both high-performance and low-power are of great importance.

## REFERENCES

1. MehrdadBiglari, KamyarBarijough, MaziarGoudarzi, BehnazPourmohseni "A Fine-Grained Configurable Cache Architecture for Soft Processors", In 2015 18th CSI International Symposium on Computer Architecture and Digital Systems (CADS).
2. M. Z. Zhao, and J. S. Vetter, "FlexiWay: A Cache Energy Saving Technique using Fine-grained Cache Reconfiguration", In 31<sup>st</sup> IEEE International Conference on Computer Design, pp. 100-107, 2013.
3. C. Zhang, F. Vahid and R. Lysecky, "A Self-Tuning Cache Architecture for Embedded Systems", In Conference Proceedings of Design, Automation, and Test in Europe, pp. 142-147, 2004.
4. A. Agrawal, and S. D. Pudar, "Column-associative Caches: a Technique for Reducing the Miss Rate of Direct-mapped Caches", In 20th Annual International Symposium on Computer Architecture, pp. 179-190, 1993.
5. William Stallings: APPENDIX D VICTIM CACHE STRATEGIES, Computer Organization and Architecture, Ninth Edition Prentice Hall 2012 ISBN: 013293633X.
6. DimitriosStiliadis, AnujanVarma, "Selective Victim Caching: A Method to Improve the Performance of Direct-Mapped Caches" In Proceedings of the Twenty-Seventh Annual Hawaii International Conference on System Sciences, 1994.
7. Jouppi, N. "Improving Direct-Mapped Cache Performance by the Addition of a Small Fully-Associative Cache and PrefetchBuffers." *Proceedings, 17th Annual International Symposium on ComputerArchitecture*, May 1990.
8. COE758 – Digital Systems Engineering, Project #1 – Memory Hierarchy: Cache Controller.