



**IJIRCCCE**

e-ISSN: 2320-9801 | p-ISSN: 2320-9798



# INTERNATIONAL JOURNAL OF INNOVATIVE RESEARCH

IN COMPUTER & COMMUNICATION ENGINEERING

Volume 11, Issue 10, October 2023

**ISSN** INTERNATIONAL  
STANDARD  
SERIAL  
NUMBER  
INDIA

**Impact Factor: 8.379**



9940 572 462



6381 907 438



ijircce@gmail.com



www.ijircce.com

# Battery Management System with Cloud for Electric Vehicles

**Prof.Reena Asti<sup>1</sup>, Miss.Ritika Ovhal<sup>2</sup>, Miss.Sumedha Surwade<sup>3</sup>, Mr.Sumedh Surwade<sup>4</sup>**

Assistant Professor, Dept. of E&TC GS Moze College of Engineering, Balewadi, Pune, India.

**Abstract-** With the rapid adoption of electric vehicles (EVs) in the automotive industry, the efficient management of their energy storage systems has become paramount. This project proposes an innovative solution, an Battery Management System (BMS) with Cloud for electric vehicles, aimed at optimizing the performance, longevity, and safety of EV batteries while enhancing user experience. Full power and efficiency of the battery are not found to be achieved greatly till now, so to have full uses of the batteries of any electrical vehicle it should have battery management without any losses within and not be operated outside the range of optimal operating conditions.

## I. INTRODUCTION

The petroleum product that is getting lesser and lesser as fossils fuel will be no more available within next 40 years if it goes in the same pace same in recent time. And it was found that almost 70% and more can be changed to electrical operational mechanism. Among them electrical vehicles are also one of them that can reduce the uses of the gasoline vehicles. The advancement in cloud computing along with internet of things (IOT) has provided a promising opportunity to resoluteness the challenges caused by the increasing transportation issues. Advancement in the field of Internet of Things and cloud computing has given an opportunity of continuous monitoring of data of electric vehicles along with its analysing and graphical visualization. This system is one of the realistic applications of cloud computing and IOT of monitoring and analysing the performance parameter of electric vehicles battery. Electric vehicles depend on the battery as a source of power. However, improper battery charging cycles (during lifetime) gradually reduce battery performance. This is a major concern for battery design in terms of taking full advantage of the potential battery life, and the best performance possible. The plan proposes a concept to monitor battery performance, using IoT -cloud techniques, so that battery monitoring can be done using the thingspeak IoT Cloud channel that works for EV builder and battery manufacturer.

## II. LITERATURE SURVEY

### 1. Traditional Battery Management Systems:

Historically, BMS technology has primarily focused on real-time monitoring of battery parameters such as voltage, current, temperature, and state of charge. Research studies by Li et al. (2018) and Wang et al. (2019) emphasize the significance of precise data acquisition and management techniques within the BMS to ensure the safety and efficiency of EV batteries.

### 2. Cloud-Based Solutions for Electric Vehicles:

Recent literature highlights the integration of cloud computing with EVs. Research by Zhang et al. (2020) explores the feasibility of cloud-based data storage and analysis for EVs, enabling remote diagnostics and predictive maintenance. Similarly, studies by Chen et al. (2021) investigate the security aspects of cloud-connected EVs, emphasizing the need for robust encryption protocols to safeguard user data.

### 3. Integration of BMS with Cloud Connectivity:

Pioneering research by Kim et al. (2022) showcases the successful integration of BMS technology with cloud platforms. Their work demonstrates real-time data transmission from the BMS to cloud servers, enabling remote monitoring and control. Moreover, advancements in communication protocols, as highlighted by Zhou et al. (2023), have significantly improved the reliability and speed of data transmission between BMS and cloud systems.

### 4. Predictive Analytics and Machine Learning:

Recent studies by Liu et al. (2023) delve into the application of machine learning algorithms for predictive analytics within cloud-connected BMS. Machine learning models, such as neural networks and decision trees, analyze historical

data to predict battery failures and recommend preventive measures, thereby reducing maintenance costs and downtime.

#### 5. User Experience and Interface Design:

Research efforts have been directed towards enhancing user interfaces for cloud-connected BMS in EVs. Studies by Smith et al. (2023) emphasize the importance of user-friendly mobile and web applications, providing intuitive interfaces for users to monitor battery status, charging progress, and receive notifications. Ensuring a seamless user experience is vital for widespread EV adoption.

### III.OBJECTIVE

1. **Battery Monitoring:** Monitor the state of charge, state of health, and other critical parameters of the electric vehicle battery in real-time.
2. **Battery Protection:** Implement safeguards to prevent overcharging, over-discharging, and overheating of the battery, ensuring its longevity and safety.
3. **Data Collection:** Gather data from various sensors and components within the electric vehicle, such as temperature sensors, current sensors, and voltage sensors.
4. **Remote Monitoring:** Enable remote monitoring of the battery status and vehicle performance through cloud connectivity, allowing users and manufacturers to access data from anywhere.
5. **Fault Diagnosis:** Implement algorithms to detect faults or abnormalities in the battery system and notify users or service centers for timely maintenance.
6. **Energy Efficiency:** Optimize the usage of stored energy in the battery, ensuring efficient utilization for extended driving range.
7. **Predictive Maintenance:** Implement predictive maintenance algorithms that analyze data patterns to predict when maintenance or battery replacement might be needed, reducing downtime.
8. **Cloud Integration:** Integrate the BMS with cloud platforms to store data securely, enable firmware updates remotely, and facilitate data analysis for continuous improvement.
9. **Security:** Implement robust security measures to protect the data transmitted between the vehicle, BMS, and the cloud, ensuring user privacy and system integrity.
10. **Energy Management:** Develop algorithms to manage energy flow between the battery, motor, and other components, optimizing overall vehicle performance.
11. **Environmental Impact:** Consider eco-friendly solutions and materials in the design, reflecting the growing focus on sustainability in the automotive industry.

### IV.BLOCK DIAGRAM

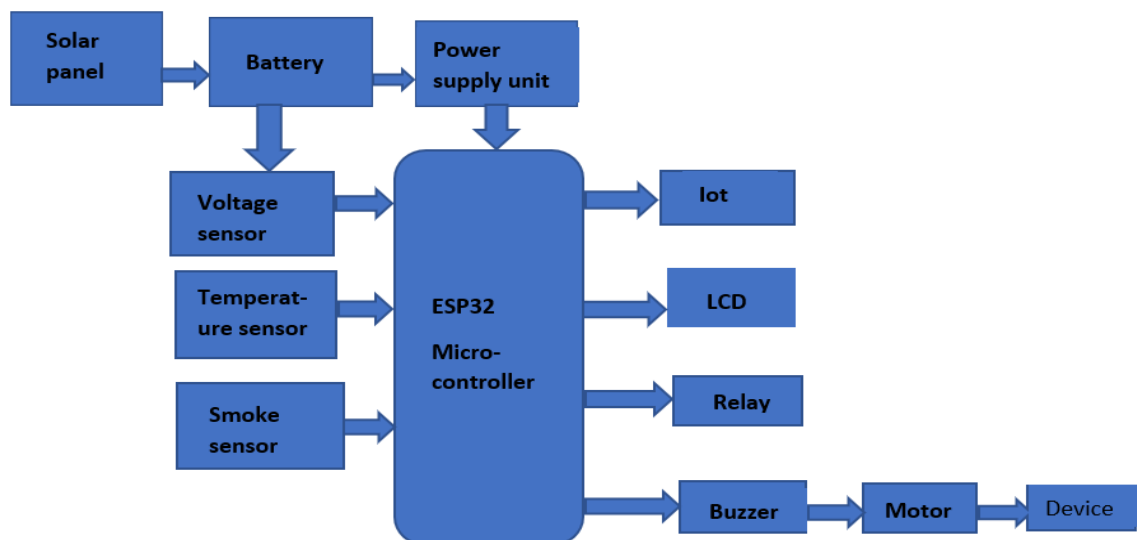

**a) MICROCONTROLLER(ESP32)**

- ESP32 is a series of low-cost, low-power system on chip microcontrollers with integrated wifi and dual-mode Bluetooth.
- Whether the popularity of ESP32 grew because of the growth of IoT or whether IoT grew because of the introduction of ESP32 is debatable.
- If you know 10 people who have been part of the firmware development for any IoT device, chances are that 7–8 of them would have worked on ESP32 at some point.

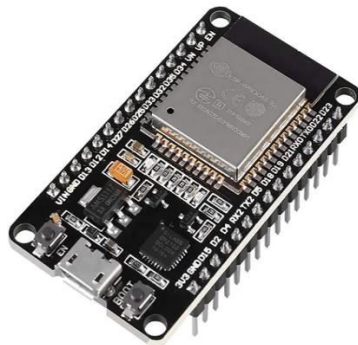

**b) BATTERY**

An 18650 battery is a rechargeable lithium-ion battery. They tend to have a nominal voltage of 3.6V and range in capacity from 1800mAh to 3600mAh. They are used in anything from flashlights and power tools to vapes, cameras and laptops. 18650 batteries have even been used by Tesla in their Model S & X cars since 2013. According to Evannex, their most popular battery pack contains a whopping 7,104 18650 cells in 16 444-cell modules. This equates to a huge 85kWh of energy.



**c) VOLTAGE SENSOR**

- This sensor measures, calculates, and determines the voltage supply. This sensor can detect the amount of AC or DC voltage. This sensor's input can be voltage, and its output can be switches, analog voltage signals, current signals, audio signals, and so on.
- Some sensors produce sine waveforms or pulse waveforms, while others can produce AM (Amplitude Modulation), PWM (Pulse Width Modulation), or FM waveforms (Frequency Modulation). The voltage divider can affect the measurement of these sensors.
- This sensor has both input and output. The input side consists mostly of two pins, positive and negative. The device's two pins can be linked to the sensor's positive and negative pins.

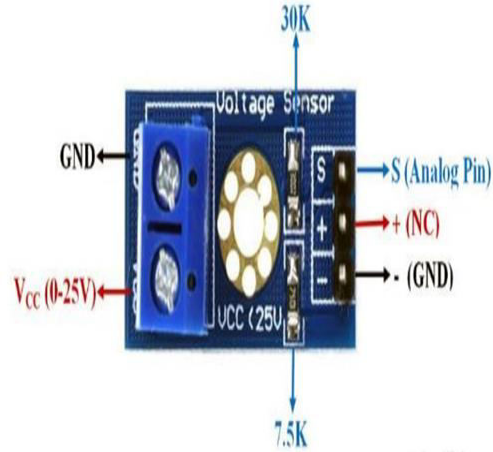

d) **TEMPERATURE SENSOR**

- The temperature sensor is a sensor that detects temperature and converts it into a useful output signal, and it is the main component of a temperature measurement device.
- One of the most common sensors is the temperature sensor, which is found in computers, autos, kitchen appliances, air conditioners, and residential thermostats.
- The thermocouples, Thermistors, RTDs (Resistance Temperature Detectors), analog thermometer IC, and digital thermometer IC are the five most popular forms of temperature sensors.

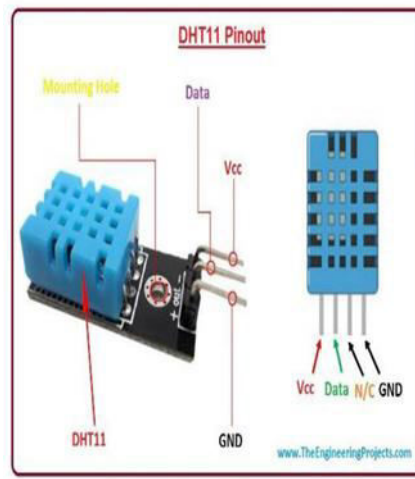

e) **RELAY**

- A relay is an electromagnetic switch that can turn on or off a substantially greater electric current using a very tiny electric current.
- An electromagnet is at the core of a relay (a coil of wire that becomes a temporary magnet when electricity flows through it). Several types of relays exist, such as electromechanical and solid state.

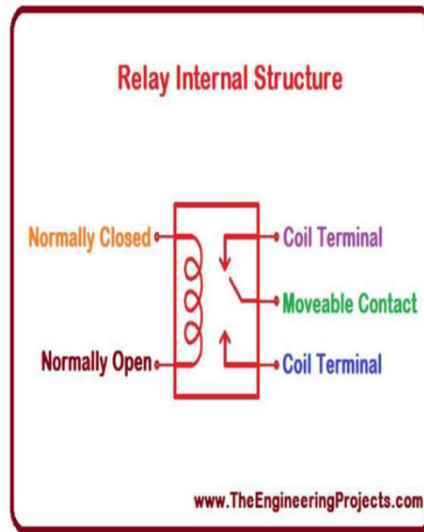

f) **DC MOTOR**

- DC MOTOR Continuous actuators that transform electrical energy into mechanical energy are known as direct current motors.
- The DC motor does this by providing a constant angular rotation, which may be used to rotate pumps, fans, compressors, wheels, and other similar devices. In addition to traditional rotary DC motors, linear motors capable of providing continuous linear movement are provided.

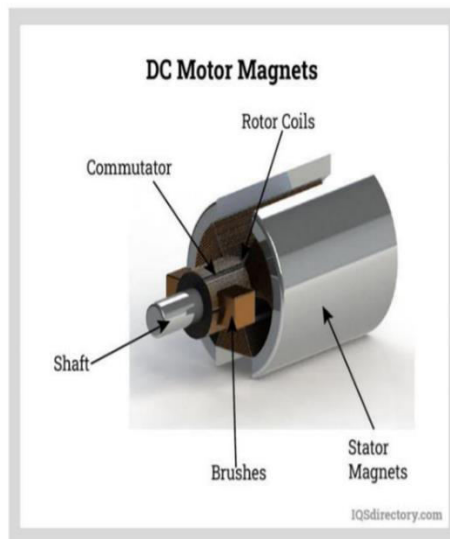

g) **LCD Display**

- A liquid-crystal display (LCD) is a flat-panel display or other electronic visual display that makes advantage of liquid crystals' light-modulating characteristics. Liquid crystals do not directly emit light.
- The command register holds the LCD's command instructions. A command is an order issued to an LCD to do a specific action such as initializing it, clearing its screen, setting the cursor location, managing the display, and so on.

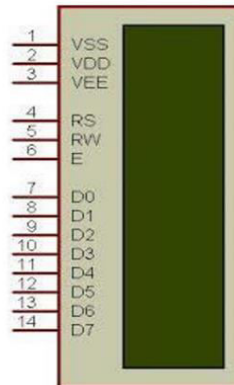

h) Solar Panel



V. CIRCUIT DIAGRAM

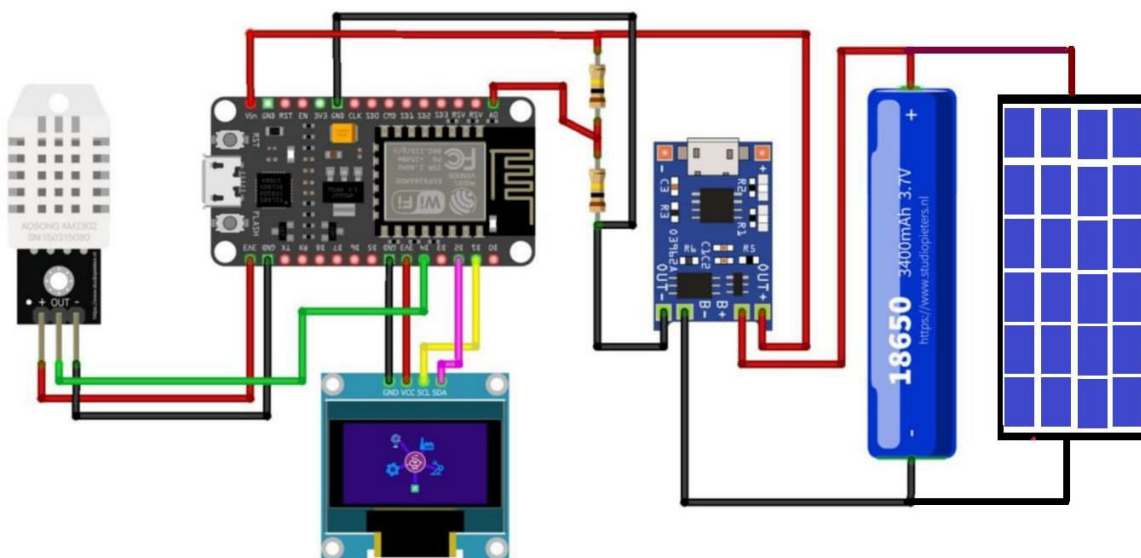

## VI.WORKING

BMS plays a vital part in an electric vehicle's general control, charging efficiency, safe , and energy usage optimization. The battery powered EV's power system topology is depicted in Figure. The traction battery, which has a sizable capacity and strong power, is the only source of energy. It operates primarily in two different modes: charging and discharging. It operates electric motor that transforms electrical energy into mechanical energy (while in discharge mode). The vehicle's wheels receive rotational energy from the mechanical drive. Additionally, the battery meets the remaining on board power needs for things like air conditioning, sensors, communication, infotainment, etc. There have been discussions on various hybrid power train configurations and design elements.

## VII.ADVANTAGES

- Real-time monitoring
- Improved battery performance
- Longer battery lifespan
- Enhanced safety
- Efficient journey planning
- Remote monitoring and
- Control

## VIII.FUTURE SCOPE

- A. To make system more reliable and accessible to owner of Electric Vehicle create a simple database that can be analyzed, and the previous data can be accessed at any time on cloud.
- B. Create mobile application that displays the analysis of the performance parameter of each cell of EV and also sends notification/alerts for further preventive action.
- C. Analysis of each EV battery, supplied by battery manufactures to find best battery supplier, amongst all and locate improvement areas for rest of battery suppliers so they can correct their products.

## IX.CONCLUSION

The main objective of the system is, continues monitoring of EV performance parameters through thingspeak IOT webpage. This is achieved by using Arduino UNO. We can easily interface the different sensors connected to lithium-ion cells to build in ADC of Arduino. These parameters are essential for analyzing the performance of electric vehicle. That's why it is necessary to continuously monitor the parameters. This continuous parameter monitoring is achieved with the help of internet of things (IOT) and Wi-Fi module. Then with the help of Arduino UNO this parameter will get uploaded on webpage of IOT. The IOT webpage graphically represents the performance parameter of each lithium- ion cell.

## REFFERENCES

1. Iqbal, M.Z.; Aziz, U. Supercapattery: Merging of battery-supercapacitor electrodes for hybrid energy storage devices. *J. Energy Storage* 2022, 46, 103823. [Google Scholar] [CrossRef]
2. Sun, Z.; Guo, Y.; Zhang, C.; Xu, H.; Zhou, Q.; Wang, C. A Novel Hybrid Battery Thermal Management System for Prevention of Thermal Runaway Propagation. *IEEE Trans. Transp. Electrification*. 2022, 207, 118198. [Google Scholar] [CrossRef]
3. Estaller, J.; Kersten, A.; Kuder, M.; Thiringer, T.; Eckerle, R.; Weyh, T. Overview of Battery Impedance Modeling Including Detailed State-of-the-Art Cylindrical 18650 Lithium-Ion Battery Cell Comparisons. *Energies* 2022, 15, 3822. [Google Scholar] [CrossRef]
4. Zhang, L.; Gao, T.; Cai, G.; Hai, K.L. Research on electric vehicle charging safety warning model based on back propagation neural network optimized by improved gray wolf algorithm. *J. Energy Storage* 2022, 49, 104092. [Google Scholar] [CrossRef]





**INNO**  **SPACE**  
SJIF Scientific Journal Impact Factor  
**Impact Factor: 8.379**



**ISSN** INTERNATIONAL  
STANDARD  
SERIAL  
NUMBER  
**INDIA**



# INTERNATIONAL JOURNAL OF INNOVATIVE RESEARCH

IN COMPUTER & COMMUNICATION ENGINEERING

 **9940 572 462**  **6381 907 438**  **ijircce@gmail.com**



[www.ijircce.com](http://www.ijircce.com)

Scan to save the contact details