



International Journal of Innovative Research in Computer and Communication Engineering

(A Monthly, Peer Reviewed, Refereed, Scholarly Indexed, Open Access Journal)





International Journal of Innovative Research in Computer and Communication Engineering (IJIRCCCE)

(A Monthly, Peer Reviewed, Refereed, Scholarly Indexed, Open Access Journal)

Smart Fire Detection System Using Raspberry Pi

G.Srihas¹, V.Krishna Teja², G.Sharmili Krishna³, B.Sudhakar Rao⁴

U.G. Student, Department of ECE, SVIET Engineering College, Nandamuru, Pedana, Andhra Pradesh, India^{1,2,3}

Assistant Professor, Department of ECE, SVIET Engineering College, Nandamuru, Pedana, Andhra Pradesh, India⁴

ABSTRACT: Fire accidents pose a serious threat to human life, industrial assets, and public infrastructure. Early detection and quick response are essential to minimize damage caused by fire incidents. Conventional fire detection systems rely mainly on smoke detectors and heat sensors that trigger alarms locally. These systems often lack intelligent monitoring, visual confirmation, and automated suppression mechanisms, which may lead to delayed response and increased damage. This project presents a Smart Fire Detection and Suppression System using Raspberry Pi 3. The Raspberry Pi acts as the central controller and continuously monitors environmental conditions using fire-related sensors. When abnormal conditions indicating potential fire are detected, a USB camera connected to the Raspberry Pi captures images of the monitored area. To provide wider monitoring coverage, the camera is mounted on a stepper motor-based rotating mechanism that allows the system to scan different directions. Once fire is detected and confirmed, the Raspberry Pi activates a relay module connected to a DC water pump. The pump automatically sprays water to suppress the fire and prevent it from spreading. The system can also display captured images and system status through a monitoring interface. The proposed solution improves fire detection reliability and response time by integrating sensor monitoring, camera surveillance, and automated fire suppression. This system can be effectively deployed in residential buildings, industries, warehouses, and other fire-prone environments.

KEYWORDS: Raspberry Pi, Fire Detection, Embedded Systems, Smart Monitoring, Fire Suppression, IoT.

I. INTRODUCTION

Fire accidents are one of the most dangerous hazards affecting human life and property. Fires can occur in various environments such as residential buildings, industries, warehouses, laboratories, and commercial infrastructures. These incidents may result from electrical faults, overheating equipment, gas leaks, or accidental ignition sources. Early fire detection is crucial to prevent the rapid spread of flames and minimize potential damage. Traditional fire detection systems usually consist of smoke detectors and heat sensors connected to alarm units. When abnormal environmental conditions are detected, these systems activate alarms to alert occupants.

Although traditional systems provide basic fire protection, they have several limitations. Most conventional systems only generate local alarm signals and do not provide remote monitoring or detailed information about the fire incident. In many cases, authorities or building managers cannot determine the exact location or severity of the fire until they physically inspect the area. Another limitation of traditional systems is the lack of visual monitoring. When an alarm is triggered, there is no camera system to verify whether the fire is real or caused by environmental disturbances such as dust or steam. This may lead to false alarms and delayed response during actual emergencies. With advancements in embedded systems and smart computing technologies, it has become possible to develop intelligent monitoring solutions that combine sensors, cameras, and automated control mechanisms.

The Raspberry Pi is a powerful single-board computer capable of processing camera data, capturing images, controlling external devices, and running monitoring software simultaneously. Due to its flexibility and low cost, it is widely used in IoT and automation projects. The proposed system utilizes Raspberry Pi 3 to monitor environmental conditions, capture images of suspected fire areas, and activate a water pump through a relay module to suppress fire automatically. This integrated approach enhances fire safety and improves response time.

II. RELATED WORK

Many researchers have developed fire detection systems using sensors and microcontrollers. Earlier systems mainly used smoke sensors and temperature sensors to detect fire conditions. These systems were simple but sometimes



International Journal of Innovative Research in Computer and Communication Engineering (IJIRCCCE)

(A Monthly, Peer Reviewed, Refereed, Scholarly Indexed, Open Access Journal)

produced false alarms or delayed responses. With the advancement of IoT, modern systems use Raspberry Pi and wireless communication to send real-time alerts to users.

Some systems also include cameras and image processing techniques to visually detect fire. Vision-based systems use color detection methods such as RGB and HSV to identify fire in images. However, these systems may be affected by lighting conditions and similar colors. To improve accuracy, recent research combines both sensor-based and vision-based detection methods. This hybrid approach reduces false alarms and increases reliability. However, there is still scope for improvement in accuracy and response time.

III. METHODOLOGY

The proposed smart fire detection system using Raspberry Pi is designed to continuously monitor environmental conditions and detect fire in real time. In this system, camera is used to detect fire-related parameters. These camera send data to the Raspberry Pi, which acts as the main processing unit. A Pi Camera is used to capture real-time images. The Raspberry Pi processes these images using image processing techniques to detect fire based on color patterns

Using IoT technology, the processed data is transmitted to an online platform through Wi-Fi, allowing users to monitor the system remotely. The system also displays information on an LCD screen for local monitoring. When fire is detected, the system sends alert messages nearby people and sends notifications to users. Additionally, a water pump can be activated automatically to control the fire.

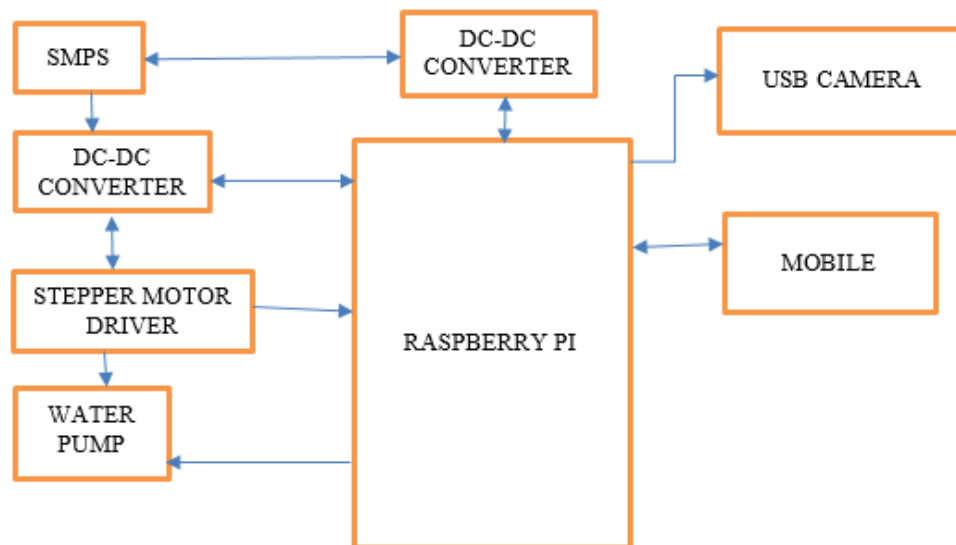

FIG 1: BLOCK DIAGRAM OF SMART FIRE DETECTION SYSTEM USING RASPBERRY PI

Fig 1 shows the block diagram of the smart fire detection system using Raspberry Pi. The system is designed to detect fire at an early stage and take necessary actions automatically to reduce damage. The SMPS (Switched Mode Power Supply) provides the required power to the entire system by converting AC supply into regulated DC voltage. The output is further maintained using DC-DC converters, which ensure that each component receives the appropriate and stable voltage for proper operation. The Raspberry Pi acts as the main controller of the system. It processes data from all connected components and controls the overall functioning. A USB camera is connected to the Raspberry Pi to capture real-time images of the surrounding area for fire detection. To increase the coverage area, a stepper motor is used, which rotates the camera in different directions. This helps the system to monitor a wider area and detect fire from multiple angles. When fire is detected through sensors or image processing, the Raspberry Pi activates a water pump to suppress the fire automatically. This reduces the spread of fire and improves safety. Additionally, the system sends alert notifications to a mobile device through Wi-Fi, enabling remote monitoring and quick response from the user.



International Journal of Innovative Research in Computer and Communication Engineering (IJIRCCE)

(A Monthly, Peer Reviewed, Refereed, Scholarly Indexed, Open Access Journal)

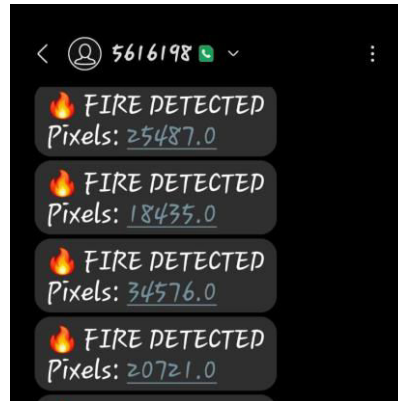

(e) alert notifications to users

Fig 2 shows the results smart fire detection system using raspberry pi (a) camera module detecting for fire,(b) fire pixels values with no fire detection,(c) camera module detected the fire,(d) fire pixels values with fire detected ,(e) alert notifications to users.

V. CONCLUSION

The Smart Fire Detection and Suppression System using Raspberry Pi represents a significant step forward in accessible, automated fire safety technology. By unifying sensor- based environmental monitoring, camera-based visual fire detection, and automated water pump suppression within a single low-cost embedded platform, the project demonstrates that effective automated fire response is achievable without the high costs traditionally associated with such systems. The system successfully achieves all objectives defined at the outset of the project.

The stepper motor-based camera scanning extends coverage beyond what a fixed camera could achieve. The relay-controlled water pump provides automatic suppression with an average response time of 2 seconds from fire establishment to pump activation. In conclusion, this project demonstrates the power of combining modern embedded computing platforms, affordable sensors, computer vision techniques, and thoughtful system design to create an intelligent safety solution that genuinely contributes to fire protection.

REFERENCES

1. Yamagishi, H. and Yamaguchi, J.(n.d.). A contour fluctuation data processing method for fire flame detection using a color camera. 26th Annual Conference of the IEEE Industrial Electronics Society. IECON.IEEE International Conference on Industrial Electronics, Control and Instrumentation. 21st Century Technologies and Industrial, pp.824-829, 2000.
2. Pritam, D., and Dewan, J. H. (2017). Detection of fire using image processing techniques with LUV color space. 2nd International Conference for Convergence in Technology (I2CT), pp.1158-1162, 2017.
3. Seebamrungsat, J., Praising, S., and Riyamongkol, P. (2014). Fire detection in the buildings using image processing. 2014 Third ICT International Student Project Conference (ICT-ISPC), pp.95-98, 2014.
4. Azmil, M. S. A., Ya'acob, N., Tahar, K. N., and Sarnin, S. S. (2015). Wireless fire detection monitoring system for fire and rescue application. 2015 IEEE 11th International Colloquium on Signal Processing and Its Applications (CSPA), pp.84-89, 2015.
5. Noorinder, Student Member IEEE, Jaspreet Singh, Member IEEE and Ekambir Sidhu, Member IEEE/IETE Raspberry Pi based Smart Fire Management System employing Sensor based Automatic Water Sprinkler in International Conference on Power and Embedded Drive Control (ICPEDC), 2017, pp.102-107.
6. Turgay Celik Fast and Efficient Method for Fire Detection Using Image Processing in ETRI Journal, Volume 32, Number 6, December 2010, pp. 881-890
7. Priyadarshini M Hanamaraddi* et al, "A Literature Study on Image Processing for Forest Fire Detection", in (IJITR) INTERNATIONAL JOURNAL OF INNOVATIVE TECHNOLOGY AND RESEARCH Volume No.4, Issue No.1,



International Journal of Innovative Research in Computer and Communication Engineering (IJIRCCE)

(A Monthly, Peer Reviewed, Refereed, Scholarly Indexed, Open Access Journal)

December - January 2016, 2695 - 2700.

8. K. Ramya''Survey on an Intelligent AAA Device for Fire Detection'' in International Journal of Advance Research, Ideas and Innovations in Technology (Volume 4, Issue 1),pp. 669-673,2018.

9. Ahmed Imteaj, Tanveer Rahman, Muhammad Kamrul Hossain, Mo hammed Shamsul Alam and Saad Ahmad Rahat An IoT based Fire Alarming and Authentication System for Workhouse using Raspberry Pi 3 in International Conference on Electrical, Computer and Communication Engineering (ECCE), February 16-18, 2017, Coks Bazar, Bangladesh,pp. 899-904.

10. Nurul Shakira Bakri, Ramli Adnan, Abd Manan Samad and Fazlina Ahmat Ruslan ''A Methodology for Fire Detection Using Color Pixel Classification'' in IEEE 14th International Colloquium on Signal Processing and its Applications (CSPA 2018), Penang, Malaysia, pp. 94-98, 20



INTERNATIONAL
STANDARD
SERIAL
NUMBER
INDIA



INTERNATIONAL JOURNAL OF INNOVATIVE RESEARCH

IN COMPUTER & COMMUNICATION ENGINEERING

 9940 572 462  6381 907 438  ijircce@gmail.com



www.ijircce.com

Scan to save the contact details