



**IJIRCCCE**

e-ISSN: 2320-9801 | p-ISSN: 2320-9798



# INTERNATIONAL JOURNAL OF INNOVATIVE RESEARCH

IN COMPUTER & COMMUNICATION ENGINEERING

Volume 12, Issue 5, May 2024

**ISSN** INTERNATIONAL  
STANDARD  
SERIAL  
NUMBER  
INDIA

**Impact Factor: 8.379**



9940 572 462



6381 907 438



ijircce@gmail.com



www.ijircce.com

# Design and Implementation of Convenient and Secure Voting System Using GSM and AI Tools

T.Jansi Rani, R.Jeeva, N.Karthick, Sabareeswaran.C

Assistant Professor, Department of Information Technology, P.S.V College of Engineering & Technology, Krishnagiri,  
Tamilnadu, India

UG Student, Department of Information Technology, P.S.V College of Engineering & Technology, Krishnagiri,  
Tamilnadu, India

UG Student, Department of Information Technology, P.S.V College of Engineering & Technology, Krishnagiri,  
Tamilnadu, India

UG Student, Department of Information Technology, P.S.V College of Engineering & Technology, Krishnagiri,  
Tamilnadu, India

**ABSTRACT:** Biometric Finger print devices are used in the Electronic Voting machine for voter verification. We have designed a finger print based voting machine where there is no need for the user to carry his ID which contains his required details. The person at the polling booth needs only to place his Finger on the device, thus allowing the acquisition of an on-spot fingerprint from the voter which serves as an identification. This Finger print reader reads the details from the tag. This data is passed onto the controlling unit for the verification. The controller fetches the data from the reader and compares this data with the already existing data stored during the registration of the voters. If the data matches with the pre-stored information of the registered fingerprint, the person is allowed to cast his vote. If not, a warning message is displayed on LCD and the person is barred from polling his vote. The vote casting mechanism is carried out manually using the push buttons. LCD is used to display the related messages, warnings and ensuing results.

**KEYWORDS:** Voter ID; Finger Print Module ; LCD ;

## I. INTRODUCTION

Biometrics is the science and technology of measuring and analyzing biological data. Biometrics refers to technologies that measure and analyze human body characteristics, such as DNA, fingerprints, eye retinas and irises, voice patterns, facial patterns and hand measurements, for authentication purposes. The field of biometrics was formed and has since expanded onto many types of physical identification. Among the several human fingerprints remain a very common identifier and the biometric method of choice among law enforcement. These concepts of human identification have led to the development of fingerprint scanners that serve to quickly identify individuals and assign access privileges. The basic point of these devices is also to examine the fingerprint data of an individual and compare it to a database of other fingerprints [1]. In our project we have used fingerprint for the purpose of voter identification or authentication. As the thumb impression of every individual is unique, it helps in minimizing the error. A database is created containing the fingerprint images of all the voters as required. Illegal votes and repetition of votes is checked for in this system with accurate coding. Hence with the application of this fingerprint based EVM system elections could be made fair and free from rigging. Further that the elections would be no longer a tedious and expensive job.

## II. LITERATURE SURVEY

### A. *Electronic Voting in India*

The Election Commission of India developed the country's EVMs in partnership with two government-owned companies, the Electronics Corporation of India (ECIL) and Bharat Electronics Limited (BEL). Though these companies are owned by the Indian government, they are not under the administrative control of the Election Commission. They are profit-seeking vendors that are attempting to market EVMs globally [7]. The first Indian EVMs were developed in the early 1980s by ECIL. They were used in certain parts of the country, but were never adopted nationwide. They introduced the style of system used to this day, including the separate control and ballot

units and the layout of both components. These first-generation EVMs were based on Hitachi 6305 microcontrollers and used firmware stored in external UV-erasable PROMs along with 64kb EEPROMs for storing votes. Second-generation models were introduced in 2000 by both ECIL and BEL. These machines moved the firmware into the CPU and upgraded other components. They were gradually deployed in greater numbers and used nationwide beginning in 2004 [3]. In 2006, the manufacturers adopted a third-generation design incorporating additional changes suggested by the Election Commission. According to Election Commission statistics, there were 1,378,352 EVMs in use in July 2009. Of these, 448,000 were third-generation machines manufactured from 2006 to 2009, with 253,400 from BEL and 194,600 from ECIL. The remaining 930,352 were the second-generation models manufactured from 2000 to 2005, with 440,146 from BEL and 490,206 from ECIL [4]. (The first generation machines are deemed too risky to use in national elections because their 15-year service life has expired [5], though they are apparently still used in certain state and local contests.) In the 2009 parliamentary election, there were 417,156,494 votes cast, for an average of 302 votes per machine [6].

**B. Evaluation of Voting Equipment**

In the recent years, voting equipment which were widely adopted may be divided into five types [7].

1) *Paper-based voting*: The voter gets a blank ballot and use a pen or a marker to indicate he want to vote for which candidate. Hand counted ballots is a time and labor consuming process, but it is easy to manufacture paper ballots and the ballots can be retained for verifying, this type is still the most common way to vote.

2) *Lever voting machine*: Lever machine is peculiar equipment, and each lever is assigned for a corresponding candidate. The voter pulls the lever to poll for his favorite candidate. This kind of voting machine can count up the ballots automatically. Because its interface is not user-friendly enough, giving some training to voters is necessary.

3) *Direct recording electronic voting machine*: This type, which is abbreviated to DRE, integrates with keyboard, touchscreen, or buttons for the voter press to poll. Some of them lay in voting records and counting the votes is very quickly. But the other DRE without keep voting records are doubted about its accuracy.

4) *Punch card*: The voter uses metallic hole-punch to punch a hole on the blank ballot. It can count votes automatically, but if the voter's perforation is incomplete, the result is probably determined wrongfully.

5) *Optical voting machine*: After each voter fills a circle correspond to their favorite candidate on the blank ballot, this machine selects the darkest mark on each ballot for the vote then computes the total result. This kind of machine counts up ballots rapidly. However, if the voter fills over the circle, it will lead to the error result of optical scan.

**III. BLOCK DIAGRAM**

The system aims at developing a fingerprint based advanced Electronic Voting Machine (EVM) which helps in free and fair way of conducting elections which are basis for democratic country like India .This project consists of following units a Voting system, fingerprint module and ARM controller Unit. The voter first puts his finger on the fingerprint module which checks for the authentication of the user. If the voter is the authenticated one, he will now poll his vote in the voting system by simply pressing button against his favorite leader through a button. The control unit consists of a ARM controller, push button for different operations of EVM. The votes casted for particular candidate in that particular section of constituency is shown through an LCD display. To perform this intelligent task, ARM controller is loaded with an intelligent program written in embedded „C“ language.

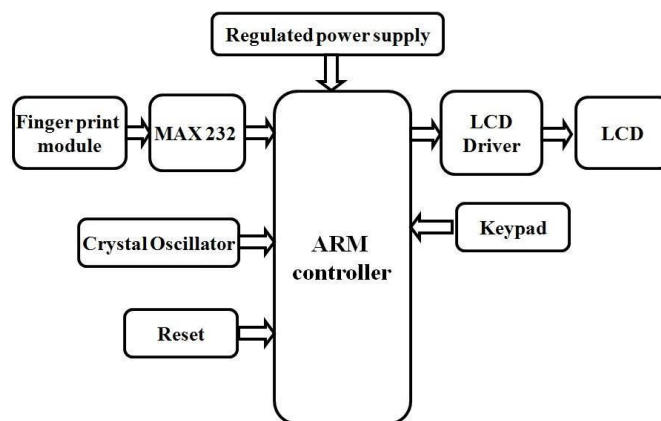

Fig. 1. Block diagram of biometric voting system

*A. ARM Controller*

ARM controller is Brain of this project, it has the features like 32-bit ARM7TDMI-S microcontroller in a tiny LQFP64 package. 8 kB to 40 kB of on-chip static RAM and 32 kB to 512kB of on-chip flash memory. 128-bit wide interface/accelerator enables high-speed 60 MHz operation. Various 32-bit timers, single or dual 10-bit ADC(s), 10-bit DAC, PWM channels and 45 fast GPIO lines with up to nine edge or level sensitive external interrupt pins make these microcontrollers suitable for industrial control and medical systems.

*B. Fingerprint module*

The device is the most popular among all the identification devices because of its ease in acquisition, and also the number of sources that are available for its data collection. It has found its vast use in law enforcement and immigration purposes. The module used here is R305. The basics of this identification process comes from “Galton points” – a certain characteristics defined by Sir Francis Galton, through which the fingerprints can be identified. In this module the scanned image are compared with an earlier existing finger print of yours to get the correct identity. The comparison is carried out by the processor and the comparison is made between the valleys and ridges though your whole fingerprint is recorded, the computer takes only parts of the print to compare with other records

*C. MAX-232*

The MAX-232 is an integrated circuit that converts signals from an RS-232 serial port to signals suitable for use in TTL compatible digital logic circuits. The MAX-232 is a dual driver/receiver and typically converts the RX, TX, CTS and RTS signals. The drivers provide RS-232 voltage level outputs (approx.  $\pm 7.5$  V) from a single + 5 V supply via on-chip charge pumps and external capacitors.

*D. Crystal oscillator*

An electronic oscillator is an electronic circuit that produces a repetitive Electronic signal, often a sine wave or a square wave. ARM controller internally having 4 Mhz clock frequency. We are giving the 60 Mhz clock frequency as an external source for increasing the system performance.

*E. Power source module*

The major blocks of power supply are given below Transformer, Rectifier, Filter, 7805 voltage regulator

#### IV. WORKING

will provide the regulated power supply to the unit which is first converted into 12V AC. 12V AC is converted into DC using rectifier circuit. Finally the 7805 voltage regulator provides constant 5V DC supply which will be given to circuit.

*F. Keypad*

Push buttons are used in keypad. A push-button or simply button is a simple switch mechanism for controlling some aspect of a machine or a process. Buttons are typically made out of hard material, usually plastic or metal.

*G. Reset*

This button is used to reset the whole system so that it can be configured for next election.

This process basically consist of two stages

A. Enrollment

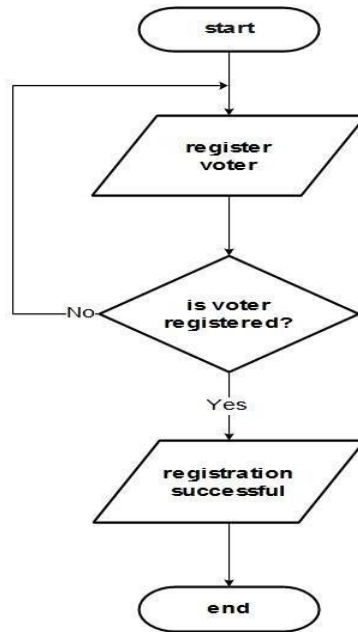
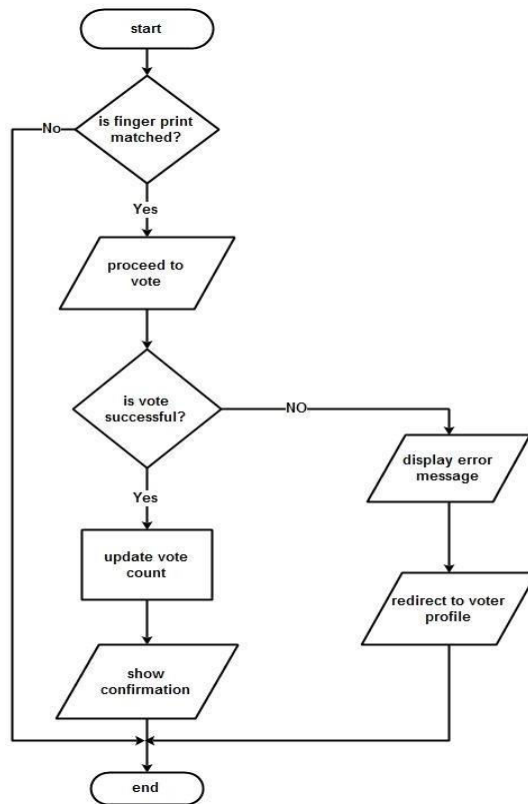

Fig. 2. Voter enrollment

1) Voter enrollment



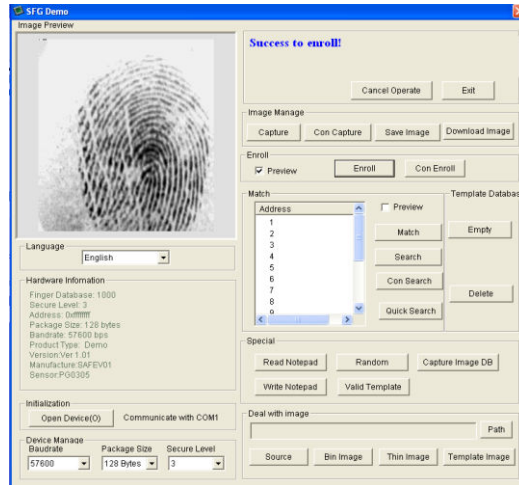

Fig. 3. Vote casting

**B. Methodology**

This is implemented with both software and hardware using different tools as

- 1) Software
  - a) Keil TOOLS by arm version 4
  - b) Proteus
- 2) Hardware
  - a) Finger print module
  - b) ARM processor
  - c) LCD Display

2) Search of registered voter

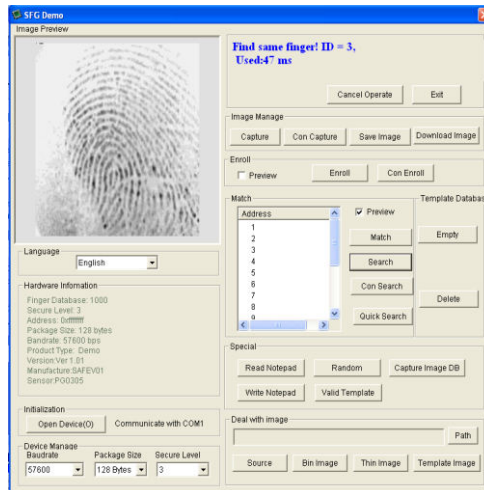

Fig. 4. Presearch of the registering user

*B. Voting*



Fig. 6. Fingerprint identification

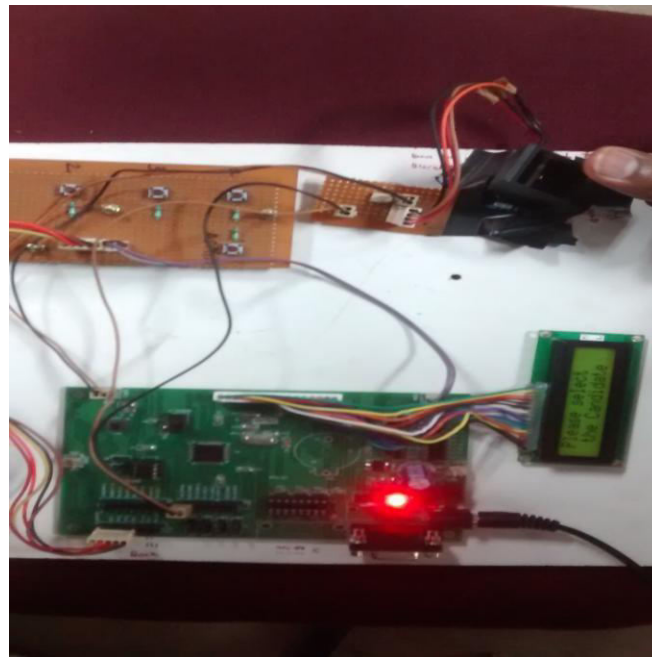

Fig. 7. Vote casting

1) *Display after the vote casting*



Fig. 8. Vote being accounted

2) *On the attempt of re-voting by the same person*

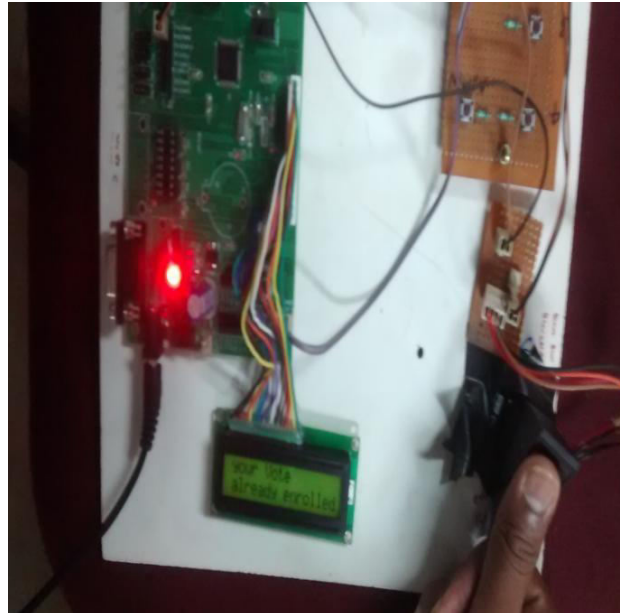

Fig. 9. Preventing of re-vote by the same user



3) Voting attempt by unregistered users

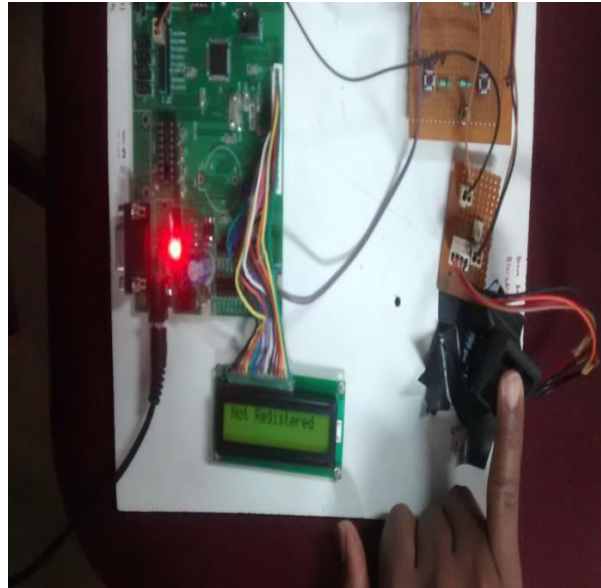

Fig. 10. Unregistered Voter

4) Results viewed by the Admin :

- It is economical
- Less manpower required
- Time conscious, less time required for voting & counting
- Avoids invalid voting as it prevents unregistered voters from voting.
- Ease of transportation due to its compact size.
- Convenient on the part of voter.

B. Disadvantages

- Before voting the user has to enroll first.
- Sensitivity of finger print module causes sometimes Combine character error.

## V.APPLICATIONS

This project can be used as a voting machine to prevent rigging, during the elections in the polling booths.

- Fast track voting which could be used in small scale elections, like resident welfare association, “panchayat” level election and other society level elections, where results can be instantaneous.
- It could also be used to conduct opinion polls during annual shareholders meeting.
- It could also be used to conduct general assembly elections where number of candidates are less than or equal to eight in the current situation, on a small scale basis.

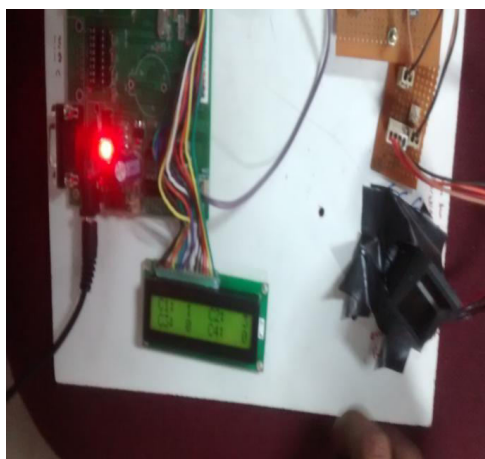

Fig. 11. Results retrieved by the Admin

## ADVANTAGES AND DISADVANTAGES

### A. Advantages

- Cost effective
- This system allows only authenticated voting than the existing equipment as the person is identified based on his Fingerprint which is unique to each individual.
- Low power consumption

## VI. CONCLUSION

The project "Fingerprint Based Voting Machine" was mainly intended to develop a fingerprint based advanced Electronic Voting Machine (EVM) which helps in free and fair way of conducting elections which are basis for democratic country like India.

## REFERENCES

- [1] Balaji, Speech of Shri V S Sampath, CEC for Defence Estates Day Lecture 2014
- [2] R. Haenni, E. Dubuis, and U. Ultes-Nitsche, "Research on e-voting technologies." Bern University of Applied Sciences, Technical Report 5, 2008.
- [3] G.V.L. N. Rao. Democracy at Risk! Citizens for Verifiability, Transparency & Accountability in Elections, New Delhi,
- [4] Election Commission of India.
- [5] A. K. Agarwala, D. T. Shahani, and P. V. Indiresan. Report of the expert committee for evaluation of the upgraded electronic voting machine (EVM). Sept. 2006.
- [6] Wikipedia. Results of the 2009 Indian general election by parliamentary constituency Sanjay Kumar, Manpreet Singh, "DESIGN OF A SECURE ELECTRONIC VOTING SYSTEM USING FINGERPRINT TECHNIQUE", IJCSI International Journal of Computer Science Issues, Vol. 10, Issue 4, No 1, July 2013
- [7] Press Trust of India.



INTERNATIONAL  
STANDARD  
SERIAL  
NUMBER  
INDIA



# INTERNATIONAL JOURNAL OF INNOVATIVE RESEARCH

IN COMPUTER & COMMUNICATION ENGINEERING

 9940 572 462  6381 907 438  [ijircce@gmail.com](mailto:ijircce@gmail.com)



[www.ijircce.com](http://www.ijircce.com)

Scan to save the contact details