



IJIRCCCE

e-ISSN: 2320-9801 | p-ISSN: 2320-9798



INTERNATIONAL JOURNAL OF INNOVATIVE RESEARCH

IN COMPUTER & COMMUNICATION ENGINEERING

Volume 12, Issue 5, May 2024

ISSN INTERNATIONAL
STANDARD
SERIAL
NUMBER
INDIA

Impact Factor: 8.379

 9940 572 462

 6381 907 438

 ijircce@gmail.com

 www.ijircce.com

Atmospheric Dust Collector Using IOT

T. Thirunavukkarasu, Nandhini A, Priyadharshini T, Rithika P, Deepika S

Assistant Professor, Department of ECE, R P Sarathy Institute of Technology, Salem, Tamil Nadu, India

Department of ECE, R P Sarathy Institute of Technology, Salem, Tamil Nadu, India

Department of ECE, R P Sarathy Institute of Technology, Salem, Tamil Nadu, India

Department of ECE, R P Sarathy Institute of Technology, Salem, Tamil Nadu, India

Department of ECE, R P Sarathy Institute of Technology, Salem, Tamil Nadu, India

ABSTRACT: The dust collector prototype represents an innovative solution for real-time air quality monitoring and dust particle collection, integrating advanced sensors, motor control, and IoT capabilities. By combining these elements, the system offers a comprehensive approach to environmental monitoring, enabling continuous data collection and analysis. Performance optimization strategies focus on sensor calibration, airflow dynamics, and power efficiency, ensuring accurate and reliable operation in diverse environmental conditions. Integration with drone technology further extends the system's reach, enabling remote monitoring and data collection in hard-to-reach areas. Through iterative improvement processes and careful deployment considerations, the prototype aims to provide actionable insights into air quality, facilitating informed decision-making and proactive environmental management. Overall, the dust collector prototype represents a promising advancement in air quality monitoring technology, with potential applications in various industries and settings. Atmospheric dust collectors play a critical role in maintaining air quality and reducing particulate matter pollution. This abstract provides an overview of the design, function, and effectiveness of atmospheric dust collectors. These devices utilize various mechanisms such as filtration, electrostatic precipitation, and cyclonic separation to capture dust particles from the air. Key factors influencing their performance include airflow velocity, particle size distribution, and filter efficiency. Advances in material science and engineering have led to the development of more efficient and compact dust collection systems, capable of handling a wide range of particulate pollutants. Understanding the principles underlying atmospheric dust collection is essential for designing effective air purification systems and mitigating the adverse effects of airborne pollutants on human health and the environment.

I. INTRODUCTION

In today's world, air pollution and indoor air quality have become significant concerns affecting health and well-being. The Dust Collector Prototype project aims to address these issues by providing a versatile and efficient solutions for monitoring dust levels and improving air quality in various environments. This documentation serves as a comprehensive guide for building, testing, and deploying the dust collector prototype. The purpose of this documentation is to provide detailed instructions and insights into the development process of the dust collector prototype. From the initial hardware setup to the software configuration, testing, and integration with drone technology, each aspect of the project is thoroughly explained to enable replication and customization by individuals or organizations interested in similar initiatives. Additionally, this documentation aims to foster understanding and awareness of air quality monitoring techniques and IoT applications. The scope of the dust collector prototype project encompasses the design, construction, and deployment of a functional device capable of detecting and mitigating dust particles in the air. Key components include the Sharp GP2Y1010AU0F Dust Sensor for accurate dust detection, an ESP32 microcontroller for data processing and communication, and motorized fan system for air circulation. Integration with the Blynk IoT application enables remote monitoring and control of the device, while potential integration with drone technology extends its reach and applicability. The significance of the dust collector prototype project lies in its potential to contribute to environmental monitoring efforts and public health initiatives. By providing real-time data on air quality and dust levels, the prototype empowers individuals, communities, and authorities to make informed decisions regarding indoor and outdoor environments.

II. LITERATURE SURVEY

1. Dr. Qiang (Chong) Zhang, P.Eng, Professor "Design Analysis Of Dust Collection System", Institute Of Electrical And Electronics Engineers :Most of the manufacturing industry faces significant challenges in the control of dust to ensure continued sustainable operation and to meet emissions regulations and goals. The methods for controlling dust

emissions can either lie in the prevention of dust emissions or in the removal of dust once it has become airborne. Though the concept for dust collection system seems simple, many things can go wrong if don't pay careful attention to the design details. Dust control systems involve multiple engineering decisions, including the efficient use of available space, the length of duct runs, the ease of returning collected dust to the process, the necessary electrical requirements, and the selection of optimal filter and control equipment.

2. M. Popa, O. Prostean and A.S. Popa(2013), "Analysis of Design and Purchase Decision of Central Dust Collection System", Institute of Electrical and Electronics Engineers :This paper presents a better solution for wood dust collection and consumer understanding for the purchase decision making of the central dust collection system in case of Bangladeshi Furniture Industries. Dust collection system is an integral part of furniture industries where quality products, proper safety, operations and maintenance are sought. An efficient woodworking dust collection system is a priority for furniture industries to maintain their business. The greatest source of problems with dust collection systems is improperly designed ducting and hood arrangements.

3.Laurent¹, R. Losno^{1,a}, S.Chevallier¹, J. Vincent¹, P. Rouillet², E. Bon Nguyen¹, N. Ouboulmane¹, S. Triquet¹, M. Fournier³, P. Raimbault³, and G. Bergametti¹, An automatic collector to monitor insoluble atmospheric deposition; application for mineral dust deposition Institute of Electrical and Electronics Engineers: Deposition is one of the key terms of the mineral dust cycle. However, dust deposition remains poorly constrained in transport models simulating the atmospheric dust cycle. This is mainly due to the limited number of relevant deposition measurements. This paper aims to present an automatic collector (CARAGA), specially developed to sample the total (dry and wet) atmospheric deposition of insoluble dust in remote areas. The autonomy of the CARAGA can range from 25 days to almost 1 year depending on the programmed sampling frequency (from 1 day to 2 weeks respectively). This collector is used to sample atmospheric deposition of Saharan dust on the Frioul islands in the Gulf of Lions in the Western Mediterranean.

4. S. Ketkaew, Air Cleaner by Using High Voltage Electrostatic", Institute of Electrical and Electronics Engineers:This paper presents a study of design and construction of Air Cleaner by Using High Voltage Electrostatic with 126 m³/hr recirculated air capacity for a 15 m³ room. By applying the working of switching circuit that control the voltage of flyback transformer code TLF 146491. It can make energized with potential up to 8.0 kV and 4.0 kV for ionization section and dust collecting. It has been designed to remove dust or small particles with diameter in the range 0.01 micrometer up to 200 micrometer. The simulation test result which have been done by drawing dust, the joss stick and tobacco smoke through the until have proven that the air clean can trap these dust and smoke. And it can protect the hazard from current that effect to the workers. So it is installed switch for Discharging in Electrostatic.

5. Rohit D. Gawade and S. L. Nalbalwar (2016), Dust Collection System Design", Institute of Electrical and Electronics Engineers: Decor Cabinet Company is a leading North American cabinet manufacturer based in Morden, Manitoba. It produces wooden cabinets for a variety of kitchen styles. Each kitchen is custom made with many different personal finishes to choose from. Decor has two production facilities in Morden that are used to manufacture cabinets. The smaller facility, as seen in Figure 1, houses cabinet door production, and the larger facility houses other manufacturing processes such as cabinet assembly and finishing. Our project focuses on the cabinet door manufacturing. The machines in this manufacturing facility produce dust and wood chips while in operation. The debris is currently removed using a dust collection system.

6 .Hengxin Zhong, A structure of movable dust collector on the principle of air amplification", Institute of Electrical and Electronics Engineers:Currently, with the national advocacy of the application of green energy resource, solar energy has been widely used as an extremely important clean energy resource. Among them, solar panels as a key component of the use of solar energy will accumulate a lot of dust in the case of lifetime service, resulting in a decline in the service life and efficiency of solar panels. Therefore, the design of an effective cleaning plant is imperative. First of all, the design of the cleaning plant structure in this paper is based on the principle of simple structure, high cost performance and at the same time, it realizes the one-to-many movable regular cleaning of solar panels which can effectively reduce the influence of dust on solar panels.

7. M.Patel, Project on Dust Collector (LCIT Bhandu)", Institute of Electrical and Electronics Engineers:The trend among pharmaceutical companies to develop selective drugs of high potency has pushed the industry to consider the potential of each hazardous ingredient to become airborne. Dustiness issues are not unique to the pharmaceutical industry, but are relevant to any industry where powdered materials are mixed, transferred and handled. Interest in dustiness is also driven by concerns for worker health, the potential for plant explosions and the prevention of product loss. Unlike other industries, the pharmaceutical industry is limited by the milligram quantity of powdered material

available for testing during product development. These needs have led to the development of a bench top dustiness tester that requires only 10mg of powder and fully contains the generated aerosol.

III. PROBLEM STATEMENT

The problem statement for an atmospheric dust collector typically revolves around the need to mitigate airborne particulate matter pollution. This encompasses various challenges, including:

Health Risks: Airborne dust particles can pose significant health risks, such as respiratory problems, allergies, and cardiovascular issues, especially for vulnerable populations like children and the elderly.

Environmental Impact: Dust pollution contributes to environmental degradation by affecting soil quality, water bodies, and vegetation, leading to ecosystem imbalance and biodiversity loss.

Industrial Emissions: Industrial activities, construction, transportation, and agricultural operations generate substantial amounts of airborne dust, exacerbating pollution levels in urban and rural areas.

Regulatory Compliance: Compliance with air quality standards and regulations necessitates effective dust control measures, requiring industries and municipalities to invest in efficient atmospheric dust collection systems.

Technological Limitations: Existing atmospheric dust collectors may have limitations in terms of efficiency, scalability, energy consumption, maintenance requirements, and adaptability to varying particulate matter compositions and concentrations.

IV. INTERNET OF THINGS

The Internet of Things (IOT) is an important topic in technology industry, policy, and engineering circles and has become headline news in both the specialty press and the popular media. This technology is embodied in a wide spectrum of networked products, systems, and sensors, which take advantage of advancements in computing power, electronics miniaturization, and network interconnections to offer new capabilities not previously possible. An abundance of conferences, reports, and news articles discuss and debate the prospective impact of the “IOT revolution”— from new market opportunities and business models to concerns about security, privacy, and technical interoperability.

IOT systems like networked vehicles, intelligent traffic systems, and sensors embedded in roads and bridges move us closer to the idea of “smart cities”, which help minimize congestion and energy consumption. IOT technology offers the possibility to transform agriculture, industry, and energy production and distribution by increasing the availability of information along the value chain of production using networked sensors. However, IOT raises many issues and challenges that need to be considered and addressed in order for potential benefits to be realized.

V. PROPOSED SYSTEM

The Dust Collector Prototype represents a novel approach to monitoring and improving air quality in various environments. Designed to detect and mitigate dust particles suspended in the air, the prototype integrates cutting-edge sensor technology, microcontroller functionality, and IoT capabilities to provide real-time data insights and actionable information. By employing a combination of hardware and software components, the prototype offers a versatile solution for addressing air pollution concerns and promoting healthier living and working environments.

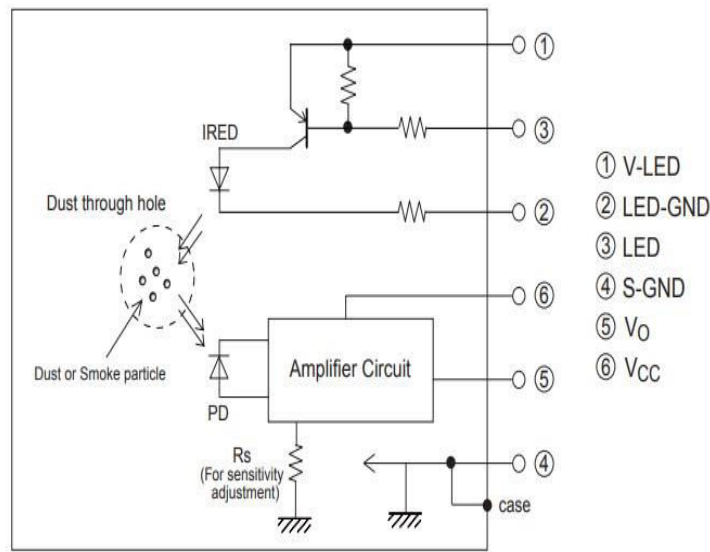

Figure 1. Sharp GP2Y1010AU0F Dust Sensor

VI. SYSTEM MODEL

6.1 Hardware Requirements

- ESP32 Microcontroller
- MQ-135 Gas Sensor
- SHARP GP2Y1010AU0F Dust Sensor
- Dust sensor

6.2 Software Requirements

- Blynk App

VII. EXPERIMENTAL RESULT

The development and deployment of the dust collector prototype represent a significant step forward in addressing air quality concerns and promoting environmental health and safety. Through the integration of sensor technology, microcontrollers, and drone technology, the prototype offers a versatile and effective solution for monitoring air quality, detecting dust particles, and assessing environmental conditions.

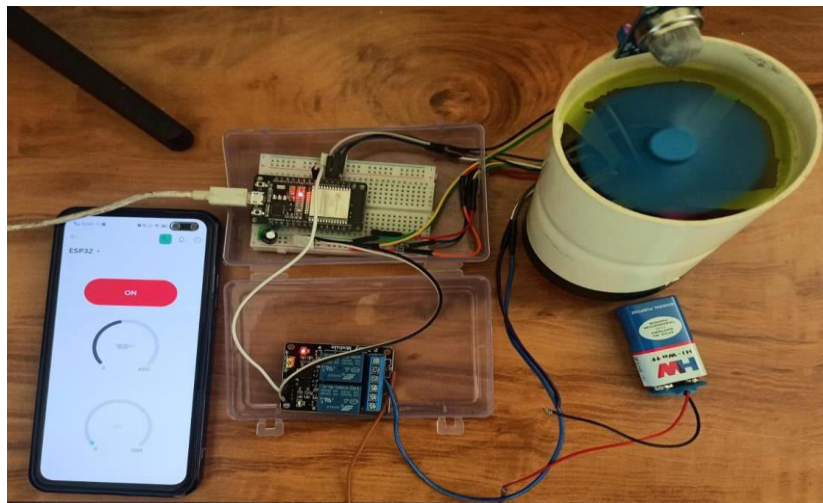

Figure .2 Dust collection System

VIII. CONCLUSION

In summary, integrating IoT technology with atmospheric dust collectors offers unparalleled benefits in real-time monitoring, remote control, and data-driven decision-making. This synergy enhances operational efficiency, reduces maintenance costs, and improves overall air quality management. By harnessing the power of IoT, atmospheric dust collectors become smarter, more adaptable, and more effective tools for environmental protection and industrial safety, ushering in a new era of intelligent dust control solutions.

REFERENCES

1. Available from American Conference of Governmental Industrial Hygienists, 1330 Kemper Meadow Drive, Cincinnati, OH 45240; 513-742-6163, <http://www.acgih.org>
2. Andrew, C., O. Andrew, S. Joseph, and C. Jay F. 2012. Dust Control Handbook for Industrial Minerals Mining and Processing.
3. Bhuiyan, M. Y., and A. I. Khan. 2012. Analysis of design and purchase decision of central dust collection system 13: 410414.doi:10.1109/imws.2011.6114972.
4. Buczaj, M., and A. Buczaj. 2012. The use of lab view environment for the building of the grain Dust control system in grain mill.
5. Hollenbeck, P. 2015. The a-curve position from an aaberg exhaust hood. Ventilation 2015 -Proceedings of the 11th International Conference on Industrial Ventilation 2: 575–582.Industrial Ventilation Manual. 1998. ACGIH: Industrial Ventilation Manual. Vol. 552.
6. Jenike, E. M., and Johanson. 2018. SIX KEY CONSIDERATIONS FOR PROPER DUST COLLECTION. CSC Publishinh.
7. Johnson Q. G., “Designing your dust collection to meet NFPA standards-Part I”, Workplace Exposure Solutions, Powder and Bulk Engineering, December 2008, PP 4-5.
8. Johnson, G. 2008. Designing your dust system collection to meet NFPA Standards- Part 1. PBE.
9. Kleinman, J., and D. Marley. 2005. Savings estimates for dust collection system controls: Strategies used and lessons learned. Proceedings ACEEE Summer Study on Energy Efficiency in Industry: 108–118.
10. Mcfadden and Joanne, “Dust-collection units increase productivity, worker satisfaction,” Published in The Business Review journal, 2002.



INTERNATIONAL
STANDARD
SERIAL
NUMBER
INDIA



INTERNATIONAL JOURNAL OF INNOVATIVE RESEARCH

IN COMPUTER & COMMUNICATION ENGINEERING

 9940 572 462  6381 907 438  ijircce@gmail.com



www.ijircce.com

Scan to save the contact details