



International Journal of Innovative Research in Computer and Communication Engineering

(An ISO 3297: 2007 Certified Organization)

Vol. 2, Issue 1, January 2014

Performance Evaluation of Conventional Controller for Positive Output Re Lift LUO Converter

Sivakumar.A¹, Ajin Sekhar.S.C², Ronal Marian.A³, Sasikumar.M⁴

P.G.Scholar, Dept of Power Electronics and Drives, Jeppiaar Engineering College, Chennai, India

P.G.Scholar, Dept of Power Electronics and Drives, Jeppiaar Engineering College, Chennai, India

Assistant Professor, Dept of Electrical & Electronics Engg, Sri Raja Rajan College of Engg, Karaikudi, India

Professor & Head, Dept of Power Electronics and Drives, Jeppiaar Engineering College, Chennai, India

ABSTRACT: Faster development in Dc to Dc converter techniques are undergoing very drastic changes due to that major advancements like low voltage, high power density in electronic industry. The positive output Relift LUO converter is a novel Dc to Dc voltage gain converter, which uses voltage lift technique for the conversion of positive input source voltage to positive output load voltage. Complex behaviour characteristics like nonlinear and time variant make the converter works in switch mode. The main aim of this paper to model and analyze proportional integral controller for positive output Relift LUO converter. control circuit for the positive output Relift converter is implemented with the help of PI controller by using MATLAB/simulink. PI control for positive output Relift LUO converter is tested for transient region, line changes, load changes, steady state region. for both static and dynamic specifications dynamic performance of the positive output Relift LUO converter is validated.

Keywords: DC-DC converter, Matlab, positive output Relift LUO converter, Proportional Integral control simulink

I. INTRODUCTION

The positive output Relift LUO converter gives the voltage gain in terms of arithmetic progression instead of geometric progression of conventional Dc to Dc converters. The main objective is to reach high efficiency, high power density and cheap topology in a simple structure. Due to the effect of parasitic elements, the output voltage and power. Transfer efficiency is restricted in DC –DC converter. The voltage-lift technique is a popular method that is widely applied in electronic circuit design. It can open a good way of improving DC-DC converters characteristics and has been successfully applied for DC-DC converters. Traditional frequency-domain analog methods predominantly used in controller design are based essentially on an equivalent linear small-signal model of the converter concerned. Under line and load disturbances the output voltage of the converter is regulated with the help of development PI controller. stability, large line and load variation robustness, good dynamic response are the essential features of PI control technique. fast dynamic response for line side and load side disturbances with output voltage regulation is used to ensure the choice of specific PI controller. Zero steady state error and fast response is brought forward with PI control. a good alternative to the control of switching power converters is implemented with PI control a PI control is a more feasible approach to ensure the correct operation in any working condition to optimize the stability of positive output Relift LUO converter. PI control for negative output Re lift LUO converter is studied in Matlab/Simulink is evaluated for the performance of both static and dynamic performance.

II. RELATED WORK

In [1] used voltage lift technique for DC-DC converters, Converters which eliminates the auxiliary switch in the original Positive Output Luo-Converters yet perform the same functions. They are different from any other existing DC-DC step-up converters and possess many advantages including the high output voltage with smooth ripples.

In [2] Proposes a PI controller positive output elementary LUO converter The object of this paper is to design and analyze a proportional – integral (PI) control for positive output elementary super lift Luo converter (POESLLC), which is the start-of-the-art DC-DC converter. Using state space average method derives the dynamic equations

International Journal of Innovative Research in Computer and Communication Engineering

(An ISO 3297: 2007 Certified Organization)

Vol. 2, Issue 1, January 2014

describing the positive output elementary super lift Luo converter and PI control is designed. In [4] introduces the voltage-lift technique using voltage-lift circuit has been successfully applied to several series of DC-DC Luo converters. However, the voltage-lift circuit definitely has an unavoidable influence on the overall converter performance. It is attempted to clarify such an effect. Four converters with voltage-lift circuit are analysed: positive output self-lift Luo converter, positive output super-lift converter, negative output self-lift Luo converter and positive output re-lift Luo converter. In [5] proposes the new advanced converter if re lift LUO converter. A re-lift circuit, which is a new DC-DC step-up (boost) converter, is proposed. This converter performs positive to positive DC-DC voltage increasing conversion with high output voltage. The voltage lift technique is a technique applied in lifting the output voltage without using any external circuit, just by using the passive components. In [6] propose positive output LUO converters in Hand book of Power electronics. The Positive output (N/O) Luo-converters performs voltage conversion from positive source to positive load voltages using the voltage-lift technique. They work in the First quadrant with large voltage amplification, and their voltage-transfer gain is high. Double output Luo-converters perform the voltage conversion from positive to positive and negative voltages simultaneously using the voltage-lift technique. They work in the first and third quadrants with large voltage amplification, and their voltage-transfer gain is high. Based on the Positive Output Luo-Converters and Negative Output Luo-Converters.

III. LUO CONVERTERS

The elementary LUO converter performs buck or boost operation in Dc to Dc conversion. The positive output LUO converter performs the conversion from positive input source voltage to positive output load voltage. Self-lift, Re lift, triple-lift, quadruple-lift and super-lift converters are the types of LUO converters which are derived from their appropriate elementary circuits with the help of voltage lift techniques. Reduction of value of duty ratio as well as effect of parasitic elements can be easily acquired by the voltage lift technique. Luo converters have the characteristics of high voltage transfer gain, high power density, and reduced ripple in voltage and current in simple topology.

A. Positive Output LUO Re-lift Converter

The positive output Relift converter circuit is shown in fig 1. It consists of two MOSFET switches namely S, S₁, three inductors L₀, L₁, L₂, four capacitors C, C₁, C₂, C₃ and the diodes D₁, D₂, D₃. The positive output re-lift LUO (PORLL) converter has two voltage lift circuits and the converter is shown in Fig. 1. Compared with the PORLL converter, an extra VLC, which consists of a capacitor C₂ and a diode D₂, is added to the circuit. Another switch S₁ is implemented, as shown in the Figure. It is turned on and off at the same time as the switch S. Two capacitors, C₁ and C₂, are the same. The equivalent circuits of the PORLL converter during switch-on and switch-off periods are shown in and, respectively. It shows the equivalent circuit when the converter operates in DCM.

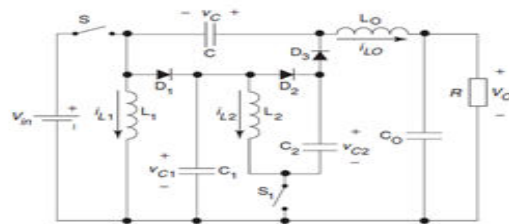

Fig.1. Positive Output Relift LUO Converter

During switch-on period, the voltages across the two inductors L₁ and L₂ are the same, which is equal to the input voltage V_{in}. Capacitors C₁ and C₂ are charged rapidly to the source voltage V_{in}. The average voltage of the pump capacitor C, V_c, is also equal to the output voltage V_o and it is discharged with current i_{L0}. The average value of the voltage across the inductor L₀ is also equal to source voltage during this period because V_c is equal to V_c.

International Journal of Innovative Research in Computer and Communication Engineering

(An ISO 3297: 2007 Certified Organization)

Vol. 2, Issue 1, January 2014

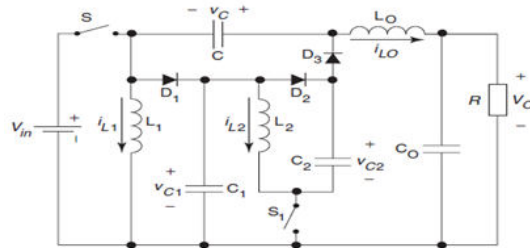

Fig.2.Positive Output Relift LUO Converter in ON Condition

According to Fig. 3, switch-off period current i_{L1} and i_{LO} flow through inductor L_2 during. As the inductor current i_{L2} cannot be changed discontinuously, the current difference between $i_{L2}(kT)$ and $i_{L1}(kT) + i_{LO}(kT)$ should flow through the diode D_2 until the difference is zero. Avoid this problem, it should be maintained that

$$i_{L2}(kT) = i_{L1}(kT) + i_{LO}(kT)$$

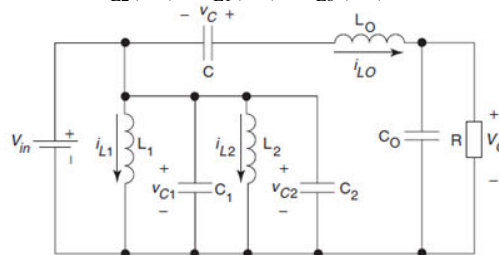

Fig.3.Positive Output Relift LUO Converter in OFF Condition

The switch is ON for period kT and OFF for $(1-k)T$ period. The output voltage and current are

$$V_0 = \frac{1-K}{2} V_I \quad (1)$$

And

$$V_0 = \frac{1-K}{2} I_I$$

The voltage transfer gain in continuous mode is

$$\begin{aligned} M_T &= \frac{V_0}{V_I} \\ &= \frac{2}{1-K} \end{aligned} \quad (2)$$

Average current

$$I_{LO} = I_O = \frac{V_0}{R} \quad (3)$$

The Current through Inductor L_1 is

$$I_{L1} = \frac{2}{1-k} I_i \quad (4)$$

The Current through Inductor L_2 is

International Journal of Innovative Research in Computer and Communication Engineering

(An ISO 3297: 2007 Certified Organization)

Vol. 2, Issue 1, January 2014

$$I_{L2} = \frac{2}{1-k} I_1 \quad (5)$$

IV. DESIGN OF PI CONTROLLER

The nominal operating point for positive output Relift LUO converter can be achieved desired specific PI control, so that sudden load, disturbances and set point variations stays are very closer to the nominal operating point. With the help of Zeigler – Nichols tuning method proportional gain (K_p) and integral time (T_i) are designed by applying the step test obtain S – shaped curve of step response of PORLLC. Which may be may be characterized by two constants, delay time and time constant. The delay time is computed by drawing a tangent line at the inflection point of the S-shaped curve. Intersections of the tangent line with line output response and Time axis the value of time constant is calculated. With the help of Zeigler – Nichols tuning method proportional gain (K_p) and integral time (T_i) are designed from the above calculated value.

$$U(t) = K_p \left[e(t) + \frac{1}{T} \int_0^t e(\tau) d\tau \right]$$

V. SIMULATION OF RE LIFT LUO CONVERTER

The simulation has been performed on the positive output Relift lift LUO converter circuit with parameters listed in Table I, Simulation Circuit was shown in Fig 4. The static and dynamic performance of PI control for the positive output re lift LUO converter is evaluated in Matlab/Simulink

Table 1: Specification of circuit parameters

| Parameters | Specification |
|----------------------------|---------------|
| Input voltage V_1 | 12V |
| Output voltage V_2 | 72V |
| Load resistance R_L | 250Ω |
| Switching frequency f_s | 20 kHz |
| Resonant capacitor C_r | 20 μF, 2.2 μF |
| Inductors L_{r1}, L_{r2} | 1 mH, 0.5mh |

The difference between feedback output voltage and reference voltage is given to PI control and output of PI control, change in duty cycle of the power switch (n - channel MOSFET).

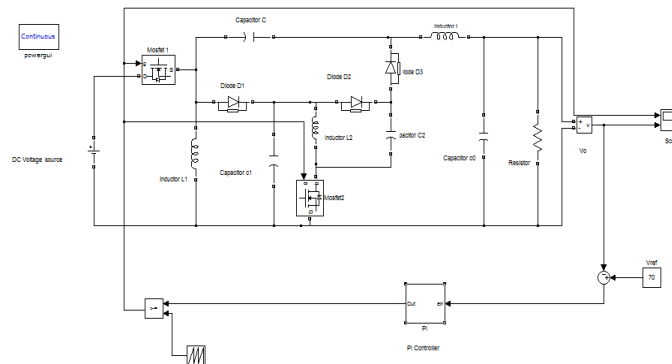

Fig.4.Simulink Diagram of Positive Output Relift LUO Converter With PI Controller

The positive output Re lift LUO converter performance is done for transient region, line variations and load variations
Copyright to IJIRCE www.ijirce.com 2602

International Journal of Innovative Research in Computer and Communication Engineering

(An ISO 3297: 2007 Certified Organization)

Vol. 2, Issue 1, January 2014

A. Transient Region

The Figure 5 Shows the Output Voltage of Positive Output Relift LUO Converter with PI Control in Transient Region, Which Shown that the Output Voltage Settled at 0.016sec for the specified PI Control.

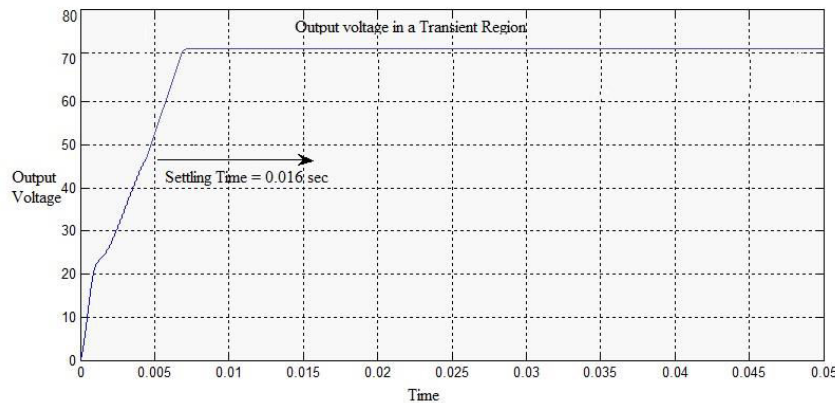

Fig.5.Output Voltage in Transient Region

B. Supply Disturbances

With supply variation of +5V

Fig.6 shows the output voltage of converter for input voltage step change from 12 V to 17 V (+5v supply disturbance).the converter output voltage has maximum overshoot of 4V and 0.003sec settling time with designed PI control. Fig.7 shows the output voltage variations for the input voltage step change from 12 V to 9 V (-5V supply disturbance).the converter output voltage has maximum overshoot of 2 V and 0.003 sec settling time with designed PI control

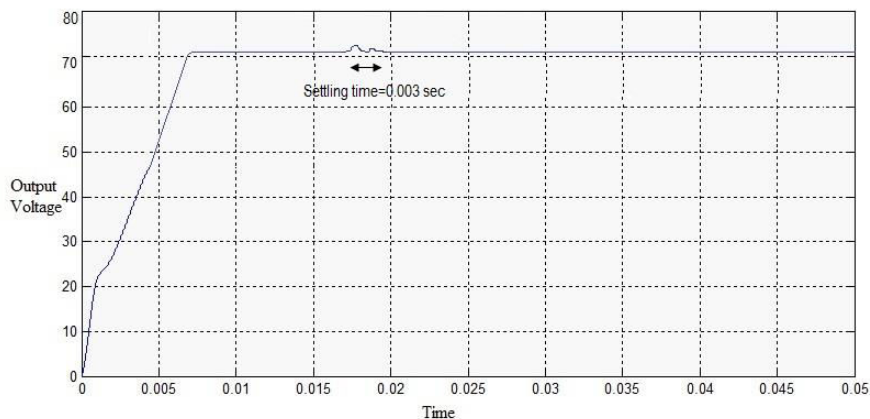

Figure 6 Output voltage - supply change from 12 V to 17 V

With supply variation of -5V

International Journal of Innovative Research in Computer and Communication Engineering

(An ISO 3297: 2007 Certified Organization)

Vol. 2, Issue 1, January 2014

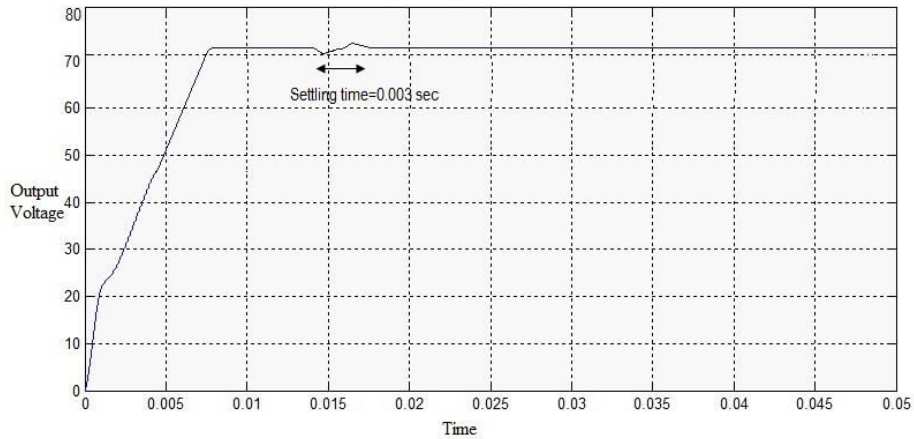

Figure 7 Output voltage - supply change from 12 V to 7 V

C.Load Disturbance

With load change of 20%

Fig.8 shows the output voltage with change the load from 250 Ω to 200 Ω (-20% load disturbance).the maximum overshoot is 0.6 V and settled at the 0.005 sec .Fig.9 shows the variation of load from 250 Ω to 275 Ω (+20% disturbance) the maximum overshoot of 0.003 V and settled at 0.00 sec.

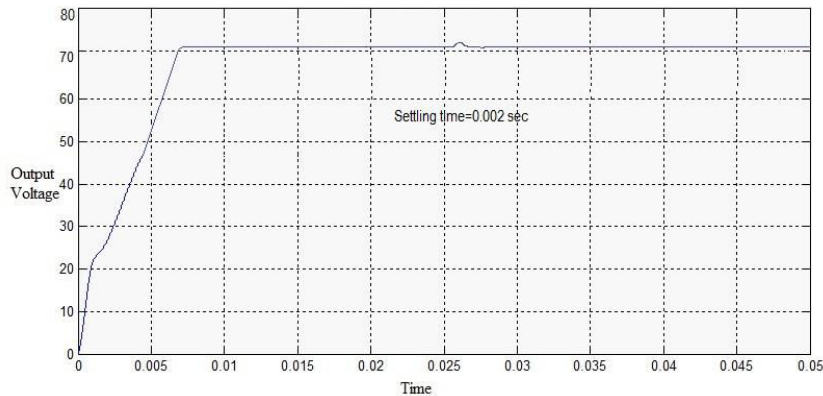

Figure 8 output voltage – load change from 250 Ω to 200 Ω

With load change of 20%

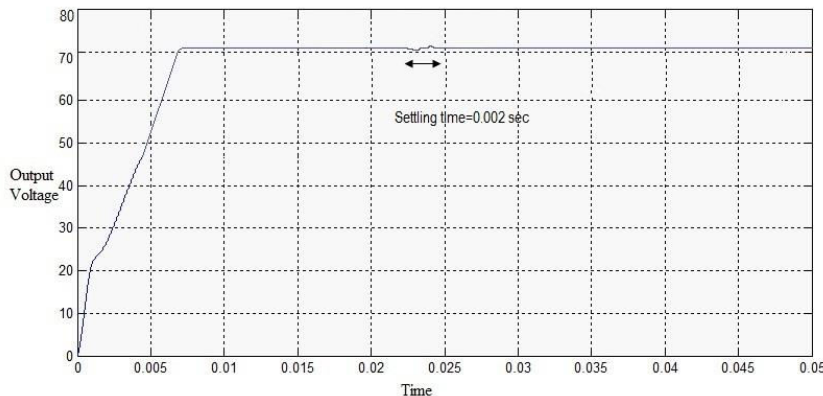

Figure 9 output voltage – load change from 250 Ω to 300 Ω

International Journal of Innovative Research in Computer and Communication Engineering

(An ISO 3297: 2007 Certified Organization)

Vol. 2, Issue 1, January 2014

TABLE 2: PERFORMANCE EVALUATION OF PI CONTROLLER FOR POSITIVE OUTPUT RELIFT LUO CONVERTER WITH RESISTIVE LOAD USING MATLAB

| Delay time (msecs) | Rise time (msecs) | Peak over shoot (%) | Start up Transient | | Line Disturbance | | | | Load disturbance | | | |
|--------------------|-------------------|---------------------|--------------------|-----------------------|---------------------|-----------------------|---------------------|-----------------------|---------------------|-----------------------|---------------------|-----------------------|
| | | | Peak time (msecs) | Settling time (msecs) | Supply increase 10% | | Supply decrease 10% | | Load increase 10% | | Load decrease 10% | |
| | | | | | Peak over shoot (%) | Settling time (msecs) | Peak over shoot (%) | Settling time (msecs) | Peak over shoot (%) | Settling time (msecs) | Peak over shoot (%) | Settling time (msecs) |
| 0.39 | 1 | 11.3 | 1.77 | 1.6 | 9.2 | 4.6 | 7.7 | 3 | 1.95 | 3.4 | 1.91 | 3 |

VI.CONCLUSION

The Positive Output Relift lift LUO converter (PORLLC) performs the voltage conversion from positive source voltage to Positive load voltage. In this paper PI control scheme has proved to be robust and it has been validated with transient region, line and load variations for PORLLC. The Positive output re lift LUO converter with PI control use in applications such as switch mode power supply, computer peripherals and high voltage projects etc.

REFERENCES

1. Luo.F.L and Ye.H, "Positive output super lift converters," IEEE Transaction on power electronics, Vol.18, No. 1, pp. 105-113, January 2003.
2. Ramesh kumar.K and Jeevanantham.S." PI Control for positive output elementary super lift lu0 converter," World Academy of Science, Engineering and Technology. pp. 732-737, March 2010.
3. Kayalvizhi.R ,Natarajan.S.P and Padmaloshani.P" Development of a Neuro Controller for a Negative output Elementary Luo Converter" Journal of Power Electronics, Vol. 7, No. 2, April 2007
4. Luo, F.L. 1998. "Luo-Converters, Voltage Lift Technique". *Proceedings of the IEEE Power Electronics Specialist Conference IEEE PESC' 98*. Fukuoka, Japan, May 17- 22 1997. 1783-1789.
5. Luo F.L. 1998. "Re-Lift Converter: Design, Test, Simulation and Stability Analysis". *IEE – EPA Proceedings*. July 1988. 145(4):315-325.
6. Luo, F.L. 1997. "Re-Lift Circuit: A New DC-DC Step- up (Boost) Converter". *IEE - Electronics Letters*. 2nd January 1997.
7. Rashid.M.H Power Electronics Hand Book, ..Ed., Academic, San Diego, CA, Aug.2001.
8. Luo, F.L. 1997. "Luo-Converters: A Series of New DC-DC Step-up (Boost) Conversion Circuits". *Proceedings of IEEE International Conference PEDS'97*. 26-29 May 1997. Singapore. 582-588.
9. JosephBasanth,A ,Natarajan.S.P and Sivakumaran.T.S, Simulation and DSP based implementation of double output elementary lu0 converter, *International Conference PESA-09*, Hong Kong.

BIOGRAPHY



Mr. A.Sivakumar has received the Bachelor degree in Electrical and Electronics Engineering from Raja College of Engineering And Technology, Madurai, and Anna University India in 2012. He is pursuing Master of Engineering in Power Electronics and Drives from Jeppiaar Engineering College, Anna University, India. His Area of interest includes in the field of Solar PV Systems, Power Converters.



ISSN(Online): 2320-9801
ISSN (Print): 2320-9798

International Journal of Innovative Research in Computer and Communication Engineering

(An ISO 3297: 2007 Certified Organization)

Vol. 2, Issue 1, January 2014



Mr.C.S.Ajin Sekhar received the B.E degree in electrical and electronics engineering from SRR engineering College, Anna University, Chennai 2012, India, He is pursuing Master of Engineering in Power Electronics and Drives from Jeppiaar Engineering College, Anna University, India. Area of interest in the field of renewable energy.



A. **Ronald Marian** is currently pursuing the M.E Degree from Jeppiaar Engineering College, Anna University, and Chennai, India. Earlier he received his B.E degree in Electrical and Electronics Engineering in the same institution, India in 2011. His current research interests include Induction Motor Drives, Renewable Energy Sources, Multi level inverter, smc techniques and Z-Source Converters.



Dr.M.Sasikumar was born in Tamilnadu, India on June 17, 1977. He received the B.E degree in electrical and electronics engineering from K.S.Rangasamy College of Technology, Madras University, India in 1999, and the M.Tech degree in power electronics from VIT University, in 2006. He has obtained his PhD. degree from Sathyabama University, Chennai, and Tamilnadu, India. Currently, he is working as a Professor in Jeppiaar Engineering College, Anna University, and Chennai. He has 11 years of teaching experience. He has published over 30 technical papers in National and International Conferences /proceedings / journals. His research areas are power electronics drives and wind energy systems.