



Power Efficient Class AB Op-Amps with High and Symmetrical Slew Rate

Eswar Narayana, Vijaya Nirmala,

Department of ECE, Annamacharya Institute of Technology and Sciences, Kadapa, Andhra Pradesh, India

Professor & Head of the Department, Annamacharya Institute of Technology and Sciences, Kadapa, Andhra Pradesh, India

ABSTRACT: We introduced various class AB two stage op-amps with high and approximately symmetrical slew rate and very simple architecture are introduced. A combination of adoptive loads and current replicating branch with scaled-down transistors is used to implement a push-pull output stage with maximum output current several times higher than the bias current. post layout simulation and measurement results are presented and verify a 400%-500% slew rate and 80%-100%GB enhancement with only 5% additional quiescent power dissipation and 20% silicon area increase.

KEYWORDS: Symmetrical slew rate, operational amplifiers, class AB operation, gain, CMOS analog integrated circuits.

I. INTRODUCTION

In single-stage op-amps achieves highly symmetrical slew rate by using different efficient schemes. A drawback of a single stage op-amp is that relatively low open-loop gain(AOL).since the output cascading transistors is to increase the output resistances(R_{out}) would seriously limit the maximum output current and the slew rate enhancement factor .In the conventional class-A two-stage Miller-compensated op-amp is characterized by a highly asymmetrical slew rate with large positive slew rate and much lower negative slew rate .This lower negative-slew rate is due to the output transistor (MoN) acts as a dc current source with value $2I_B$ and increase the static power dissipation .To avoid this limitation many class AB two-stage op-amps have been reported. Most of them feature is relatively modest effective slew rate improvement and require additional complex circuitry, and non negligible additional static power dissipation or increased supply requirements. This decreases their current efficiency .In fig (b) achieves class AB operation with additional small hardware. It consists of a large resistive R large and small capacitor C bat This combination operates as a open battery that transfers ac variations taking place at the gate of Mop to the gate of Mon transistors .The output stage operates as a push-pull amplifier and provides dynamic class-AB operation with large positive and negative output currents. This does not increase power dissipation or supply requirements but operates only for dynamic changes with frequencies.

II. CLASS AB TWO-STAGE OP-AMPS PROPOSED

A.Op-Amp with Current Replication Branch

To achieve class AB operation, the output transistor MoN can be transformed into an active amplifying device by simply adding a current replicating branch formed by M2R and MoNR as shown in fig1(c).This transfers current variations I_a in M1-M2 to the output transistor MoN and increases and increases the maximum positive output current by $2I_B$.

The maximum negative current is still limited to a value of $2I_B$.The current replicating branch does not require additional compensation circuit. Since the node V_x with gain in the current replicating branch is gate to the drain of MoN, and at the higher frequencies miller compensation causes MoP to behave as low impedance load. This reduces the gain between the gate of MoN and the op-amps output terminal to closely a unity value. The current replicating branch has small dimensions reducing area and static power dissipation.

In order to achieve large negative output currents, a non-linear adoptive load can be used. This modification is seen in another circuit.

B. Class AB Two-Stage Op-Amp Using Adaptive Loads

By using an adaptive load at the input side in the circuit we can achieve class AB operation efficiently. Two different alternatives are shown in fig (d) and fig (e). In both cases, the adoptive loads manoeuvre the large variation of output resistance of transistors between triode and saturation regions in quiescent conditions. In both schemes a current increase in IA causes transistors to go in triode region and to develop large drain-source voltages. These changes cause large currents flow in the output transistors Mop and thanks to the current replicating branch, MoN.

A bias voltage with value $V_{b\text{ triode}} = V_{ss} + V_{gs} + V_{DSsat} = V_{TH} + 2V_{DSsat}$ is required at the gate of MoNR. Where $V_{DSsat} = V_{gs} - V_{th}$ is the minimum Vds voltage to operate in saturation region. This $V_{b\text{ triode}}$ leaves a quiescent drain-source voltage for MoNtriode with value V_{DSsat} , which causes MoNtriode to operate at the boundary between the triode and saturation regions.

The circuit of fig (2) is denoted as operational amplifier with current replicating branch and adaptive loads. These topologies are not harmful in terms of stability of the ac responses. The current replicating branch helps compensating the current through the miller capacitor just as in other multipath miller zero-cancellation scheme.

III.SIMULATION RESULTS

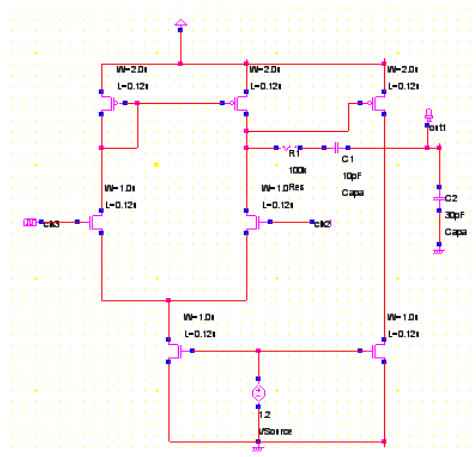

Fig 1(a) .Schematic of Conventional class A two-stage miller op-amp

Organized by

Dept. of ECE, Annamacharya Institute Of Technology & Sciences, Rajampet, Andhra Pradesh-516126, India held on 28th February 2015

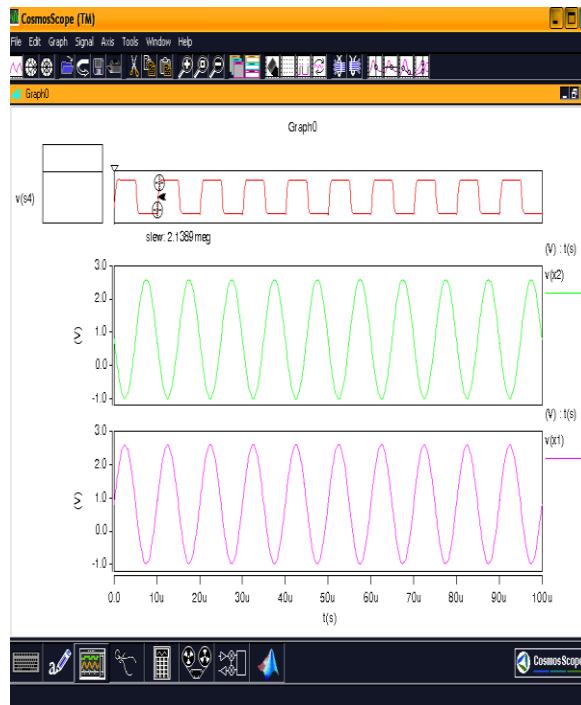

Fig 1(b). Output result Conventional class A two-stage miller op-amp

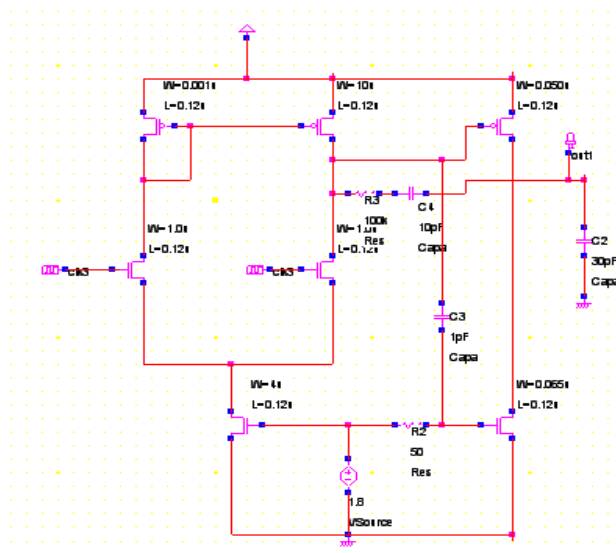

Fig 2(a).Schematic of free class AB op-amp

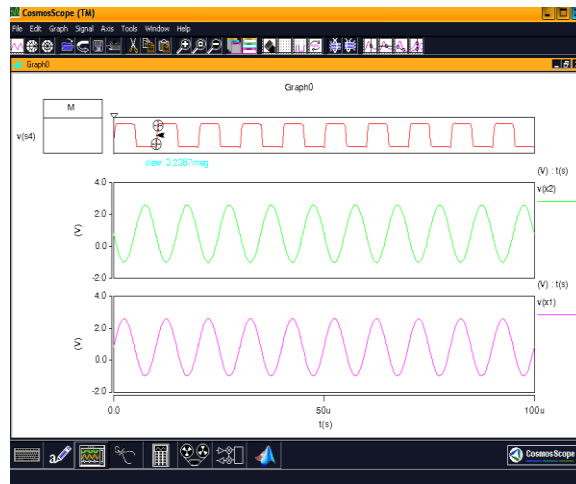

Fig 2(b).Output waveform free class AB op-amp

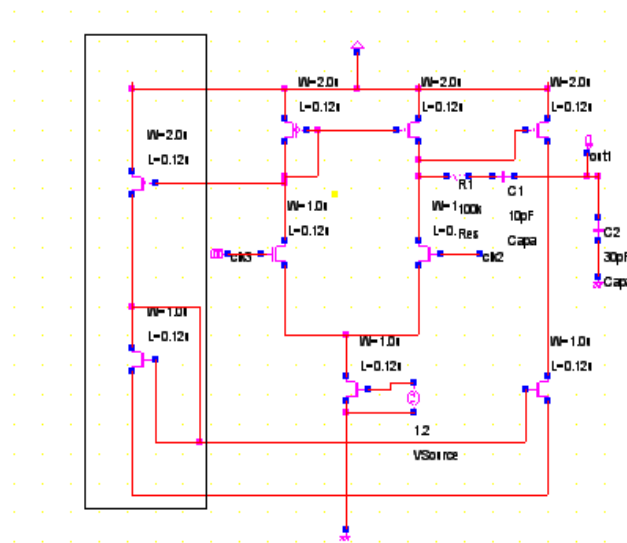

Fig 3(a) Schematic of push pulls op-amp with current replication branch.

Organized by

Dept. of ECE, Annamacharya Institute Of Technology & Sciences, Rajampet, Andhra Pradesh-516126, India held on 28th February 2015



Fig 3(b).Output waveform of push pulls op-amp with current replication branch

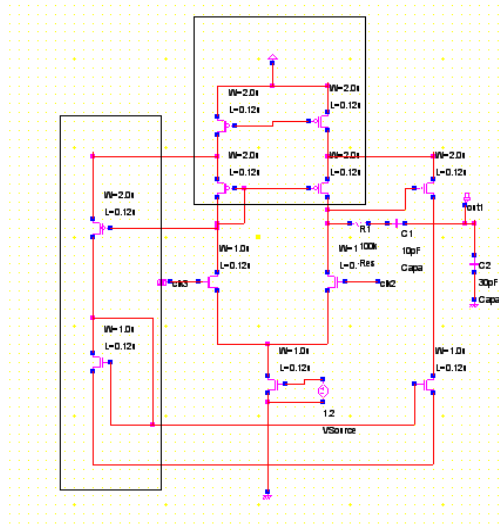

Fig 4(a).Schematic of class AB two stage op-amps with current replicating branch using adoptive loadII

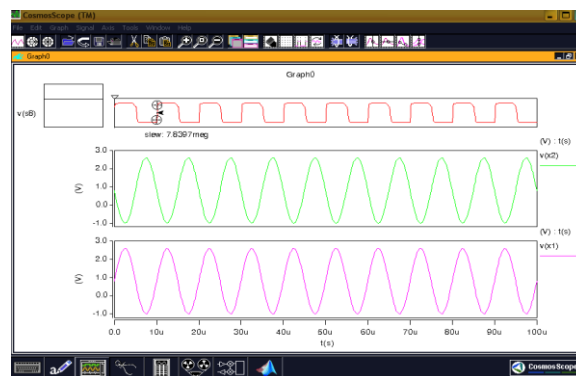

Fig 4(b).Output waveform of class AB two stage p-amps with current replicating branch using adoptive load II.

Organized by

Dept. of ECE, Annamacharya Institute Of Technology & Sciences, Rajampet, Andhra Pradesh-516126, India held on 28th February 2015

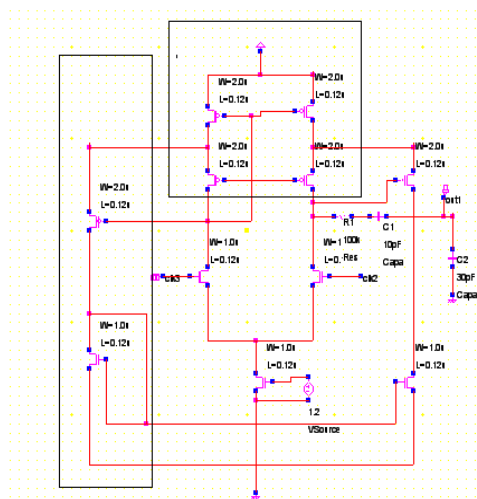
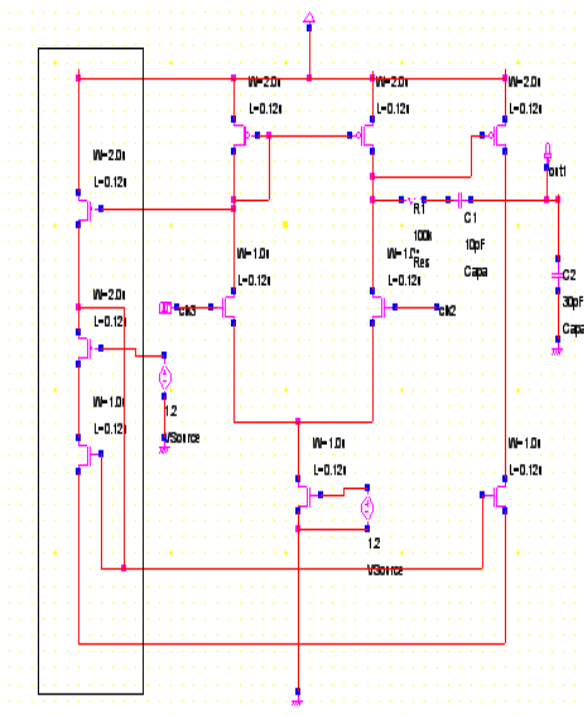

Fig 5(a).Schematic of Class AB two stage op-amp with current replicating branch using adaptive load I at the input stage.



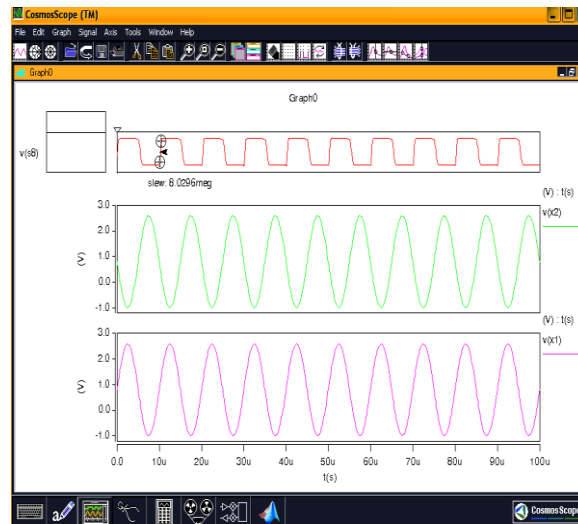

Fig 6(a).Output waveform of Class AB two stage op-amp with current replicating branch using adaptive load I at the input stage.

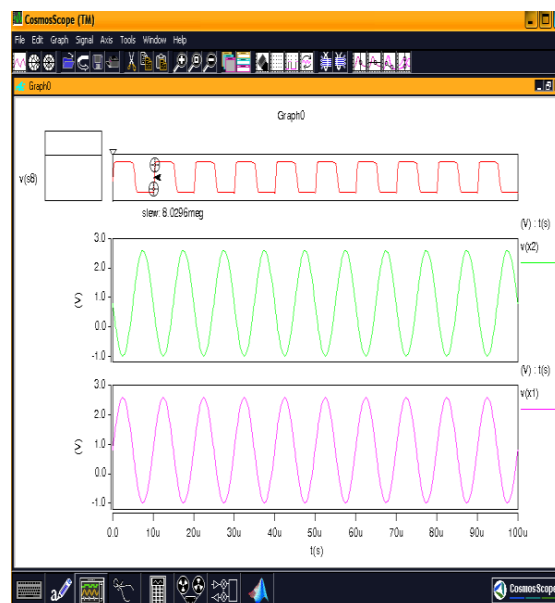

Fig 5(b).Schematic of class AB two-stage op-amp with current replicating branch using an adaptive load.

Fig 6(b).Output waveform of class AB two-stage op-amp with current replicating branch using an adaptive load

IV.COMPARISION TABLE

CIRCUIT NAME	SLEW RATE (V/ μ S)	POWER (MW)
(a) Conventional two stage op-amp	2.1389Meg	2.761
(b)Free class ab op amp	3.2387 Meg	1.8597
(c) Push pull op-amp withcurrent replicationbranch	4.2628 Meg	2.2329
(d) Class ab two stage opampwith current replication branch andadoptive loads	7.8397 Meg	2.2818
(e) ClassAB two stage op-amp with current replication branch using adoptive load I at the input stage	8.0296 Meg	6.3124
(f) Proposed	8.0296 Meg	1.1636

COMPARISION GRAPH

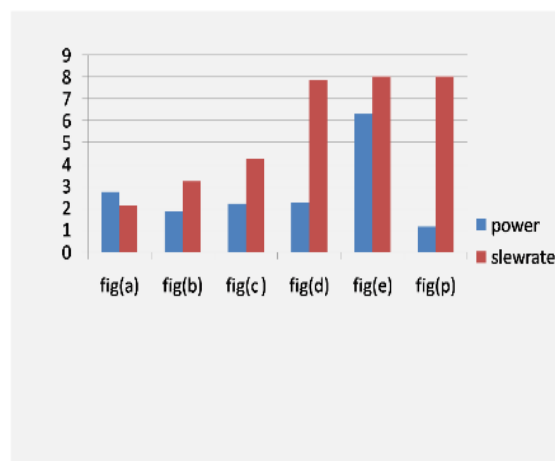



V.ACKNOWLEDGMENT

The authors gratefully acknowledge the constructive comments by the reviewers.

VI. CONCLUSION

The different schemes of power-efficient class AB two-stage op-amps are introduced by using a current replication branch and adoptive loads have been experimentally tested. They achieve approximately symmetrical and high slew rate with very small additional static power dissipation and small additional circuitry.

REFERENCES

- [1] A.J. López-Martín, A. J., Baswa, S., Ramirez-Angulo, J., & Carvajal, R. G. (2005). Low-voltage super class AB CMOS OTA cells with very high slew rate and power efficiency. *Solid-State Circuits, IEEE Journal of*, 40(5), 1068-1077.May 2005.
- [2] Galan, J. A., Lopez-Martin, A. J., Carvajal, R. G., Ramirez-Angulo, J., & Rubia-Marcos, C. (2007). Super class-AB OTAs with adaptive biasing and dynamic output current scaling. *Circuits and Systems I: Regular Papers, IEEE Transactions on*, 54(3), 449-457.Mar.2007
- [3] Ramirez-Angulo, J., & Holmes, M. (2002). Simple technique using local CMFB to enhance slew rate and bandwidth of one-stage CMOS op-amps. *Electronics Letters*, 38(23), 1409-1411.Nov.2002.

BIOGRAPHY



Mrs.Vijaya Nirmala was born in kadapa, Andhrapradesh india .she received master degree in DSCE design from JNTU Anantapur in the year2008.She received B.tech degree in electronics and communication engineering from Bharathi dasan university in the year 2003.



Mr.Eswar Narayana was born in kadapa, Andhra Pradesh, India in 1990.He is persuing master degree in VLSI design from JNTU Anantapur.He received B.tech degree in electronics and communication. Engineering from JNTU Anantapur in the year 2012.His interested areas are research of VLSI design, CAD for VLSI and testing for VLSI.