



Automated Toll e-Ticketing Using Msp430launch Pad

B.Venkata Ramana, G.Thirumalaiah

P.G Scholar, (M.Tech), Department of Electronics and Communication Engineering, Annamacharya Institute of Technology and Sciences, Rajampet, Andhra Pradesh, India

Assistant Professor, Department of Electronics and Communication Engineering, Annamacharya Institute of Technology and Sciences, Rajampet, Andhra Pradesh, India

ABSTRACT: In nowadays almost all highways toll plazas are manually operated, where an operator collects cash from the driver and provides a receipt. Since this procedure can be slow, we often encounter traffic jams at the toll plazas on busy highways. Automatic process of toll collection will save time, effort, and man power. We propose a low cost and efficient technique called Electronic Toll Collection using RFID modules that automatically collects the toll from moving vehicles when they cross the toll plaza. We also assume that an owner maintains a prepaid account, so that toll tax is deducted automatically from the driver's account at toll plaza. If the balance in the owner's account is low or if the vehicle is not equipped with an RF system, the toll gate remains close. In such a case vehicle owner will have to pay the toll tax in cash and collect the receipt. The owner receives an SMS message on his/she mobile about the details of the payment and there is no need for him to stop the vehicle. How many vehicles passing through the toll gate stored in a database. We can also find out a vehicle how many times passing through the toll gate in a day. Through this process of toll collection will save time, effort and man power.

KEYWORDS: Radio Frequency Identification (RFID), RF Modules, Toll Plaza, Electronic Toll, RFID Tags, Traffic Jams.

I. INTRODUCTION

Figure 1 explains the automatic toll e-ticketing system. As the vehicle approaches the toll plaza, it is detected using Infrared Proximity Sensor. An RFID tags to reads the RFID reader. An IR receiver present in then receives these pulses and sends it to a controller (MSP 430 Launch pad), which than transmits the vehicle number through the RF transmitter located in vehicle.

We assume that vehicles have 16-bit identification numbers. The RFID tags to readers read the signal and information about vehicles owners. These RF signals are received by an RF receiver at the toll plaza, which send data to a computer's parallel port. A software program running on the computer retrieves vehicle details from its vehicle database. Depending on this information, appropriate toll tax is deducted from the pre-paid account of the vehicle's owners. The owner receives an SMS message on his/her mobile about the details of the payment. If the balance in the owner's account is low or if the vehicle is not equipped with an RF system, the toll gate remains close. Next method proposes a very simple method for enhancing the performance of infrared electronic-toll-collection systems, in such a case, the vehicle owner will have to pay the toll tax in case and collect the receipt, Figure2 explains the concept in the form of a block diagram.

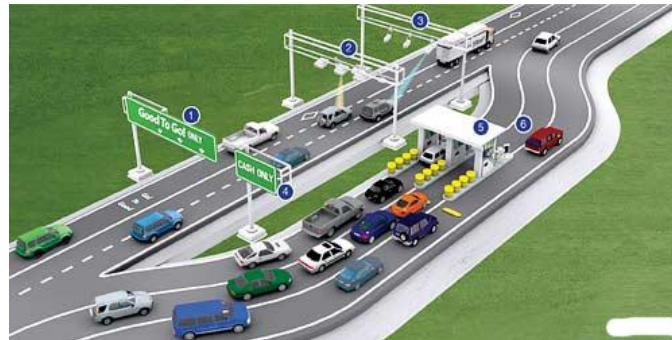

Figure 1: Working of the E-Toll collection System

We need a system for handling violation and acknowledgement when a vehicle does not have an RFID module installed, a vehicle's ID number is not found in the database, or a driver has insufficient funds to pay toll. If an acknowledgement is not received in a predefined time from the database, the toll plaza gate remains closed. Existing automatic toll collection techniques incur power loss since the receiver is continuously turned on, even when no vehicle arrived at a toll plaza. In our technique, only the IR sensor is turned on to detect the arrival of vehicles. Only when a vehicle is detected, RFID Tag to RFID reader reads the data.

II.HARDWARE DESCRIPTION OF AUTOMATED TOLL E-TICKETING SYSTEM

A.PROGRAMMING BOARD:

We designed a programming board to program the MSP430 Launch pad microcontroller. This consists of JTAG in Spy-Bi-Wire mode. The power supply was connected with fuse blow protection. Additionally, the port pins were attached with a single pole single throw (SPST) switch and LED for testing the code visually.

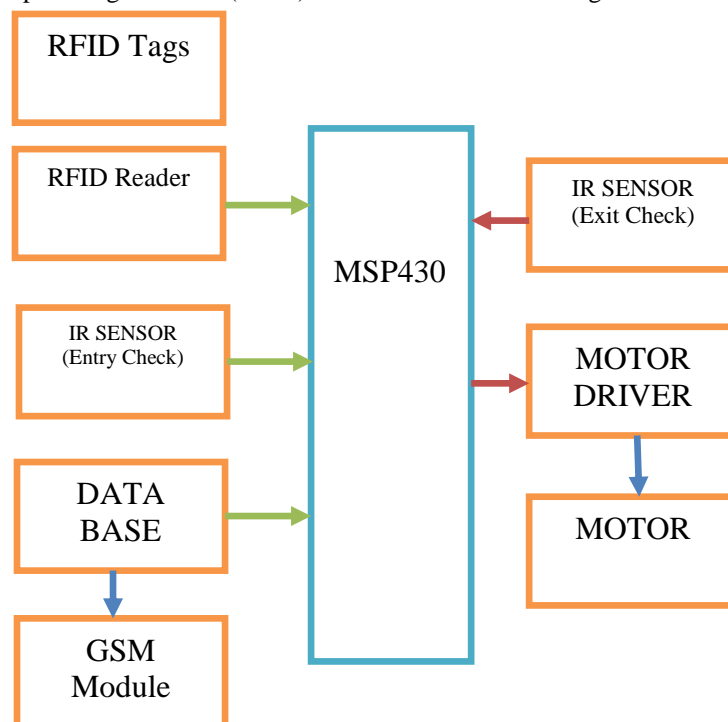
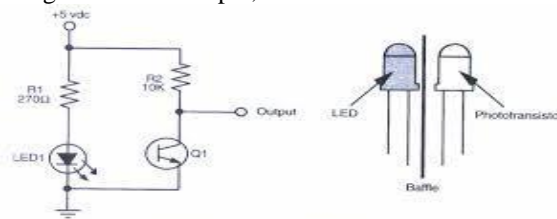

Fig2: Block diagram of automated toll-ticketing

B.IR PROXIMITY SENSOR:

An IR transmitter/LED is a device that emits infrared light outside the visible spectrum. It emits the light near-infrared energy at about 880nm. The device that detects or receives the IR light is called infrared sensor which sense aspects of its surroundings to show fig 3. In our example, the IR sensor is used to detect arriving vehicles.

**Figure 3 : IR Proximity Sensor**

The SE555P Timer by Texas Instruments is used in the monostable mode. When IR radiation is received (“no vehicle ” condition) triggering occurs, resulting in a high output. When a vehicle arrives at a toll plaza,the IR ray are blocked by the vehicle,and the output of the timer to toggle to low. The change in output of the timer is sensed by the microcontroller,which is programmed to turn on the IR transmitter. The IR sensor at the entry and exit check is used to make the controller wait until it receives the acknowledgement signal and to block the vehicle when automatic transaction failed.

C.RADIO-FREQUENCY IDENTIFICATION (RFID):

Radio-frequency identification (RFID) is a technology that uses radio waves to transfer data from an electronic tag, called RFID tag or label, attached to an object, through a reader for the purpose of identifying and tracking the object. Some RFID tags can be read from several meters away and beyond the line of sight of the reader. The application of bulk reading enables an almost-parallel reading of tags.

RFID TAGS:

RFID tags can be either passive, active or battery assisted passive. Passive RFID does not use a battery, while an active has an on-board battery that always broadcasts or beacons its signal. A battery assisted passive (BAP) has a small battery on board that is activated when in the presence of a RFID reader. Most RFID tags contain at least two parts: one is an integrated circuit for storing and processing information, modulating and demodulating a radio-frequency (RF) signal, and other specialized functions; the other is an antenna for receiving and transmitting the signal.

D.DATA TRANSMISSION:

The vehicle code is transmitted through RFID communication between the vehicle and toll plaza. An RFID1800 module, in combination with a modem, is used to transmit and receives electromagnetic signals. We used is the EM000 family RFID module in our project. It has ability to transmit and receive data with a 4cm range. In addition to the 4-digit vehicle number, three additional nibbles are transmitted –two at the start and one at the end of the vehicle number. The frequency of operation of the RFID Reader module is in UHF band from 125 kHz to 928MHz, operating at 5V supply. They are referred to as passive tags because the only time at which they are actively communicating is when they are within relatively close proximity of a passive RFID tag reader or interrogator. This on board power source allows an active RFID tag to transmit information about itself at great range, either by constantly becoming this information to a RFID tag reader or by transmitting only when it is prompted to do so.

International Journal of Innovative Research in Computer and Communication Engineering

An ISO 3297: 2007 Certified Organization

Vol.3, Special Issue 4, April 2015

National Conference On Emerging Trends in Information, Digital & Embedded Systems (NC'e-TIDES -15)

Organized by

Dept. of ECE, Annamacharya Institute Of Technology & Sciences, Rajampet, Andhra Pradesh-516126, India held on 28th February 2015

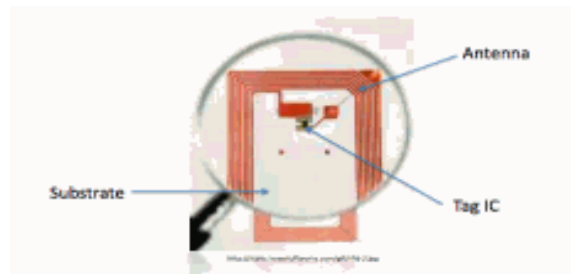

Fig: RFID Tag

The transmit enable triggered low by the controller to handle transmission of data by RFID module. The code for handling the RFID module is developed for the MSP430G2453 microcontroller using assembly language. Initially, the watchdog timer of the microcontroller is turned off and the directions of the ports are set and all the outputs are initialized. When an input is received, the RFID reader is done by making the transition and detected. A delay function is used with two different delay values – a higher delay is used between “end of one transmission” and the “start of transmission”. A smaller delay used between “start of transmission”. This is to avoid the transmission of the same data more than once. The RFID module at the toll plaza is configured with some reading capability. The reads also operated at 928MHz, and has a sensitivity of 3V.



Figure 5: RFID Reader

E.TOLL GATE OPERATION:

The toll gate need to be operated fast to increase the traffic throughput. In our demonstration version, we used the motor present in the Compact Disk (CD) players as they operate at very small voltages (~3V) as shown in figure 6. The motor used is connected with gear to reduce the speed of the motor and to open and close the gate attached to them. Once the negative acknowledgement signal from the computer is received by the microcontroller or the microcontroller is timed out then it gives a pulse to the gate which makes the gate close. A manual switch is used to open the gate circuit are given using the Relay Mate Cables (RMC) as the gate is a separate structure.

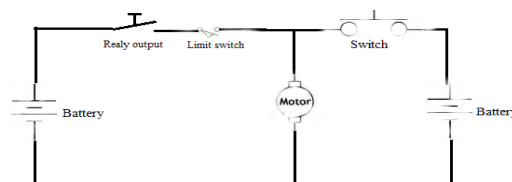
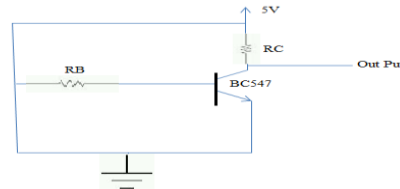

Figure 6: Gate Operation Circuit

F.SWITCHING INPUT TO MICROCONTROLLER:

As the microcontroller needs only 3.3V to operate, the board was designed for 5V operation. The inputs to the microcontroller were given through a transistor switch as shown in figure 7.

**Figure 7: Transistor as a switch**

III.SOFTWARE IMPLEMENTATION

A.MICROSOFT ACCESS:

For secure and easy access of the database, we used Microsoft Access which is relational database management system from Microsoft Corporation. Microsoft access is supported by Visual Basic for Applications, an object-based programming language that can reference a variety of objects including DAO (Data Access Object).

B.VISUAL BASIC:

Visual Basic 6.0 was used to interface the microcontroller with the personal computer in the e-toll plaza. The inputs from the microcontroller are given to the PC's parallel port and this Data is retrieved by VB 6.0 software program, which manages the database. On receiving the input from the MSP430G2553 microcontroller, the program deducts the toll amount from account balance, returns success or failure acknowledgement to the controller and runs an executable file to send the transaction statement as SMS to the owner's mobile number from the database. See figure8 which show the GUI.

C.SENDING SMS:

We made use of SMS send, Message to be sent are register in "SEND_SMS". The transmission is activated by setting the START_SMS parameter once an open source software which helps connect the mobile phone as a GSM modem to the computer via a data cable. The software uses the SIM card in the mobile phone to send the SMS. The mobile is connected to the computer via COM. The operations of the software are automated using a *Message Loop (default)*. It is wise to call this function many times per second in a loop; otherwise, you will have a slow or unresponsive GUI. COM extensions provide a common interface for working with software applications in a Microsoft environment. Applications have defined COM objects that can be used in AutoIt (and other programming languages) to manipulate the applications and perform tasks within them. To use COM objects, you must know the object name and its properties and methods.

D.IAR Workbench:

IAR Workbench Kick start version provided by Texas Instruments was used to develop the microcontroller programs as it was user friendly and has both simulation and debugger mode. This also makes the process of loading the programs to the controller faster and easier.

IV.RESULTS

We developed a working prototype of the project and tested it in a "simulation environment" with toy car. A video of the project demonstration can be viewed at See figure 9 for a picture of testing environment. We tested it in several use cases. The advantage of using RF over RFID is that the range of the former is much greater than that of the latter, and there is no need to stop the vehicle. Another innovation is that the usage of IR system to switch on the RFID vehicle instead of the infrared sensors. So the range of the IR sensor is high that the reception of signal in a wider range. The choice of using the parallel port for the communication is another innovation that makes the communication of the microcontroller and computer speedy. The electronic toll collection increases user convenience and eases traffic congestion. The user need not carry exact cash. The low maintenance cost of the system can also help reduce the toll free.

The security at the toll booth will improve in this system and it will become possible to detect stolen vehicles. Since cars do not have to stop at the toll booth, savings on fuel from repeated stops for vehicles, and reduction in accidents. There are several limitations of the proposed system. It requires a user to have a dedicated prepaid account.

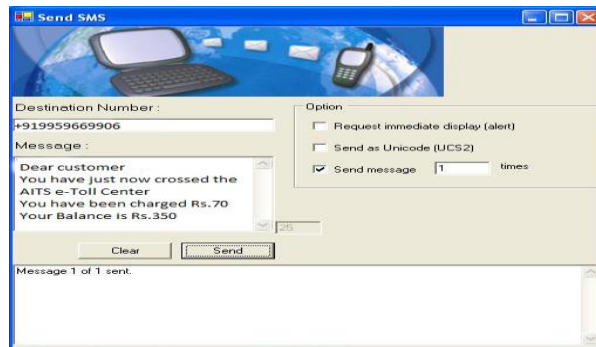

(a) Graphical User Interface for the Toll Plaza Software

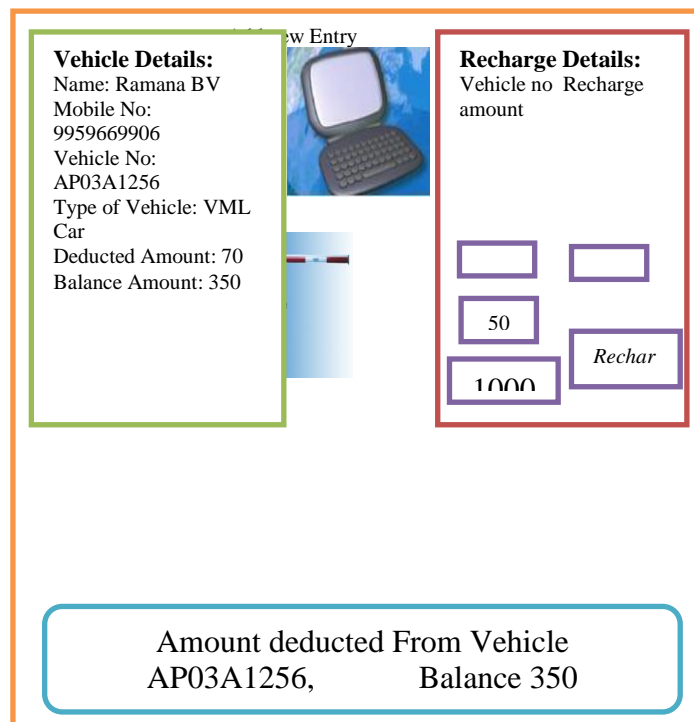

(b) Graphical User Interface for sending SMS acknowledgement
Figure 8: Graphical User interface for the Toll Plaza

Since the infrared proximity sensor is used in detecting the arrival of vehicles, there can be interface from external source of light. Since highways are operated in two directions, If computer of the toll plaza are connected in a network, then a vehicle from one state can use the automated facility of a toll booth in another state. The unique identification number of vehicle can be increased to larger number. Vehicle theft can be prevented by anti-theft alarm along with this kit.

International Journal of Innovative Research in Computer and Communication Engineering

An ISO 3297: 2007 Certified Organization

Vol.3, Special Issue 4, April 2015

National Conference On Emerging Trends in Information, Digital & Embedded Systems (NC'e-TIDES -15)

Organized by

Dept. of ECE, Annamacharya Institute Of Technology & Sciences, Rajampet, Andhra Pradesh-516126, India held on 28th February 2015

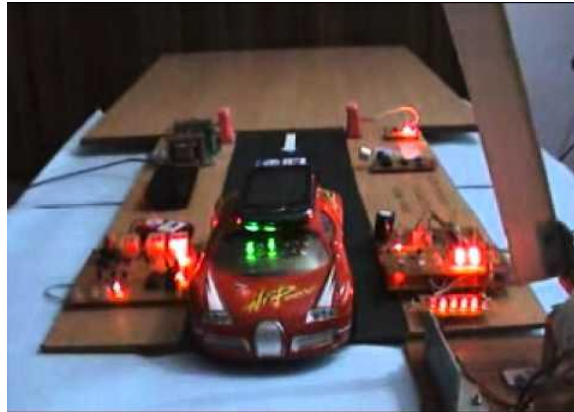

Test environment for our project-Vehicle at the Toll Plaza

V.CONCLUSION AND FUTURE WORK

In this Paper, the concept of Automated toll e-ticketing using MSP430 Launch pad. We have used an innovative approach where a traveller will be able to pay the toll while in motion using RFID communication technology. Through this process of toll collection will save time, effort, and man power. How many vehicles passing through the toll gate stored in a database. We can also find out a vehicle how many times passing through the toll gate in a day. The improvement can be done to develop a multi vehicle amount deducted and send a SMS at a time multi vehicle.

REFERENCES

1. James J. Barbelllo. Handbook for parallel port design. Prompt Publications, 1999.
2. Andy Flessner. Autolt v3: Your Quick Guide. O'Reilly Media, 2007.
3. Ranjan D. "Howto send and Receive SMS using GSM Modem." Internet: <http://www.codeproject.com/KB/cs/SMS.aspx>
4. "Hardware Interfacing and TCP/IP interfacing in VB programming." Internet: http://www.thaiio.com/prog-cgi/0006_vb.html
5. COM. http://download.microsoft.com/download/win2000platform/overview/1.00.0.1/nt5/en-us/oleview_setup.exe.
6. W.-H. Lee, B.-S. Jeng, S.-S. Tseng, and C.-H. Wang, Electronic toll collection based on vehicle-positioning system techniques, in Proc. IEEE Int. Conf. Networking, Sensing, and Control, Taipei, Taiwan, R.O.C., Mar. 21–23, 2004, pp. 643–648.
7. <http://www.ti.com/tool/msp-exp430g2>.
8. C.M. Roberts, "Radio Frequency Identification (RFID)," *Computers & Security, Elsevier*, 2006.
9. W.-H. Lee, B.-S. Jeng, S.-S. Tseng, and C.-H. Wang, —Electronic toll collection based on vehicle-positioning system techniques, in Proc. IEEE Int. Conf. Networking, Sensing, and Control, Taipei, Taiwan, R.O.C., Mar. 21–23, 2004, pp. 643–648.

BIOGRAPHY



B. Venkata Ramana received B. Tech Degree from J.N.T University, Anantapur. He is currently working towards M. Tech in Electronics & Communication Engineering from J.N.T University, Anantapur, India. His research interests include embedded systems.



G. Thirumalaiah received B. Tech and M. Tech Degree in electronics and Communication Engineering from J.N.T University, Anantapur, India. Presently he is with Annamacharya Institute of Technology and Sciences, Rajampet, A.P, India working as an Assistant Professor in Department of ECE. His research interests include embedded systems, Signal Processing and digital Imaging. He presented many research papers in national, international conferences & Journals.